

PRODUCT CATALOGUE

CONNECTING
ENERGY

MEMBER OF **FPD**



CONTENS

About our company SEZ DK a.s.	4 - 5		
Industrial sockets and plugs	6 - 13	Terminal blocks, strips and terminal boards	122 - 125
Cable plugs	14 - 19	Terminal blocks	126 - 128
Cable sockets	20 - 25	Ending clamp	128
Wall sockets	24 - 33	DIN rails	129
Wall inlets	34 - 39	Terminal strips	129
Panel sockets – angled	38 - 43	Instrument terminal strips	130
Panel sockets – straight	42 - 45	Ceramic couplings and ceramic terminal blocks	130 - 131
House sockets	44 - 47	Terminal boards for rising mains	131 - 133
Panel inlets – angled	46 - 47	Equipotential terminal blocks	133
Panel inlets – angled	48 - 49		
Panel inlets – straight	48 - 53	Installation boxes, cable glands	136 - 139
Adapters	52 - 55	and terminal blocks	
Cable adapters	56 - 57	On wall boxes with terminal rings	140 - 141
Switched interlocked sockets	58 - 61	Under the plaster boxes	141 - 142
Protection caps and parts	62 - 63	Hollow walls boxes	143 - 144
		Hollow walls boxes, terminal rings	144
Distribution boxes	66 - 71	On wall boxes	145 - 146
8, 4 and 0-modules distribution boxes	72 - 79	Junction box with proven functionality in fire	147
ROS Mini - IP44		Surface boxes for trunkings	148
Distribution boxes Micro RO SP - IP54,	80 - 83	On wall boxes IP65	149
ROSPG - IP67		Junction and lightning protection boxes	150
Distribution boxes Micro with switch – IP44	84	Cable glands Pg, Metric and fixing nuts	151 - 153
Compact distribution boxes with straight	85 - 86	Cable connectors	154
inlet ROP - IP44		Mounting accessories	155 - 157
Hang-on distribution boxes ROK IP54	87		
4-modules distribution boxes ROS 4- IP44	88	Terminal components	160 - 163
Distribution boxes with switch ROS 4/V-IP44	89	Cable lugs - tubular	164
6-modules distribution boxes ROS 6 - IP54,	90 - 95	Cable lugs, crimping pliers, cable connectors	165
ROS M6 - IP54/IP65		Cable lugs - crimping	166
7-modules distribution boxes with switch	96 - 98	Bolt-on cable lugs, cupal washers, terminal pins	167
ROS 7 - IP54		Insulated cable connectors, flat female, male	168
11-modules distribution boxes ROS 11 - IP54	99 - 106	Insulated flat male, female and fork terminals	169
16-modules distribution boxes ROS 11 - IP54/	107 - 109	Insulated cable lugs and cable sleeves	170
IP66		Insulated cable sleeves and pin terminals	171
Building distribution boxes 11, 12, 16	110 - 115	Multipole flat male and female terminals and insulator	172
and 24 modules- IP 44, IP54, IP65, IP66		Bolt-on flat male and double male terminals	173
Semi-assemblies and spare parts	116 - 119	Multipole flat male and female terminals,	174
		multipole palstic sockets and plugs	
		Multipole plastic sockets and plugs combined	175
		Register	176 - 182



SEZ DK a. s.

Our company SEZ DK a.s. was founded in 1947 as one of the first plants given in the field of industrialization. Thanks to a long tradition, experience and state-of-the-art technology in the field of electrical installation production, we have long maintained our position as a leader in the countries of Central Europe.



MARKET LEADER

Among the countries of Central Europe, we have maintained our position as a market leader in the production of electrical installation materials.

MEMBER OF FPD GROUP

We have been a member of the FPD Group since 2009. The investors' priority was the renewal of the technology park and the introduction of a modern management system.

PRODUCTION FACILITIES

Our production facilities cover an area of 50 569 m². Within our production capacities, we cooperate with verified, renowned brands.

SERVICES

We use our own development to develop products.

Our R&D department and tool shop ensure the construction and production of press moulds and mechanical tools. Our portfolio also includes a press, galvanization plant, metal production and assembly.

ISO CERTIFICATION

We were awarded organisational management system certification according to ISO 9001, EN ISO 9001: 2015.

EXPORT

We supply products that bear our brand to more than 25 countries around the world. Our export activities comprise up to 70 % of our total production.





INDUSTRIAL SOCKETS AND PLUGS

CONTENTS

Industrial sockets and plugs	6 - 13
Cable plugs	14 - 19
Cable sockets	20 - 25
Wall sockets	24 - 33
Wall inlets	34 - 39
Panel sockets – angled	38 - 43
Panel sockets – straight	42 - 45
House sockets	44 - 47
Panel inlets – angled	46 - 47
Panel inlets – angled	48 - 49
Panel inlets – straight	48 - 53
Adapters	52 - 55
Cable adapters	56 - 57
Switched interlocked sockets	58 - 61
Protection caps and parts	62 - 63



INDUSTRIAL SOCKETS AND PLUGS

Our industrial plugs and sockets have been designed to connect electrical devices and consumers to low voltage in a broad spectrum of human activities. They are frequently applied in civil engineering, electric assembly sector, engineering industry and other sectors of the economy.

TECHNICAL PARAMETERS:

- nominal current: 16 A, 32 A, 63 A, 125 A,
- nominal voltage: 110 V, 230 V, 400 V, 500 V,
 - nominal frequency: 50 Hz and 60 Hz,
- degree of protection: IP 44, IP 54, IP 67,
 - number of poles: 3P (2P+PE),
 - 4P (3P+PE),
 - 5P (3P+N+PE),
- operating temperature: -25 °C to +55 °C.

Our sockets, plugs and connectors are manufactured under the STN EN 60309 – 1, 2, 4 norms which comply with European norms EN 60309 – 1, 2, 4 and international recommendation IEC 60309 – 1, 2, 4.

QUALITY FIRST

The construction of our devices respects the demands on their strong reliability and durability as well as the requirements of health protection. In a short preview we summarise the fundamental security principles, which will be appreciated by all users of our industrial sockets and plugs.

INSULATION RESISTANCE AND DIELECTRIC STRENGTH OF THE DEVICES MUST BE SUFFICIENT

Tests are carried out to check the fulfilment of these requirements which immediately follow after the tests in the humidity chamber or room where the testing samples have been adjusted to prescribed temperature. Insulation resistance is measured by the voltage of approximately 500 V; the measuring begins one minute after the voltage has been applied. The insulation resistance must not be lower than 5 MOhm. Dielectric strength is measured by the 50 Hz/60 Hz frequency sinusoid voltage of 2 000 V (2 500 V respectively, for the devices with the nominal voltage of 500 V), which is applied for 1 minute. Neither flash-over nor breakdown must appear during the test.

NON-BLOCKED DEVICES MUST HAVE ADEQUATE DISCONNECTING CAPACITY

A plug or a mobile socket is inserted into a built-in (wall) socket or a connecting built-in appliance, inlet (wall inlet) and subsequently pulled out with the frequency of 7,5 strokes per minute. The electric contact is maintained for not longer than 4 seconds and not shorter than 2 seconds. There are 50 cycles set for the 16 A and 32 A devices, 20 cycles for 63 A and 125 A devices, respectively. The samples are tested at the 1,1 level of Surface treatment contacts; and 1,25 level of nominal current values and line current factor 0,6. A persistent arc must not appear during testing. When tested, the samples must not show any damage that would disable their further operation and plug pin inlets must not show any serious damage either. Our 63 A and 125 A sockets and plugs maintain sufficient switching capacity, their electrical blocking by a control (pilot) contact is therefore unnecessary.

NORMAL OPERATION

The devices must be resistant to the effects of mechanical, electric and heat stress which may appear during normal operation without any excessive wear or other damaging effects. The non-blocked devices tested as described in Point 2 above are further tested in the following cycles:

- devices 16 A – 5000 cycles under load only.
- devices 32 A and 63 A – 1000 cycles under load, 1000 cycles unloaded.
- devices 125 A – 250 cycles under load, 250 cycles unloaded.
- loading condition: load of nominal voltage and nominal current under line current factor 0,6.

After test the samples must not show:

- any wear preventing further operation of the device and its possible blocking, respectively.
- any damage of cover or barriers.
- any damage of plug pin inlets which could cause malfunction.
- any loosening of electric or mechanical connections.

WARNING – Disconnecting capacity is required as protection in case of accidental insertion or release of a plug under load. According to STN 33 2180, industrial sockets and plugs are not designed for the operational switching on and off of electrical appliances.

MECHANICAL RESISTANCE

Dismantling devices are equipped with the lightest type of power supply cable of the smallest suitable cross-section. They are then frozen at the temperature of -25 °C. Subsequently, the free end of the 2,25 metre-long cable is attached to the wall at 75 cm over the ground. The sample is held so that the cable remains in horizontal position and then is dropped onto the concrete floor. The process is repeated eight times, while the cable is twisted of 45° in the point of attachment before each trial. After tests the samples must not show any damage, chiefly, none of the parts may be loosened or separated.

HEAT AND COMBUSTION RESISTANCE

Parts made of insulation material are tested by static burden by an appropriate testing device. The surface of tested parts is placed in horizontal position and a steel ball with 5 mm diameter is pressed into that surface with the force of 20 N.

Testing takes place in a heat chamber at the temperatures of:

- 125 °C for parts which carry the live parts of dismantling device.
- 80 °C for other parts.

The ball is removed after one hour and the diameter of the impression is measured. If the material has been deformed, the diameter must not exceed 2 mm.

The external parts of insulation material and insulation parts that carry the live parts of device must be resistant to excessive heat and combustion. The hot wire test, described in IEC 60695-2-1, is used to check if this requirement is fulfilled.

The temperature of hot wire is:

- 650 °C for insulation material parts not needed to keep the conducting parts and protection circuit parts in their position even though they touch them.,
- 850 °C for insulation material parts needed to keep the conducting parts and protection circuit parts in their position.

The contact lasts 30 seconds.





A device passed the hot wire test, if:

- neither perceivable flame nor permanent heating had appeared or the flame or the heating of the sample or its surroundings ceased within 30 seconds after the hot wire had been removed and the surrounding parts did not burn completely.

THE RESISTANCE OF RUBBER AND THERMOPLASTIC TO AGEING

The devices with rubber or thermoplastic covers and elastomeric parts, such as joint rings and washers, must show sufficient resistance to ageing which is checked by accelerated ageing test in the atmosphere with normal air composition and pressure. The samples hung freely in a heat chamber with the natural circulation of air.

The chamber temperature and test duration are as follows:

- 70 °C and 10 days for rubber.
- 80 °C and 7 days for thermoplastic.

The samples are examined after the chamber has been cooled to standard room temperature. No cracks may be visible to the naked eye and the surface must not be sticky or greasy. The samples must not show any damage which would lead to the failure of standard requirements.

The design of the devices ensures that the devices with different working voltages are not interchangeable. The working voltage of a device is determined by the position of the key groove and the protective contact, the so-called hour angle, when the key groove is always in the position of 6 hours. The figure of the hour angle is derived from the position of the protective contact compared to the clock face, the socket being observed from the front. To prevent fault connection, the socket is fitted with a key groove, while the plug is fitted with a key. The diameter of protective pin is different from that of phase pin, wrong insertion is therefore completely excluded.

THE INSTALLATION OF SOCKETS AND CONNECTORS ON FLAMMABLE SURFACES

To meet the requirements of STN 33 2312, sockets and inlets cannot be installed directly on flammable or easily combustible surfaces. It is necessary to separate them from such surfaces by a non-flammable, heat-insulating plate at least 5 mm thick, protruding at least 10 mm on each side, or they must be installed in at least 30 mm distance from the flammable surface, e.g. on consoles in accordance with STN 33 2312.

Dimensioning of connecting terminals

Socket system IEC (A)	Motor output (kW)		Connecting terminals for conductor (mm ²)	
	400 V	500 V	mobile wiring flexible conductor	fixed wiring rigid conductor
16	7	9	1 - 2,5 Cu	1 - 4 Cu/Al
32	15	20	2,5 - 6 Cu	2,5 - 10 Cu/Al
63	30	40	4 - 16 Cu	6 - 25 Cu/Al
125	60	80	16 - 50 Cu	16 - 70 Cu/Al

kW data are approximate

In 63 A devices we have widened the assortment by the 5-pole appliances in protection IP 67 whose shape is adjusted to 16 A and 32 A series. They are distinguished from the IP 44 versions by the letter G., i.e. cable sockets ISGN, cable plugs IVGN, wall sockets IZGN, wall inlets IPGN, panel sockets IEGN, panel inlets IRGN and panel inlets straight IRRGN. The authentic technical solutions of the connecting terminals and the cable fixing and its sealing have been used also in these sockets and plugs.

REVERSING ADAPTERS, ADAPTERS

Reversing adapters "RA" 32 A and 16 A providing the change of the phase sequence and the adapter "A" from 5-pole socket into a 4-pole socket have been added to the range of goods of our production. Its use is allowed on the symmetric load since the 4-pole socket has the 3P + PE type of connection.

PANEL SOCKETS, PANEL INLETS ANGLED, STRAIGHT, REVERSE

All appliances in this product group 16 A and 32 A, in versions 3P, 4P, 5P, 6h are exceptional in that they use a uniform mounting base with external dimensions of 75x75 mm for mounting on the panel as well as a common spacing of mounting holes 60 x 60 mm which simplifies and unifies their assembly and interchangeability. The terminal parts are identical to other sockets and plugs.

WALL SOCKETS WITH BOX UNDER PLASTER

The IZV socket will find its scope and use in the tidy-looking interiors above all, where the emphasis is put on the accurate implementation and a decent presence of industrial sockets. The box embedded in the plaster is common for all of the types. 6 openings for conductor inputs are situated on the box – 4 of them of oval shape on the side walls and 2 of round shape on the bottom of the box. The boxes can be connected in a row of any length by the connecting element PR-10 interacting with special protrusions on the boxes.

WALL SOCKETS-COMBINED

Our new product of a type designation IZVZ combines 400 V and 230 V socket in one product. It finds its use in all the cases when the situation calls for a simultaneous connection of a single-phase and three-phase device. A special emphasis was put on the electric capability, safety and user-friendliness in course of the development of the device. IZVZ is supplied on the market in the cover of IP 44 and in versions 16 A 4P (IZVZ 1643), 16 A 5P (IZVZ 1653). The 32-ampere variants (IZVZ 3243, IZVZ 3253) are delivered with a case for a tube fuse 16 A for single phase 230 V/16 A socket safety.

INDUSTRIAL PLUGS AND SOCKETS 125 A

In 2008 we added into our range of products the following products: industrial plugs, inlets and sockets of current 125 A in 3, 4, 5 poles with voltage 110 V, 230 V, 400 V and 500 V in protection IP 67.

NEW SERIES OF 16A/230 V, 3P INDUSTRIAL PLUGS, SOCKETS AND INLETS

Our production portfolio has been completed by the newly developed industrial plugs and sockets under Types IVN, ISN, IZN, IPN, IRRN, IERN with the nominal current of 16 A, 3 P, 230 V.

SCREWLESS SERIES

Company SEZ DK expanded its assortment in new screwless range 16 A and 32 A – 5-poles industrial sockets and plugs IVB, ISB, IZB, IPB, IEB, IERB, IRRB (letter B means screwless).

Generally, the system of screwless terminal can be solved in many ways and our system uses the principle of a spring terminal, featuring a screwless spring clamp which allows to connect rigid conductors up to cross section 4 mm² in 16 A appliances and flexible wires up to 2,5 mm². In 32 A the cross section are 10 mm² for rigid and 6 mm² for flexible wires respectively. Connection of male or female pin with holder of spring clamp is realized by a special orbital riveting. Successful implementation of this technical principle we achieved firm and fast connection with no further need of continuous control of connection quality and safety during its use.

New technical solution markedly shortens time of montage in 39 % in compare with screw sockets and plugs. Reduction of this time is achieved that covers of plugs and sockets are in transport unlocked position (opening without using of screwdriver) and also plugs, inlets and sockets contacts are delivered in open position (operating levers are detached) and after putting of stripped wire (rated length is 12 mm) you just to push the operating

levers down and the wire is fastened. Particular operating levers are distinguished by respective colours and together with the indicative marking on the plastic body the chance of a wrong connection of individual wires is minimalized.

PILOT CONTACTS

Plugs and sockets with nominal current 125 A are offered also with pilot contacts. They are placed in the middle of socket and they interrupt input by the contactor from the network during pulling the plug out. Contacts are disconnected without current and there is no burning on them.

DEGREE OF PROTECTION IP

Stated in the catalogue our plugs and sockets with the nominal current 16 A, 32 A, 63 A meet the degree of protection of IP 44, IP 54 or IP 67 and 63 A, 125 A reach IP 67 in compliance with STN EN 60529.

The degree of protection is tested:

- on the sockets themselves and also in their coupled position.
- on plugs and inlets after their full coupling with the corresponding sockets.

IP xx

Protection against solid bodies

Protection against water

First digit	Protection against solid bodies	Second digit	protection against water
0	non protected	0	non protected
1	protected against solid foreign objects of 50 mm \varnothing and greater	1	protected against vertically falling water drops
2	protected against solid foreign objects of 12,5 mm \varnothing and greater	2	protected against vertically falling water drops when enclosure tilted up to 15°
3	protected against solid foreign objects of 2,5 mm \varnothing and greater	3	protected against spraying water (rain up to a slope of 60°)
4	Protected against solid foreign objects of 1,0 mm \varnothing and greater	4	protected against splashing water
5	dust - protected	5	protected against water jets
6	dust - tight	6	protected against powerful water jets
		7	protected against temporary immersion in water (0,15 to 1 m depth, 30 min.)
		8	protected against continuous submersion in water under defined pressure and time

Faster and more comfortable installation, average mounting time shortened by 39%. The total length of plugs and sockets was significantly shortened.

Body covers of plugs and sockets are supplied in unlocked but still transport-safe position for faster mounting.

A new design of a cable inlet bushing as well as the ergonomic shape of a sealing nut improves manipulation while mounting the cable and its sealing.



The appropriate colours of actuating levers are used for clear identification: L1, L2, L3, N, and PE. Contacts are supplied in open stand-by position for faster wires mounting.

The lamellar clasp remains safely locked by two serrations in the body of the product even during the manipulation with a cable.

MARKING OF PRODUCTS:

Key for industrial plugs and inlets

Key for industrial sockets

Example of marking

I	V	G	N	63	5	3
I	x	G	N	x	x	x

- I - industrial
- V - cable plug
- P - wall inlet
- R - inlet
- RR - panel inlet straight

G - degree of protection IP 67

- N - new series
- NO - reversing
- B - screwless

- Voltage**
- 1 - 100 V
 - 2 - 230 V
 - 3 - 400 V
 - 5 - 500 V

- Number of poles**
- 3 - 3 poles
 - 4 - 4 poles
 - 5 - 5 poles

- Current**
- 16 - 16 A
 - 32 - 32 A
 - 63 - 63 A
 - 125 - 125 A

Example of marking

I	Z	G	N	63	5	3
I	x	G	N	x	x	x

- I - industrial
- S - cable socket
- Z - wall socket
- E - panel socket
- ER - panel socket straight

G - degree of protection IP 67

- N - new series
- B - screwless
- VZ - wall socket-combined
- V - wall sockets with box under plaster
- VN - wall sockets with box

- Voltage**
- 1 - 100 V
 - 2 - 230 V
 - 3 - 400 V
 - 5 - 500 V

- Number of poles**
- 3 - 3 poles
 - 4 - 4 poles
 - 5 - 5 poles

- Current**
- 16 - 16 A
 - 32 - 32 A
 - 63 - 63 A
 - 125 - 125 A



COLOUR CODES:

To facilitate the identification of different are all CEE plugs and sockets colour coded.

Nominal voltage	Colour code
20 – 25 V	violet
100 – 130 V	yellow
200 – 250 V	blue
380 – 480 V	red
500 – 690 V	black

Hour position of the earthing contact.
View: frontside socket.

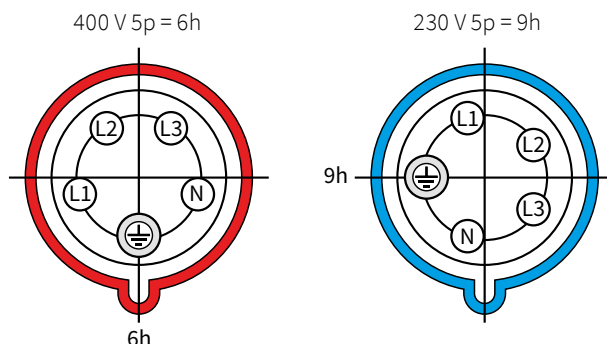

CEE Plug-in devices for operating voltages above 50 V.

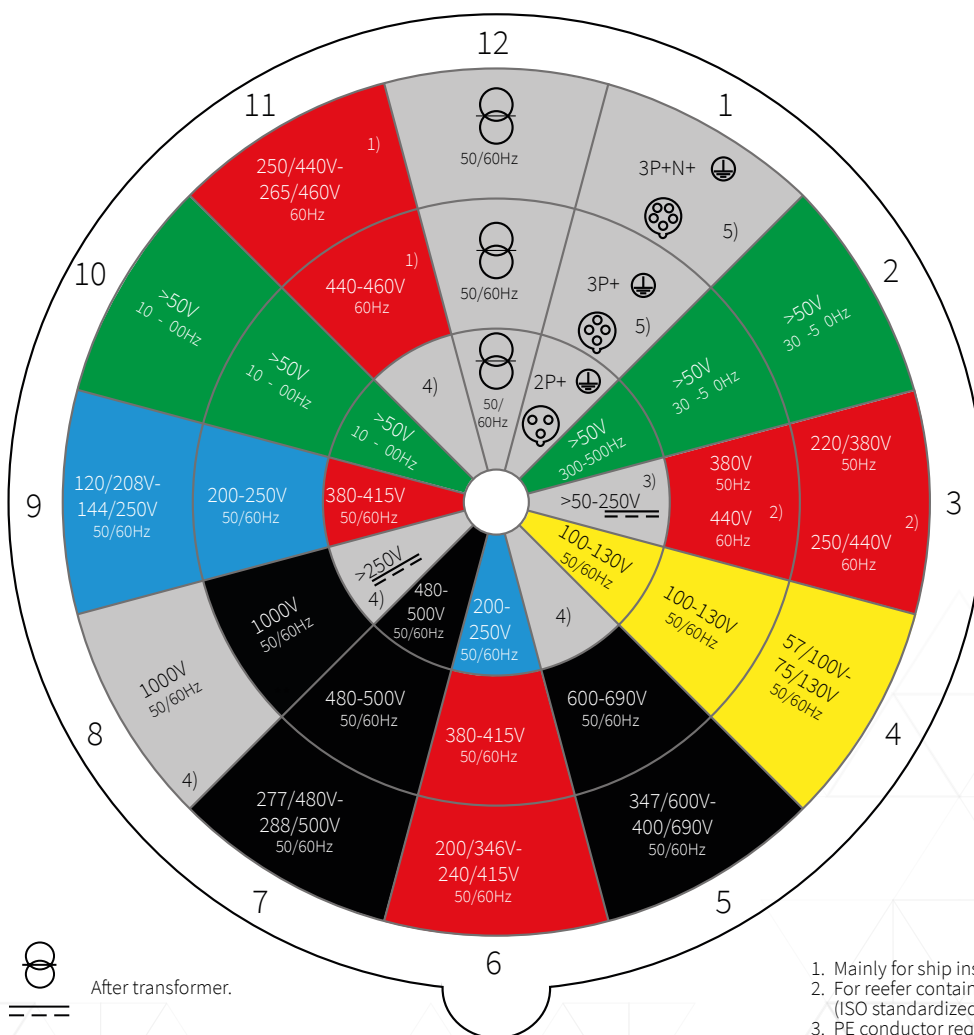

After transformer.

1. Mainly for ship installations.
2. For reefer containers only (ISO standardized).
3. PE conductor required.
4. Not used clock positions.
5. Clock positions not normed and free for use for special applications.

Cable plugs IP44 - 16 A/ 32 A

- Screw contacts.
- 16 A - flexible conductors 1 - 2,5 mm².
- 32 A - flexible conductors 2,5 - 6 mm².



100014

Complies with standards: IEC 60309-1, -2
STN EN 60309-1, -2
Material: PA6, ABS
Surface treatment contacts: passivated brass
Operating temperature: -25 °C to +55 °C

Amp.	Poles	110 V~ 50/60 Hz	230 V~ 50/60 Hz	400 V~ 50/60 Hz	500 V~ 50/60 Hz	Pkg. (pcs.)
		4h	3p=6h 4p+5p=9h	3p=9h 4p+5p=6h	7h	
		Ord. No. (Type)				
16	3	100000 (IVN 1631)	100006 (IVN 1632)		100018 (IVN 1635)	10/10/ - / 10
16	4	100001 (IVN 1641)	100007 (IVN 1642)	100013 (IVN 1643)	100019 (IVN 1645)	10/10/10/10
16	5	100002 (IVN 1651)	100008 (IVN 1652)	100014 (IVN 1653)	100020 (IVN 1655)	10/10/10/10
32	3	100003 (IVN 3231)	100009 (IVN 3232)		100021 (IVN 3235)	10/10/ - / 10
32	4	100004 (IVN 3241)	100010 (IVN 3242)	100016 (IVN 3243)	100022 (IVN 3245)	10/10/10/10
32	5	100005 (IVN 3251)	100011 (IVN 3252)	100017 (IVN 3253)	100023 (IVN 3255)	10/10/10/10

Cable plugs - Screwless IP44 - 16 A/32 A

- Screwless contacts.
- Self-locking click system of cover.
- Lamellar gland for fixing and sealing the cable without the use of a tool.
- Miniature dimensions with ergonomic grip and lid opening.
- 16 A - flexible conductors 1 - 2,5 mm².
- 32 A - flexible conductors 2,5 - 6 mm².



100104

Complies with standards: IEC 60309-1, -2
STN EN 60309-1, -2
Material: PA6, ABS
Surface treatment contacts: passivated brass
Operating temperature: -25 °C to +55 °C

Amp.	Poles	110 V~ 50/60 Hz	230 V~ 50/60 Hz	400 V~ 50/60 Hz	500 V~ 50/60 Hz	Pkg. (pcs.)
		4h	3p=6h 4p+5p=9h	3p=9h 4p+5p=6h	7h	
		Ord. No. (Type)				
16	3	100090 (IVB 1631)	100096 (IVB 1632)			10/10/ - / -
16	4	100091 (IVB 1641)	100097 (IVB 1642)	100103 (IVB 1643)		10/10/10/-
16	5	100092 (IVB 1651)	100098 (IVB 1652)	100104 (IVB 1653)		10/10/10/-
32	3	100093 (IVB 3231)	100099 (IVB 3232)			10/10/ - / -
32	4	100094 (IVB 3241)	100100 (IVB 3242)	100106 (IVB 3243)		10/10/10/-
32	5	100095 (IVB 3251)	100101 (IVB 3252)	100107 (IVB 3253)		10/10/10/-

Cable plugs - Phase reverse IP44 - 16 A/32 A

- Screw contacts.
- 16 A - flexible conductors 1 - 2,5 mm².
- 32 A - flexible conductors 2,5 - 6 mm².
- In position can be changed by turning the screwdriver by 180 degrees to achieve the phase change.



100194

Complies with standards: IEC 60309-1, -2
STN EN 60309-1, -2
Material: PA6, ABS
Surface treatment contacts: passivated brass
Operating temperature: -25 °C to +55 °C

Amp.	Poles	110 V~ 50/60 Hz	230 V~ 50/60 Hz	400 V~ 50/60 Hz	500 V~ 50/60 Hz	Pkg. (pcs.)
		4h	3p=6h 4p+5p=9h	3p=9h 4p+5p=6h	7h	
		Ord. No. (Type)				
16	4			100193 (IVNO 1643)		- / - / 10 / -
16	5			100194 (IVNO 1653)		- / - / 10 / -
32	4			100196 (IVNO 3243)		- / - / 10 / -
32	5			100197 (IVNO 3253)		- / - / 10 / -



Cable plugs IP44 - 16 A/ 32 A

Amp	Poles	Ord. No.	Dimensions (mm)			
			A	B	C	R
16	3	100006	124	88	47	7,5 - 15
		100000, 100018	122	86	47	6 - 15
16	4	100013	124	88	53	7,5 - 15
		100001, 100007, 100019	128	92	53	6 - 15
16	5	100014	124	88	61	7,5 - 15
		100002, 100008, 100020	134	98	61	8 - 16
32	3	100009	150	105	63	11 - 20
		100003, 100021	150	104	63	11,5 - 20
32	4	100016	150	105	63	11 - 20
		100004, 100010, 100022	150	104	63	11,5 - 20
32	5	100017	150	105	70	11 - 20
		100005, 100011, 100023	155	109	70	11,5 - 22

R - sealing range

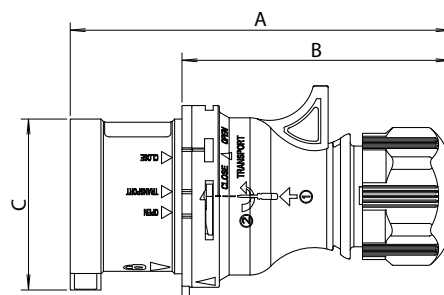

Cable plugs - Screwless IP44 - 16 A/32 A

Amp	Poles	Ord. No.	Dimensions (mm)			
			A	B	C	R
16	3	100090, 100096	122	86	47	6 - 15
16	4	100091, 100097, 100103	128	92	53	6 - 15
16	5	100104	132	88	61	7,5 - 15
		100092, 100098	134	98	61	8 - 16
32	3	100093, 100099	150	104	63	11,5 - 20
32	4	100094, 100100, 100106	150	104	63	11,5 - 20
32	5	100107	160	105	70	11 - 20
		100095, 100101	155	109	70	11,5 - 22

R - sealing range

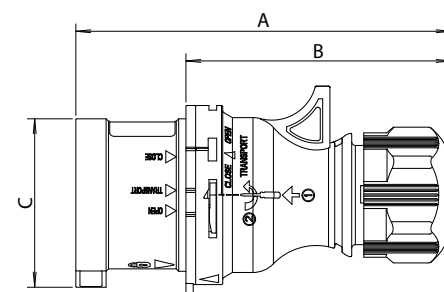

Cable plugs - Phase reverse IP44 - 16 A/32 A

Amp	Poles	Ord. No.	Dimensions (mm)			
			A	B	C	R
16	4	100193	128	92	53	6 - 15
16	5	100194	132	88	61	7,5 - 15
32	4	100196	150	104	63	11,5 - 20
32	5	100197	160	105	70	11 - 20

R - sealing range

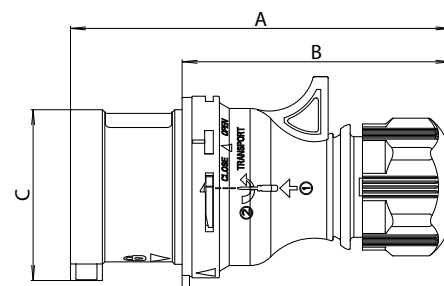

Cable plugs IP44 - 63 A

- Screw contacts.
- Flexible conductors 6 - 16 mm².



100278

Complies with standards: IEC 60309-1, -2
STN EN 60309-1, -2
Material: PA6, ABS
Surface treatment contacts: nickel-plated brass
Operating temperature: -25 °C to +55 °C

Amp.	Poles	110 V~ 50/60 Hz	230 V~ 50/60 Hz	400 V~ 50/60 Hz	500 V~ 50/60 Hz	Pkg. (pcs.)
		4h	3p=6h 4p+5p=9h	3p=9h 4p+5p=6h	7h	
63	3	100273 (IVN 6332)				- / 2 / - / -
63	4			100277 (IV 6343)	100280 (IV 6345)	- / - / 2 / 2
63	5			100278 (IVN 6353)		- / - / 2 / -

Cable plugs IP67 - 16 A/32 A

- Screw contacts.
- 16 A - flexible conductors 1 - 2,5 mm².
- 32 A - flexible conductors 2,5 - 6 mm².



100364

Complies with standards: IEC 60309-1, -2
STN EN 60309-1, -2
Material: PA6, ABS
Surface treatment contacts: passivated brass
Operating temperature: -25 °C to +55 °C

Amp.	Poles	110 V~ 50/60 Hz	230 V~ 50/60 Hz	400 V~ 50/60 Hz	500 V~ 50/60 Hz	Pkg. (pcs.)
		4h	3p=6h 4p+5p=9h	3p=9h 4p+5p=6h	7h	
16	3	100350 (IVG 1631)	100356 (IVG 1632)		100368 (IVG 1635)	10 / 5 / - / 10
16	4	100351 (IVG 1641)	100357 (IVG 1642)	100363 (IVG 1643)	100369 (IVG 1645)	10 / 10 / 5 / 10
16	5	100352 (IVG 1651)		100364 (IVG 1653)	100370 (IVG 1655)	10 / - / 5 / 10
32	3	100353 (IVG 3231)	100359 (IVG 3232)		100371 (IVG 3235)	10 / 5 / - / 10
32	4	100354 (IVG 3241)	100360 (IVG 3242)	100366 (IVG 3243)	100372 (IVG 3245)	10 / 10 / 5 / 10
32	5	100355 (IVG 3251)		100367 (IVG 3253)	100373 (IVG 3255)	10 / - / 5 / 10

Cable plugs - Screwless IP67 - 16 A/32 A

- Screwless contacts.
- 16 A - flexible conductors 1 - 2,5 mm².
- 32 A - flexible conductors 2,5 - 6 mm².



100464

Complies with standards: IEC 60309-1, -2
STN EN 60309-1, -2
Material: PA6, ABS
Surface treatment contacts: passivated brass
Operating temperature: -25 °C to +55 °C

Amp.	Poles	110 V~ 50/60 Hz	230 V~ 50/60 Hz	400 V~ 50/60 Hz	500 V~ 50/60 Hz	Pkg. (pcs.)
		4h	3p=6h 4p+5p=9h	3p=9h 4p+5p=6h	7h	
16	3	100450 (IVGB 1631)	100456 (IVGB 1632)			10 / 10 / - / -
16	4	100451 (IVGB 1641)	100457 (IVGB 1642)	100463 (IVGB 1643)		10 / 10 / 10 / -
16	5	100452 (IVGB 1651)	100458 (IVGB 1652)	100464 (IVGB 1653)		10 / 10 / 10 / -
32	3	100453 (IVGB 3231)	100459 (IVGB 3232)			10 / 10 / - / -
32	4	100454 (IVGB 3241)	100460 (IVGB 3242)	100466 (IVGB 3243)		10 / 10 / 10 / -
32	5	100455 (IVGB 3251)	100461 (IVGB 3252)	100467 (IVGB 3253)		10 / 10 / 10 / -



Cable plugs IP44 - 63 A

Amp	Poles	Ord. No.	Dimensions (mm)			
			A	B	ØC	R
63	3	100273	250	184	102	14,5 - 36
63	4	100277, 100280	239	142	83	16 - 26
63	5	100278	245	178	101	16 - 32,5

R - sealing range

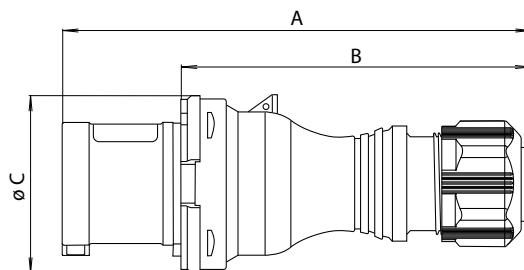

Cable plugs IP67 - 16 A/32 A

Amp	Poles	Ord. No.	Dimensions (mm)		
			A	ØB	R
16	3	100356	149	70	9 - 16
		100350, 100368	122	71	6 - 15
16	4	100363	155	78	9 - 16
		100351, 100357, 100369	128	92	6 - 15
16	5	100364	155	87	9 - 16
		100352, 100370	134	98	8 - 16
32	3	100359	174	92	12 - 18
		100353, 100371	150	93	11,5 - 20
32	4	100366	174	92	12 - 18
		100354, 100360, 100372	150	93	11,5 - 20
32	5	100367	174	100	12 - 18
		100355, 100373	155	100	11,5 - 22

R - sealing range

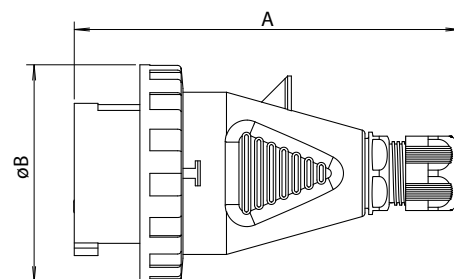

Cable plugs - Screwless IP67 - 16 A/32 A

Amp	Poles	Ord. No.	Dimensions (mm)		
			A	ØB	R
16	3	100450, 100456	122	71	6 - 15
16	4	100451, 100457, 100463	128	79	6 - 15
16	5	100452, 100458, 100464	134	87	8 - 16
32	3	100453, 100459	150	93	11,5 - 20
32	4	100454, 100460, 100466	150	93	11,5 - 20
32	5	100455, 100461, 100467	155	100	11,5 - 22

R - sealing range

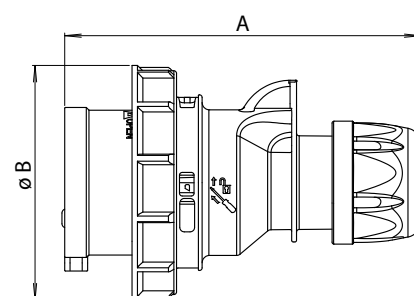

Cable plugs IP67 - 63 A

- Screw contacts.
- Flexible conductors 6 - 16 mm².



100538

Complies with standards: IEC 60309-1, -2
STN EN 60309-1, -2
Material: PA6, ABS
Surface treatment contacts: nickel-plated brass
Operating temperature: -25 °C to +55 °C

Amp.	Poles	110 V~ 50/60 Hz	230 V~ 50/60 Hz	400 V~ 50/60 Hz	500 V~ 50/60 Hz	Pkg. (pcs.)
		4h	3p=6h 4p+5p=9h	3p=9h 4p+5p=6h	7h	
63	3	100530 (IVGN 6331)	100533 (IVGN 6332)			2 / 2 / - / -
63	4	100531 (IVGN 6341)		100537 (IVG 6343)	100540 (IVG 6345)	2 / - / 2 / 2
63	5	100532 (IVGN 6351)		100538 (IVGN 6353)		2 / - / 2 / -

Cable plugs IP67 -125 A

- Screw contacts.
- Flexible conductors 16 - 50 mm².



100618

Complies with standards: IEC 60309-1, -2
STN EN 60309-1, -2
Material: PA6, ABS
Surface treatment contacts: nickel-plated brass
Operating temperature: -25 °C to +55 °C

Amp.	Poles	110 V~ 50/60 Hz	230 V~ 50/60 Hz	400 V~ 50/60 Hz	500 V~ 50/60 Hz	Pkg. (pcs.)
		4h	3p=6h 4p+5p=9h	3p=9h 4p+5p=6h	7h	
125	3	100610 (IVGN 12531)	100613 (IVGN 12532)			2 / 2 / - / -
125	4	100611 (IVGN 12541)		100617 (IVGN 12543)	100620 (IVGN 12545)	2 / - / 2 / 2
125	5	100612 (IVGN 12551)		100618 (IVGN 12553)	100621 (IVGN 12555)	2 / - / 2 / 2

House plug Uni-schuko, sockets Schuko and French IP67 - 16 A

- Screw contacts.
- The plug Uni-Schuko ord. No. 100696 is IP 67 compatible with sockets ord. No. 103790, 103791, 103792.
- Flexible conductors 1 - 2,5 mm².



100696



100698

Complies with standards: IEC 60309-1, -2
STN EN 60309-1, -2
Material: PA6, ABS
Surface treatment contacts: passivated brass
Operating temperature: -25 °C to +55 °C

Amp.	Poles	250 V~ 50/60 Hz	System	Pkg. (pcs.)
		3p=6h 4p+5p=9h		
16	3	100696 (PVG 16)	plug Uni-Schuko	1
16	3	100697 (PSG 16)	socket French	1
16	3	100698 (PSG 16/S)	socket Schuko	1



Cable plugs IP67 - 63 A

Amp	Poles	Ord. No.	Dimensions (mm)		
			A	ØB	R
63	3	100530, 100533	250	115	14,5 - 36
63	4	100537, 100540	254	113	16 - 26
		100531	250	115	14,5 - 36
63	5	100538	265	111	16 - 32,5
		100532	250	115	14,5 - 36

R - sealing range

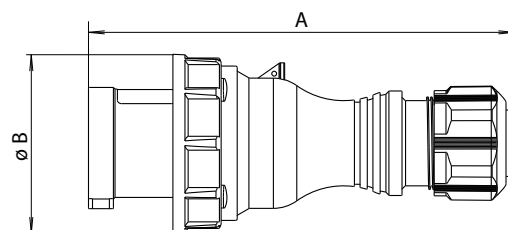

Cable plugs IP67 - 125 A

Amp	Poles	Ord. No.	Dimensions (mm)		
			A	ØB	R
125	3	100610, 100613	270	131	22,5 - 50
125	4	100611, 100617, 100620	270	131	22,5 - 50
125	5	100612, 100618, 100621	270	131	22,5 - 50

R - sealing range

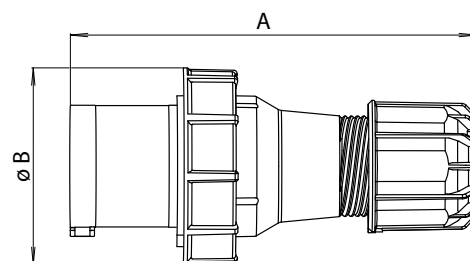

House plug Uni-schuko, sockets Schuko and French IP67 - 16 A

Amp	Poles	Ord. No.	Dimensions (mm)		
			A	ØB	R
16	3	100696	137	58	7,5 - 12,6
16	4	100697	108	58	7,5 - 12,6
16	5	100698	108	58	7,5 - 12,6

R - sealing range

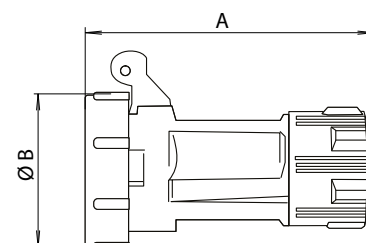
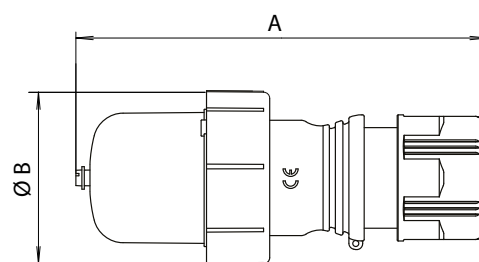

Cable sockets IP44 - 16 A/32 A

- Screw contacts.
- Self-locking click system of cover.
- Lamellar gland for fixing and sealing the cable without the use of a tool.
- Miniature dimensions with ergonomic grip and lid opening.
- 16 A - flexible conductors 1 - 2,5 mm².
- 32 A - flexible conductors 2,5 - 6 mm².



100743

Complies with standards: IEC 60309-1, -2
STN EN 60309-1, -2
Material: PA6, ABS
Surface treatment contacts: passivated brass
Operating temperature: -25 °C to +55 °C

Amp.	Poles	110 V~ 50/60 Hz	230 V~ 50/60 Hz	400 V~ 50/60 Hz	500 V~ 50/60 Hz	Pkg. (pcs.)
		4h	3p=6h 4p+5p=9h	3p=9h 4p+5p=6h	7h	
16	3	100730 (ISN 1631)	100736 (ISN 1632)		100748 (ISN 1635)	10/10/ - /10
16	4	100731 (ISN 1641)	100737 (ISN 1642)	100743 (ISN 1643)	100749 (ISN 1645)	10/10/10/10
16	5	100732 (ISN 1651)	100738 (ISN 1652)	100744 (ISN 1653)	100750 (ISN 1655)	10/10/10/10
32	3	100733 (ISN 3231)	100739 (ISN 3232)		100751 (ISN 3235)	10/10/ - /10
32	4	100734 (ISN 3241)	100740 (ISN 3242)	100746 (ISN 3243)	100752 (ISN 3245)	10/10/10/10
32	5	100735 (ISN 3251)	100741 (ISN 3252)	100747 (ISN 3253)	100753 (ISN 3255)	10/10/10/10

Cable sockets IP44 - 63 A

- Screw contacts.
- Self-locking click system of cover.
- Lamellar gland for fixing and sealing the cable without the use of a tool.
- Miniature dimensions with ergonomic grip and lid opening.
- Flexible conductors 6 - 16 mm².



100828

Complies with standards: IEC 60309-1, -2
STN EN 60309-1, -2
Material: PA6, ABS
Surface treatment contacts: nickel-plated brass
Operating temperature: -25 °C to +55 °C

Amp.	Poles	110 V~ 50/60 Hz	230 V~ 50/60 Hz	400 V~ 50/60 Hz	500 V~ 50/60 Hz	Pkg. (pcs.)
		4h	3p=6h 4p+5p=9h	3p=9h 4p+5p=6h	7h	
63	3		100823 (ISN 6332)			- / 2/ - /-
63	4			100827 (IS 6343)	100830 (IS 6345)	- / - / 2/2
63	5			100828 (ISN 6353)		- / - / 2/-

Cable sockets - Screwless IP44 - 16 A/32 A

- Screwless contacts.
- Self-locking click system of cover.
- Lamellar gland for fixing and sealing the cable without the use of a tool.
- Miniature dimensions with ergonomic grip and lid opening.
- 16 A - flexible conductors 1 - 2,5 mm².
- 32 A - flexible conductors 2,5 - 6 mm².



100914

Complies with standards: IEC 60309-1, -2
STN EN 60309-1, -2
Material: PA6, ABS
Surface treatment contacts: passivated brass
Operating temperature: -25 °C to +55 °C

Amp.	Poles	110 V~ 50/60 Hz	230 V~ 50/60 Hz	400 V~ 50/60 Hz	500 V~ 50/60 Hz	Pkg. (pcs.)
		4h	3p=6h 4p+5p=9h	3p=9h 4p+5p=6h	7h	
16	3	100900 (ISB 1631)	100906 (ISB 1632)			10/10/ - /-
16	4	100901 (ISB 1641)	100907 (ISB 1642)	100913 (ISB 1643)		10/10/10/-
16	5	100902 (ISB 1651)	100908 (ISB 1652)	100914 (ISB 1653)		10/10/10/-
32	3	100903 (ISB 3231)	100909 (ISB 3232)			10/10/ - /-
32	4	100904 (ISB 3241)	100910 (ISB 3242)	100916 (ISB 3243)		10/10/10/-
32	5	100905 (ISB 3251)	100911 (ISB 3252)	100917 (ISB 3253)		10/10/10/-

Products may differ from the illustration.



Cable sockets IP44 - 16 A/32 A

Amp	Poles	Ord. No.	Dimensions (mm)		
			A	B	R
16	3	100736	145	79	7,5 - 15
		100730, 100748	133	74	6 - 15
16	4	100743	145	82	7,5 - 15
		100731, 100737, 100749	138	82	6 - 15
16	5	100744	145	89	7,5 - 15
		100732, 100738, 100750	145	89	8 - 16
32	3	100739	172	96	11 - 20
		100733, 100751	161	94	11,5 - 20
32	4	100746	177	96	11 - 20
		100734, 100740, 100752	161	94	11,5 - 20
32	5	100747	177	103	11 - 20
		100735, 100741, 100753	168	99	11,5 - 22

R - sealing range

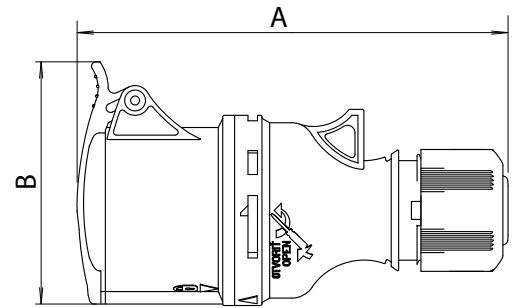

Cable sockets IP44 - 63 A

Amp	Poles	Ord. No.	Dimensions (mm)		
			A	B	R
63	3	100823	269	107	14,5 - 36
63	4	100827, 100830	269	107	14,5 - 36
63	5	100828	269	107	14,5 - 36

R - sealing range

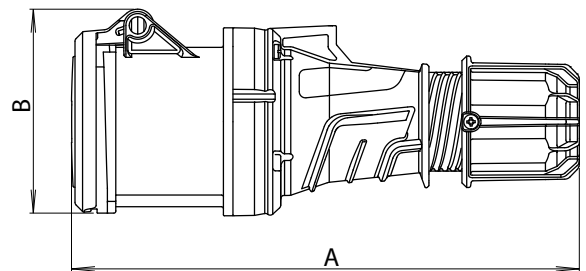

Cable sockets - Screwless IP44 - 16 A/32 A

Amp	Poles	Ord. No.	Dimensions (mm)		
			A	B	R
16	3	100900, 100906	133	74	6 - 15
16	4	100901, 100907, 100913	138	82	7,5 - 15
16	5	100914	145	89	7,5 - 15
		100902, 100908	145	89	8 - 16
32	3	100903, 100909	161	94	11,5 - 20
32	4	100904, 100910, 100916	161	94	11,5 - 20
32	5	100917	177	103	11 - 20
		100905, 100911	168	99	11,5 - 22

R - sealing range

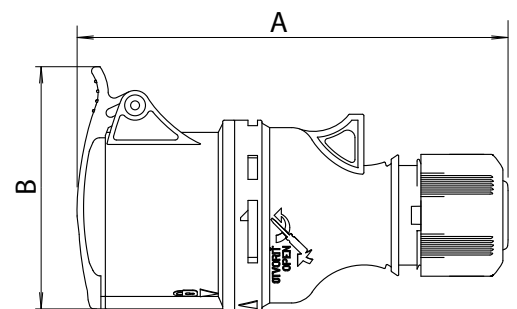

Cable sockets IP67 - 16 A/32 A

- Screw contacts.
- Self-locking click system of cover.
- Lamellar gland for fixing and sealing the cable without the use of a tool.
- Miniature dimensions with ergonomic grip and lid opening.
- 16 A - flexible conductors 1 - 2,5 mm².
- 32 A - flexible conductors 2,5 - 6 mm².



101004

Complies with standards: IEC 60309-1, -2
STN EN 60309-1, -2
Material: PA6, ABS
Surface treatment contacts: passivated brass
Operating temperature: -25 °C to +55 °C

Amp.	Poles	Ord. No. (Type)				Pkg. (pcs.)
		110 V~ 50/60 Hz 4h	230 V~ 50/60 Hz 3p=6h 4p+5p=9h	400 V~ 50/60 Hz 3p=9h 4p+5p=6h	500 V~ 50/60 Hz 7h	
16	3	100990 (ISG 1631)	100996 (ISG 1632)		101008 (ISG 1635)	10 / 5 / - / 10
16	4	100991 (ISG 1641)	100997 (ISG 1642)	101003 (ISG 1643)	101009 (ISG 1645)	10 / 10 / 5 / 10
16	5	100992 (ISG 1651)		101004 (ISG 1653)	101010 (ISG 1655)	10 / - / 5 / 10
32	3	100993 (ISG 3231)	100999 (ISG 3232)		101011 (ISG 3235)	10 / 5 / - / 10
32	4	100994 (ISG 3241)	101000 (ISG 3242)	101006 (ISG 3243)	101012 (ISG 3245)	10 / 10 / 5 / 10
32	5	100995 (ISG 3251)		101007 (ISG 3253)	101013 (ISG 3255)	10 / - / 5 / 10

Cable sockets - Screwless IP67 - 16 A/32 A

- Screwless contacts.
- Self-locking click system of cover.
- Miniature dimensions with ergonomic grip and lid opening.
- 16 A - flexible conductors 1 - 2,5 mm².
- 32 A - flexible conductors 2,5 - 6 mm².



101094

Complies with standards: IEC 60309-1, -2
STN EN 60309-1, -2
Material: PA6, ABS
Surface treatment contacts: passivated brass
Operating temperature: -25 °C to +55 °C

Amp.	Poles	Ord. No. (Type)				Pkg. (pcs.)
		110 V~ 50/60 Hz 4h	230 V~ 50/60 Hz 3p=6h 4p+5p=9h	400 V~ 50/60 Hz 3p=9h 4p+5p=6h	500 V~ 50/60 Hz 7h	
16	3	101080 (ISGB 1631)	101086 (ISGB 1632)			10 / 10 / - / -
16	4	101081 (ISGB 1641)	101087 (ISGB 1642)	101093 (ISGB 1643)		10 / 10 / 10 / -
16	5	101082 (ISGB 1651)	101088 (ISGB 1652)	101094 (ISGB 1653)		10 / 10 / 10 / -
32	3	101083 (ISGB 3231)	101089 (ISGB 3232)			10 / 10 / - / -
32	4	101084 (ISGB 3241)	101090 (ISGB 3242)	101096 (ISGB 3243)		10 / 10 / 10 / -
32	5	101085 (ISGB 3251)	101091 (ISGB 3252)	101097 (ISGB 3253)		10 / 10 / 10 / -

Cable sockets IP67 - 63 A

- Screw contacts.
- Self-locking click system of cover.
- Lamellar gland for fixing and sealing the cable without the use of a tool.
- Miniature dimensions with ergonomic grip and lid opening.
- Flexible conductors 6 - 16 mm².



101178

Complies with standards: IEC 60309-1, -2
STN EN 60309-1, -2
Material: PA6, ABS
Surface treatment contacts: nickel-plated brass
Operating temperature: -25 °C to +55 °C

Amp.	Poles	Ord. No. (Type)				Pkg. (pcs.)
		110 V~ 50/60 Hz 4h	230 V~ 50/60 Hz 3p=6h 4p+5p=9h	400 V~ 50/60 Hz 3p=9h 4p+5p=6h	500 V~ 50/60 Hz 7h	
63	3	101170 (ISGN 6331)	101173 (ISGN 6332)			2 / 2 / - / -
63	4	101171 (ISGN 6341)		101177 (ISGN 6343)	101180 (ISGN 6345)	2 / - / 2 / 2
63	5	101172 (ISGN 6351)		101178 (ISGN 6353)		2 / - / 2 / -

Products may differ from the illustration.

Cable sockets IP67 - 16 A/32 A

Amp	Poles	Ord. No.	Dimensions (mm)		
			A	B	R
16	3	100996	161	78	9 - 16
		100990, 101008	132	78	6 - 15
16	4	101003	167	86	9 - 16
		100991, 100997, 101009	139	84	6 - 15
16	5	101004	168	92	9 - 16
		100992, 101010	147	92	8 - 16
32	3	100999	189	101	12 - 18
		100993, 101011	163	96	11,5 - 20
32	4	101006	189	101	12 - 18
		100994, 101000, 101012	163	96	11,5 - 20
32	5	101007	189	108	12 - 18
		100995, 101013	171	102	11,5 - 22

R - sealing range

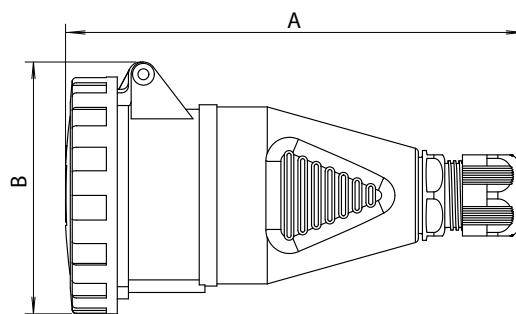

Cable sockets - Screwless IP67 - 16 A/32 A

Amp	Poles	Ord. No.	Dimensions (mm)		
			A	B	R
16	3	101080, 101086	132	78	6 - 15
16	4	101081, 101087, 101093	139	84	6 - 15
16	5	101082, 101088, 101094	147	92	8 - 16
32	3	101083, 101089	163	96	11,5 - 20
32	4	101084, 101090, 101096	163	96	11,5 - 20
32	5	101085, 101091, 101097	171	102	11,5 - 22

R - sealing range

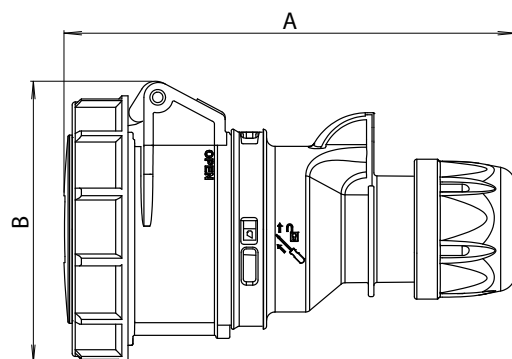

Cable sockets IP67 - 63 A

Amp	Poles	Ord. No.	Dimensions (mm)		
			A	B	R
63	3	101170, 101173	269	114	14,5 - 36
63	4	101177, 101180	254	113	16 - 26
		101171	269	114	14,5 - 36
63	5	101178	283	110	16 - 32,5
		101172	269	114	14,5 - 36

R - sealing range

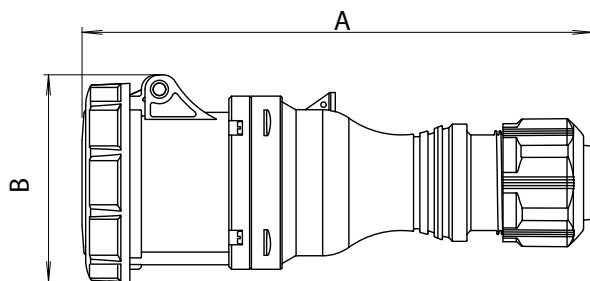

Cable sockets IP67 - 125 A

- Screw contacts.
- Self-locking click system of cover.
- Lamellar gland for fixing and sealing the cable without the use of a tool.
- Miniature dimensions with ergonomic grip and lid opening.
- Flexible conductors 16 - 50 mm².



101270

Complies with standards: IEC 60309-1, -2
STN EN 60309-1, -2
Material: PA6, ABS
Surface treatment contacts: nickel-plated brass
Operating temperature: -25 °C to +55 °C

Amp.	Poles	110 V~ 50/60 Hz				230 V~ 50/60 Hz				400 V~ 50/60 Hz				500 V~ 50/60 Hz					
		4h				3p=6h 4p+5p=9h				3p=9h 4p+5p=6h				7h					
		Ord. No. (Type)																Pkg. (pcs.)	
125	3	101250 (ISGN 12531)				101259 (ISGN 12532)												2 / 2 / - / -	
125	4	101251 (ISGN 12541)								101269 (ISGN 12543)				101278 (ISGN 12545)				2 / - / 2 / 2	
125	5	101252 (ISGN 12551)								101270 (ISGN 12553)				101279 (ISGN 12555)				2 / - / 2 / 2	

With pilot contact

125	3	101253 (ISGN 12531-p)				101262 (ISGN 12532-p)								2 / 2 / - / -					
125	4	101254 (ISGN 12541-p)								101272 (ISGN 12543-p)				101281 (ISGN 12545-p)				2 / - / 2 / 2	
125	5	101255 (ISGN 12551-p)								101273 (ISGN 12553-p)				101282 (ISGN 12555-p)				2 / - / 2 / 2	

Wall sockets IP44 - 16 A/32 A

- Screw contacts.
- 16 A - flexible/rigid conductors 1 - 2,5/1 - 4 mm².
- 32 A - flexible/rigid conductors 2,5 - 6/2,5 - 10 mm².



101363

Complies with standards: IEC 60309-1, -2
STN EN 60309-1, -2
Material: PA6, ABS
Surface treatment contacts: passivated brass
Operating temperature: -25 °C to +55 °C

Amp.	Poles	110 V~ 50/60 Hz				230 V~ 50/60 Hz				400 V~ 50/60 Hz				500 V~ 50/60 Hz					
		4h				3p=6h 4p+5p=9h				3p=9h 4p+5p=6h				7h					
		Ord. No. (Type)																Pkg. (pcs.)	
16	3	101350 (IZN 1631)				101356 (IZN 1632)				101362 (IZN 1633)				101368 (IZN 1635)				10 / 10 / 10 / 10	
16	4	101351 (IZN 1641)				101357 (IZN 1642)				101363 (IZN 1643)				101369 (IZN 1645)				10 / 10 / 10 / 10	
16	5	101352 (IZN 1651)				101358 (IZN 1652)				101364 (IZN 1653)				101370 (IZN 1655)				10 / 10 / 10 / 10	
32	3	101353 (IZN 3231)				101359 (IZN 3232)				101365 (IZN 3233)				101371 (IZN 3235)				10 / 10 / 10 / 10	
32	4	101354 (IZN 3241)				101360 (IZN 3242)				101366 (IZN 3243)				101372 (IZN 3245)				10 / 10 / 10 / 10	
32	5	101355 (IZN 3251)				101361 (IZN 3252)				101367 (IZN 3253)				101373 (IZN 3255)				10 / 10 / 10 / 10	

Wall sockets IP44 - 16 A/32 A Loop

- Screw contacts.
- 16 A - flexible/rigid conductors 1 - 2,5/1 - 4 mm².
- 32 A - flexible/rigid conductors 2,5 - 6/2,5 - 10 mm².
- Loop - raised socket base for looping. (standard)
- Loop ready - added 5-pole terminal block not connected. (on request)
- Loop complete - added 5-pole connected terminal block. (on request)



101454

Complies with standards: IEC 60309-1, -2
STN EN 60309-1, -2
Material: PA6, ABS
Surface treatment contacts: passivated brass
Operating temperature: -25 °C to +55 °C

Amp.	Poles	110 V~ 50/60 Hz				230 V~ 50/60 Hz				400 V~ 50/60 Hz				500 V~ 50/60 Hz					
		4h				3p=6h 4p+5p=9h				3p=9h 4p+5p=6h				7h					
		Ord. No. (Type)																Pkg. (pcs.)	
16	3	101440 (IZN 1631 L)				101446 (IZN 1632 L)												5 / 5 / - / -	
16	4					101447 (IZN 1642 L)				101453 (IZN 1643 L)								- / 5 / 5 / -	
16	5					101448 (IZN 1652 L)				101454 (IZN 1653 L)								- / 5 / 5 / -	
32	3	101443 (IZN 3231 L)				101449 (IZN 3232 L)												5 / 5 / - / -	
32	4					101450 (IZN 3242 L)				101456 (IZN 3243 L)								- / 5 / 5 / -	
32	5					101451 (IZN 3252 L)				101457 (IZN 3253 L)								- / 5 / 5 / -	

Products may differ from the illustration.

Cable sockets IP67 - 125 A

Amp	Poles	Ord. No.	Dimensions (mm)		
			A	B	R
125	3	101250, 101259	287	124	22,5 - 50
125	4	101251, 101269, 101278	287	124	22,5 - 50
125	5	101252, 101270, 101279	287	124	22,5 - 50
With pilot contact					
125	3	101253, 101262	287	124	22,5 - 50
125	4	101254, 101272, 101281	287	124	22,5 - 50
125	5	101255, 101273, 101282	287	124	22,5 - 50

R - sealing range

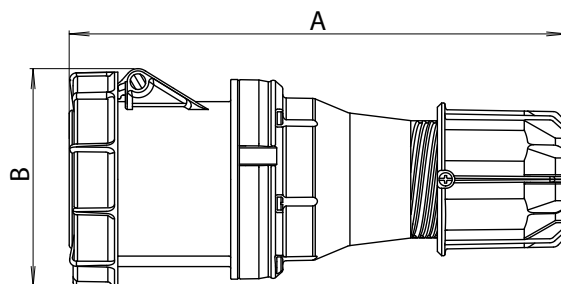

Wall sockets IP44 - 16 A/32 A

Amp	Poles	Ord. No.	Dimensions (mm)												
			A	B	C	Ød	D1	D2	E1	E2	F	G	H	R	
16	3	101356	157	90	78	5	-	18	53	30	58	-	96	8 - 22	
		101350, 101362, 101368	142	97	85	5	19	-	67	-	50	104	-	M 25	
16	4	101363	157	99	78	5	-	18	53	30	58	-	96	8 - 22	
		101351, 101357, 101369	145	98	85	5	19	-	67	-	50	104	-	M 25	
16	5	101364	158	104	78	5	-	18	53	30	58	-	96	8 - 22	
		101352, 101358, 101370	144	104	85	5	19	-	67	-	50	104	-	M 25	
32	3	101359	179	118	88	5	-	24	62	35	60	-	108	8 - 22	
		101353, 101365, 101371	155	106	85	5	19	-	67	-	50	104	-	M 25	
32	4	101366	179	118	88	5	-	24	62	35	60	-	108	8 - 22	
		101354, 101360, 101372	155	106	85	5	19	-	67	-	50	104	-	M 25	
32	5	101367	181	122	89	5	-	24	62	35	60	-	108	8 - 22	
		101355, 101361, 101373	157	111	85	5	19	-	67	-	50	104	-	M 25	

R - sealing range

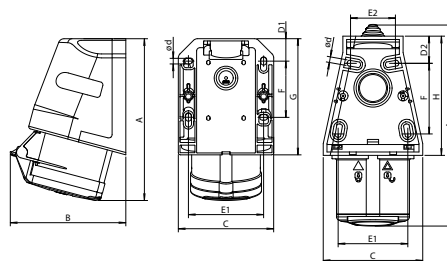

Wall sockets IP44 - 16 A/32 A Loop

Amp	Poles	Ord. No.	Dimensions (mm)								
			A	B	C	Ød	D1	E1	F	G	R
16	3	101440, 101446	175	127	80	5,5	16	68	67,5	125	3x M 25 Ø 20
16	4	101447, 101453	176	130	80	5,5	16	68	67,5	125	3x M 25 Ø 20
16	5	101448, 101454	176	133	80	5,5	16	68	67,5	125	3x M 25 Ø 20
32	3	101443, 101449	188	136	80	5,5	16	68	67,5	125	3x M 25 Ø 20
32	4	101450, 101456	188	136	80	5,5	16	68	67,5	125	3x M 25 Ø 20
32	5	101451, 101457	188	141	80	5,5	16	68	67,5	125	3x M 25 Ø 20

R - sealing range

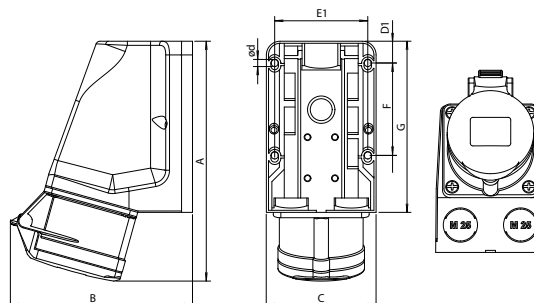

Wall sockets IP44 - 63 A

- Screw contacts.
- Flexible/rigid conductors 6 - 16/6 - 25 mm².



101477

Complies with standards: IEC 60309-1, -2
STN EN 60309-1, -2
Material: PA6, ABS
Surface treatment contacts: nickel-plated brass
Operating temperature: -25 °C to +55 °C

Amp.	Poles	110 V~ 50/60 Hz	230 V~ 50/60 Hz	400 V~ 50/60 Hz	500 V~ 50/60 Hz	Pkg. (pcs.)
		4h	3p=6h 4p+5p=9h	3p=9h 4p+5p=6h	7h	
63	3		101473 (IZN 6332)			- / 2/ - / -
63	4			101477 (IZ 6343)	101480 (IZ 6345)	- / - / 2/2
63	5			101478 (IZN 6353)		- / - / 2/-

Wall sockets - Screwless IP44 - 16 A/32 A

- Screwless contacts.
- 16 A - flexible/rigid conductors 1 - 2,5/1 - 4 mm².
- 32 A - flexible/rigid conductors 2,5 - 6/2,5 - 10 mm².



101544

Complies with standards: IEC 60309-1, -2
STN EN 60309-1, -2
Material: PA6, ABS
Surface treatment contacts: passivated brass
Operating temperature: -25 °C to +55 °C

Amp.	Poles	110 V~ 50/60 Hz	230 V~ 50/60 Hz	400 V~ 50/60 Hz	500 V~ 50/60 Hz	Pkg. (pcs.)
		4h	3p=6h 4p+5p=9h	3p=9h 4p+5p=6h	7h	
16	3	101530 (IZB 1631)	101536 (IZB 1632)			10/10/ - / -
16	4	101531 (IZB 1641)	101537 (IZB 1642)	101543 (IZB 1643)		10/10/10/-
16	5	101532 (IZB 1651)	101538 (IZB 1652)	101544 (IZB 1653)		10/10/10 / -
32	3	101533 (IZB 3231)	101539 (IZB 3232)			10/10/ - / -
32	4	101534 (IZB 3241)	101540 (IZB 3242)	101546 (IZB 3243)		10/10/10/-
32	5	101535 (IZB 3251)	101541 (IZB 3252)	101547 (IZB 3253)		10/10/10 / -

Wall sockets IP67 - 16 A/32 A

- Screw contacts.
- 16 A - flexible/rigid conductors 1 - 2,5/1 - 4 mm².
- 32 A - flexible/rigid conductors 2,5 - 6/2,5 - 10 mm².



101634

Complies with standards: IEC 60309-1, -2
STN EN 60309-1, -2
Material: PA6, ABS
Surface treatment contacts: passivated brass
Operating temperature: -25 °C to +55 °C

Amp.	Poles	110 V~ 50/60 Hz	230 V~ 50/60 Hz	400 V~ 50/60 Hz	500 V~ 50/60 Hz	Pkg. (pcs.)
		4h	3p=6h 4p+5p=9h	3p=9h 4p+5p=6h	7h	
16	3	101620 (IZG 1631)	101626 (IZG 1632)	101632 (IZG 1633)	101638 (IZG 1635)	5 / 5 / 5 / 5
16	4	101621 (IZG 1641)	101627 (IZG 1642)	101633 (IZG 1643)	101639 (IZG 1645)	5 / 5 / 5 / 5
16	5	101622 (IZG 1651)		101634 (IZG 1653)	101640 (IZG 1655)	5 / - / 5 / 5
32	3	101623 (IZG 3231)	101629 (IZG 3232)	101635 (IZG 3233)	101641 (IZG 3235)	5 / 5 / 5 / 5
32	4	101624 (IZG 3241)	101630 (IZG 3242)	101636 (IZG 3243)	101642 (IZG 3245)	5 / 5 / 5 / 5
32	5	101625 (IZG 3251)		101637 (IZG 3253)	101643 (IZG 3255)	5 / - / 5 / 5

Products may differ from the illustration.



Wall sockets IP44 - 63 A

Amp	Poles	Ord. No.	Dimensions (mm)											
			A	B	C	Ød	D1	D2	E1	E2	F	G	H	R
63	3	101473	261	190	118	6,2	-	24,5	-	104	136	-	185	M 40
63	4	101477, 101480	264	132	132	7	90	-	114	-	-	181	-	23 - 36
63	5	101478	261	190	118	6,2	-	24,5	-	104	136	-	185	M 40

R - sealing range

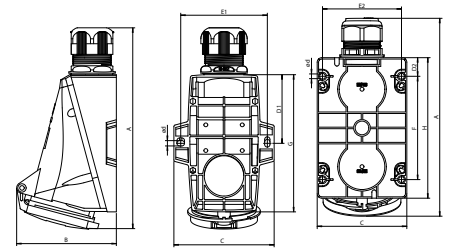

Wall sockets - Screwless IP44 - 16 A/32 A

Amp	Poles	Ord. No.	Dimensions (mm)											
			A	B	C	Ød	D1	D2	E1	E2	F	G	H	R
16	3	101530, 101536	142	97	85	5	19	-	67	-	50	104	-	M 25
16	4	101531, 101537, 101543	145	98	85	5	19	-	67	-	50	104	-	M 25
16	5	101544	158	104	78	5	-	18	53	30	58	-	96	8 - 22
		101532, 101538	144	104	85	5	19	-	67	-	50	104	-	M 25
32	3	10533, 101539	155	106	85	5	19	-	67	-	50	104	-	M 25
32	4	101534, 101540, 101546	155	106	85	5	19	-	67	-	50	104	-	M 25
32	5	101547	181	122	89	5	-	18	62	35	60	-	108	8 - 22
		101535, 101541	157	111	85	5	19	-	67	-	50	104	-	M 25

R - sealing range

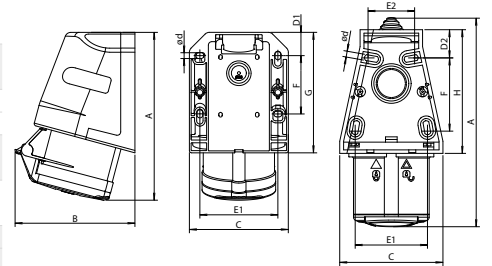

Wall sockets IP67 - 16 A/32 A

Amp	Poles	Ord. No.	Dimensions (mm)											
			A	B	C	Ød	D1	D2	E1	F	G	H	R	
16	3	101626	178	90	79	4,8	32	-	66	-	125	-	8 - 16	
		101620, 101632, 101638	146	96	80	5	-	15	70	47	-	103	M 25	
16	4	101633	180	92	79	4,8	32	-	66	-	125	-	8 - 16	
		101621, 101627, 10139	148	99	80	5	-	15	70	47	-	103	M 25	
16	5	101634	180	96	87	4,8	32	-	66	-	125	-	8 - 16	
		101622, 101640	148	102	80	5	-	15	70	47	-	103	M 25	
32	3	101629	201	111	93	5,2	35	-	71	-	145	-	11-18	
		101623, 101635, 101641	161	108	80	5	-	15	70	47	-	103	M 25	
32	4	101636	201	111	93	5,2	35	-	71	-	145	-	11-18	
		101624, 101630, 101642	161	108	80	5	-	15	70	47	-	103	M 25	
32	5	101637	203	114	100	5,2	35	-	71	-	145	-	11-18	
		101625, 101643	163	112	80	5	-	15	70	47	-	103	M 25	

R - sealing range

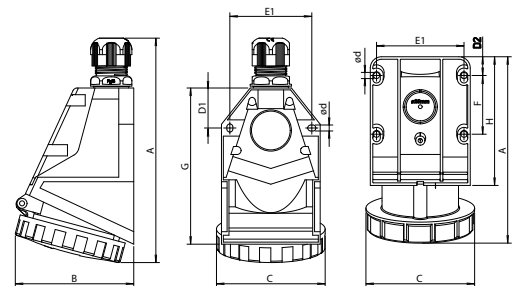

Wall sockets IP67 - 16 A/32 A Loop

- Screw contacts.
- 16 A - flexible/rigid conductors 1 - 2,5/1 - 4 mm².
- 32 A - flexible/rigid conductors 2,5 - 6/2,5 - 10 mm².
- Loop - raised socket base for looping. (standard)
- Loop ready - added 5-pole terminal block not connected. (on request)
- Loop complete - added 5-pole connected terminal block. (on request)



101724

Complies with standards:	IEC 60309-1, -2 STN EN 60309-1, -2
Material:	PA6, ABS
Surface treatment contacts:	passivated brass
Operating temperature:	-25 °C to +55 °C

Amp.	Poles	Ord. No. (Type)				Pkg. (pcs.)
		110 V~ 50/60 Hz 4h	230 V~ 50/60 Hz 3p=6h 4p+5p=9h	400 V~ 50/60 Hz 3p=9h 4p+5p=6h	500 V~ 50/60 Hz 7h	
16	3	101710 (IZG 1631 L)	101716 (IZG 1632 L)			10/10/ -/-
16	4		101717 (IZG 1642 L)	101723 (IZG 1643 L)		-/ 10/10/-
16	5			101724 (IZG 1653 L)		-/ -/ 10/-
32	3	101713 (IZG 3231 L)	101719 (IZG 3232 L)			10/10/ -/-
32	4		101720 (IZG 3242 L)	101726 (IZG 3243 L)		-/ 10/10/-
32	5			101727 (IZG 3253 L)		-/ -/ 10/-

Wall sockets - Screwless IP67 - 16 A/32 A

- Screwless contacts.
- 16 A - flexible/rigid conductors 1 - 2,5/1 - 4 mm².
- 32 A - flexible/rigid conductors 2,5 - 6/2,5 - 10 mm².



101814

Complies with standards:	IEC 60309-1, -2 STN EN 60309-1, -2
Material:	PA6, ABS
Surface treatment contacts:	passivated brass
Operating temperature:	-25 °C to +55 °C

Amp.	Poles	Ord. No. (Type)				Pkg. (pcs.)
		110 V~ 50/60 Hz 4h	230 V~ 50/60 Hz 3p=6h 4p+5p=9h	400 V~ 50/60 Hz 3p=9h 4p+5p=6h	500 V~ 50/60 Hz 7h	
16	3	101800 (IZGB 1631)	101806 (IZGB 1632)			5/ 5/ -/-
16	4	101801 (IZGB 1641)	101807 (IZGB 1642)	101813 (IZGB 1643)		5/ 5/ 5/-
16	5	101802 (IZGB 1651)	101808 (IZGB 1652)	101814 (IZGB 1653)		5/ 5/ 5/-
32	3	101803 (IZGB 3231)	101809 (IZGB 3232)			5/ 5/ -/-
32	4	101804 (IZGB 3241)	101810 (IZGB 3242)	101816 (IZGB 3243)		5/ 5/ 5/-
32	5	101805 (IZGB 3251)	101811 (IZGB 3252)	101817 (IZGB 3253)		5/ 5/ 5/-

Wall sockets IP67 - 63 A

- Screw contacts.
- Flexible/rigid conductors 6 - 16/6 - 25 mm².



101898

Complies with standards:	IEC 60309-1, -2 STN EN 60309-1, -2
Material:	PA6, ABS
Surface treatment contacts:	nickel-plated brass
Operating temperature:	-25 °C to +55 °C

Amp.	Poles	Ord. No. (Type)				Pkg. (pcs.)
		110 V~ 50/60 Hz 4h	230 V~ 50/60 Hz 3p=6h 4p+5p=9h	400 V~ 50/60 Hz 3p=9h 4p+5p=6h	500 V~ 50/60 Hz 7h	
63	4			101897 (IZG 6343)	101900 (IZG 6345)	-/ -/ 2/2
63	5			101898 (IZGN 6353)		-/ -/ 2/-

Products may differ from the illustration.



Wall sockets IP67 - 16 A/32 A Loop

Amp	Poles	Ord. No.	Dimensions (mm)										R1/R2
			A	B	C	Ø d	D	D1	E1	F	G		
16	3	101710, 101716	132	110	94	5,2	-	48	80	-	96	1x M 20 1x M 20	
16	4	101717, 101723	146	134	109	5,2	31	-	97	51	113	1x M 20 2x M 25	
16	5	101724	150	134	109	5,2	31	-	97	51	113	1x M 25 2x M 25	
32	3	101713, 101719	166	151	127	5,2	33	-	113	65	131	1x M 32 2x M 32	
32	4	101720, 101726	166	151	127	5,2	33	-	113	65	131	1x M 32 2x M 32	
32	5	101727	169	152	131	5,2	33	-	113	65	131	1x M 32 2x M 32	

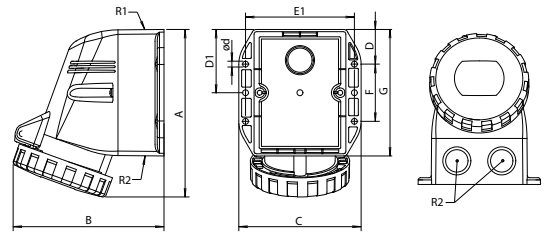

R1/R2 - sealing range

Wall sockets - Screwless IP67 - 16 A/32 A

Amp	Poles	Ord. No.	Dimensions (mm)									
			A	B	C	Ø d	D2	E1	F	H	R	
16	3	101800, 101806	146	96	80	5	15	70	47	103	M 25	
16	4	101801, 101807, 101813	148	99	80	5	15	70	47	103	M 25	
16	5	101802, 101808, 101814	148	102	80	5	15	70	47	103	M 25	
32	3	101803, 101809	161	108	80	5	15	70	47	103	M 25	
32	4	101804, 101810, 101816	161	108	80	5	15	70	47	103	M 25	
32	5	101805, 101811, 101817	163	112	80	5	15	70	47	103	M 25	

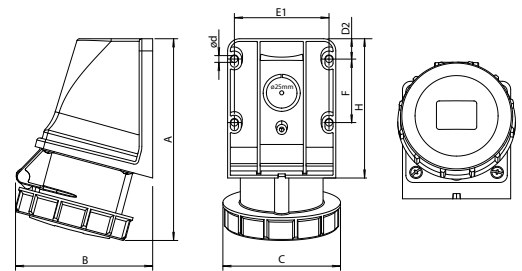

R - sealing range

Wall sockets IP67 - 63 A

Amp	Poles	Ord. No.	Dimensions (mm)												
			A	B	C	Ø d	D1	D2	E1	E2	F	G	H	R	
63	4	101897, 101900	267	131	132	7	-	90	114	-	-	-	181	23 - 36	
63	5	101898	339	145	140	6,5	14	-	125	90	155	187	-	23 - 36	

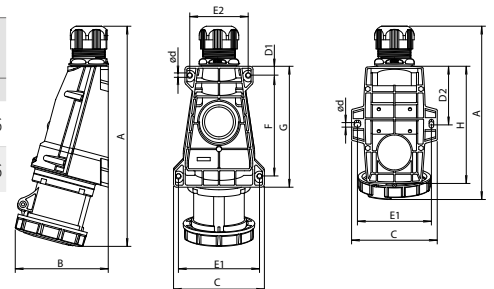

R - sealing range

Wall sockets IP67 - 63 A Loop

- Screw contacts.
- Flexible/rigid conductors 6 - 16/6 - 25 mm².
- Loop - raised socket base for looping. (standard)
- Loop ready - added 5-pole terminal block not connected. (on request)
- Loop complete - added 5-pole connected terminal block. (on request)



101978

Complies with standards:	IEC 60309-1, -2 STN EN 60309-1, -2
Material:	PA6, ABS
Surface treatment contacts:	nickel-plated brass
Operating temperature:	-25 °C to +55 °C

Amp.	Poles	110 V~ 50/60 Hz	230 V~ 50/60 Hz	400 V~ 50/60 Hz	500 V~ 50/60 Hz	Pkg. (pcs.)
		4h	3p=6h 4p+5p=9h	3p=9h 4p+5p=6h	7h	
63	3	101970 (IZGN 6331 L)	101973 (IZGN 6332 L)			1 / 1 / - / -
63	4	101971 (IZGN 6341)		101977 (IZGN 6343 L)		1 / - / 4 / -
63	5	101972 (IZGN 6351 L)		101978 (IZGN 6353 L)		1 / - / 4 / -

Wall sockets IP67 - 125 A

- Screw contacts.
- Flexible/rigid conductors 16 - 50/16 - 70 mm².



102070

Complies with standards:	IEC 60309-1, -2 STN EN 60309-1, -2
Material:	PA6, ABS
Surface treatment contacts:	nickel-plated brass
Operating temperature:	-25 °C to +55 °C

Amp.	Poles	110 V~ 50/60 Hz	230 V~ 50/60 Hz	400 V~ 50/60 Hz	500 V~ 50/60 Hz	Pkg. (pcs.)
		4h	3p=6h 4p+5p=9h	3p=9h 4p+5p=6h	7h	
125	3	102050 (IZGN 12531)	102059 (IZGN 12532)			1 / 1 / - / -
125	4	102051 (IZGN 12541)		102069 (IZGN 12543)	102078 (IZGN 12545)	1 / - / 1 / 1
125	5	102052 (IZGN 12551)		102070 (IZGN 12553)	102079 (IZGN 12555)	1 / - / 1 / 1

With pilot contact

125	3	102053 (IZGN 12531-p)	102062 (IZGN 12532-p)			1 / 1 / - / -
125	4	102054 (IZGN 12541-p)		102072 (IZGN 12543-p)	102081 (IZGN 12545-p)	1 / - / 1 / 1
125	5	102055 (IZGN 12551-p)		102073 (IZGN 12553-p)	102082 (IZGN 12555-p)	1 / - / 1 / 1

Wall sockets-Combined French IP44 - 250 V/400 V

- Screw contacts.
- 32 A sockets contain a 10 A tube fuse.
- Ord. No. 102150 has a 3P/230 V/16 A indust. socket, 102153 has a 3P/230 V/32 A indust. socket.
- 16 A - flexible/rigid conductors 1 - 2,5/1 - 4 mm².
- 32 A - flexible/rigid conductors 2,5 - 6/2,5 - 10 mm².



102158

Complies with standards:	IEC 60309-1, -2 STN EN 60309-1, -2
Material:	PA6, ABS
Surface treatment contacts:	passivated brass
Operating temperature:	-25 °C to +55 °C

Amp.	Poles	110 V~ 50/60 Hz	230 V~ 50/60 Hz	400 V~ 50/60 Hz	500 V~ 50/60 Hz	Pkg. (pcs.)
		4h	3p=6h 4p+5p=9h	3p=9h 4p+5p=6h	7h	
16	3		102150 (IZVZ 1632)			- / 5 / - / -
16	4			102157 (IZVZ 1643)		- / - / 5 / -
16	5			102158 (IZVZ 1653)		- / - / 5 / -
32	3		102153 (IZVZ 3232)			- / 5 / - / -
32	4			102160 (IZVZ 3243)		- / - / 5 / -
32	5			102161 (IZVZ 3253)		- / - / 5 / -

Products may differ from the illustration.

Wall sockets IP67 - 63 A Loop

Amp	Poles	Ord. No.	Dimensions (mm)									R
			A	B	C	Ød	D	E1	F	G		
63	3	101970, 101973	213	173	118	6	18	104	136	170	M 40 2 x M 32	
63	4	101971, 101977	213	173	118	6	18	104	136	170	M 40 2 x M 32	
63	5	101972, 101978	213	173	118	6	18	104	136	170	M 40 2 x M 32	

R - sealing range

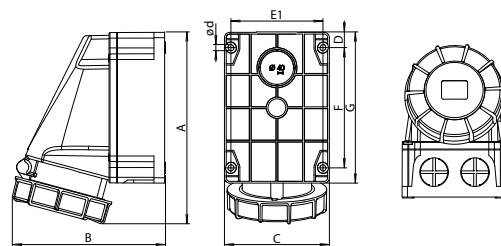

Wall sockets IP67 - 125 A

Amp	Poles	Ord. No.	Dimensions (mm)									R
			A	B	C	Ød	D	E1	F	G		
125	3	102050, 102059	322	205	162	8	11	140	240	262	M 63 2 x Ø 40	
125	4	102051, 102069, 102078	322	205	162	8	11	140	240	262	M 63 2 x Ø 40	
125	5	102052, 102070, 102079	322	205	162	8	11	140	240	262	M 63 2 x Ø 40	
With pilot contact												
125	3	102053, 102062	322	205	162	8	11	140	240	262	M 63 2 x Ø 40	
125	4	102054, 102072, 102081	322	205	162	8	11	140	240	262	M 63 2 x Ø 40	
125	5	102055, 102073, 102082	322	205	162	8	11	140	240	262	M 63 2 x Ø 40	

R - sealing range

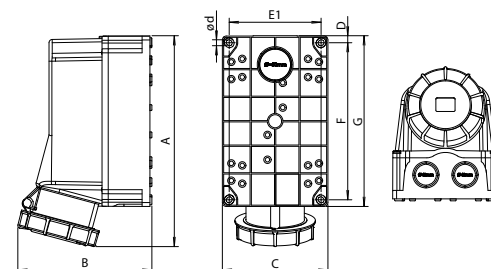

Wall sockets-Combined French IP44 - 250 V/400 V

Amp	Poles	Ord. No.	Dimensions (mm)								R
			A	B	C	D	F	E1	E2		
16	3	102150	182	113	90	71	67	45	55	8 - 22	
16	4	102157	182	113	90	71	67	45	55	8 - 22	
16	5	102158	182	113	90	71	67	45	55	8 - 22	
32	3	102153	193	118	90	71	67	45	55	8 - 22	
32	4	102160	193	118	90	71	67	45	55	8 - 22	
32	5	102161	193	118	90	71	67	45	55	8 - 22	

R - sealing range

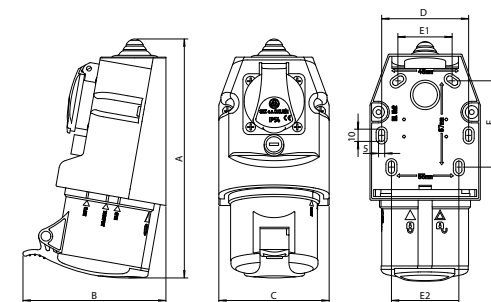

Wall sockets-Combined Schuko IP 44 - 250 V/400 V

- Screw contacts.
- 32 A sockets contain a 10 A tube fuse.
- Ord. No. 102200 has a 3P/230 V/16 A indust. socket, 102203 has a 3P/230 V/32 A indust. socket.
- 16 A - flexible/rigid conductors 1 - 2,5/1 - 4 mm².
- 32 A - flexible/rigid conductors 2,5 - 6/2,5 - 10 mm².



102208

Complies with standards: IEC 60309-1, -2
STN EN 60309-1, -2
Material: PA6, ABS
Surface treatment contacts: passivated brass
Operating temperature: -25 °C to +55 °C

Amp.	Poles	110 V~ 50/60 Hz	230 V~ 50/60 Hz	400 V~ 50/60 Hz	500 V~ 50/60 Hz	Pkg. (pcs.)
		4h	3p=6h 4p+5p=9h	3p=9h 4p+5p=6h	7h	
		Ord. No. (Type)				
16	3		102200 (IZVZ-S 1632)			- / 5 / - / -
16	4			102207 (IZVZ-S 1643)		- / - / 5 / -
16	5			102208 (IZVZ-S 1653)		- / - / 5 / -
32	3		102203 (IZVZ-S 3232)			- / 5 / - / -
32	4			102210 (IZVZ-S 3243)		- / - / 5 / -
32	5			102211 (IZVZ-S 3253)		- / - / 5 / -

Wall sockets with box under plaster - IP44

- Screw contacts.
- 16 A - flexible/rigid conductors 1 - 2,5/1 - 4 mm².
- 32 A - flexible/rigid conductors 2,5 - 6/2,5 - 10 mm².
- Ord. No. 102257 has a 3P/250 V/16 A house socket, 102258 has a 3P/250 V/16 A house socket - Schuko.
- Ord. No. 102262 has a 3P/230 V/32 A indust. socket.



102268

Complies with standards: IEC 60309-1, -2
STN EN 60309-1, -2
Material: PA6, ABS
Surface treatment contacts: passivated brass
Operating temperature: -25 °C to +55 °C

Amp.	Poles	110 V~ 50/60 Hz	250 V~ (230 V~) 50/60 Hz	400 V~ 50/60 Hz	500 V~ 50/60 Hz	Pkg. (pcs.)
		4h	3p=6h 4p+5p=9h	3p=9h 4p+5p=6h	7h	
		Ord. No. (Type)				
16	3 house		102257, 102258 (IZV 16, 16S)			- / 2 / - / -
16	4			102267 (IZV 1643)		- / - / 2 / -
16	5			102268 (IZV 1653)		- / - / 2 / -
32	3 industrial		102262 (IZV 3232)			- / 2 / - / -
32	4			102270 (IZV 3243)		- / - / 2 / -
32	5			102271 (IZV 3253)		- / - / 2 / -

Wall sockets with box - IP44

- Screw contacts.
- 16 A - flexible/rigid conductors 1 - 2,5/1 - 4 mm².
- 32 A - flexible/rigid conductors 2,5 - 6/2,5 - 10 mm².
- Ord. No. 102347 has a 3P/250 V/16 A house socket, 102348 has a 3P/250 V/16 A house socket - Schuko.
- Ord. No. 102352 has a 3P/230 V/32 A indust. socket.



102347

Complies with standards: IEC 60309-1, -2
STN EN 60309-1, -2
Material: PA6, ABS
Surface treatment contacts: passivated brass
Operating temperature: -25 °C to +55 °C

Amp.	Poles	110 V~ 50/60 Hz	250 V~ (230 V~) 50/60 Hz	400 V~ 50/60 Hz	500 V~ 50/60 Hz	Pkg. (pcs.)
		4h	3p=6h 4p+5p=9h	3p=9h 4p+5p=6h	7h	
		Ord. No. (Type)				
16	3 house		102347, 102348 (IZVN 16, 16S)			- / 2 / - / -
16	4			102357 (IZVN 1643)		- / - / 2 / -
16	5			102358 (IZVN 1653)		- / - / 2 / -
32	3 industrial		102352 (IZVN 3232)			- / 2 / - / -
32	4			102360 (IZVN 3243)		- / - / 2 / -
32	5			102361 (IZVN 3253)		- / - / 2 / -

Products may differ from the illustration.



Wall sockets-Combined Schuko IP44 - 250 V/400 V - Schuko

Amp	Poles	Ord. No.	Dimensions (mm)							
			A	B	C	D	F	E1	E2	R
16	3	102200	182	113	90	71	67	45	55	8 - 22
16	4	102207	182	113	90	71	67	45	55	8 - 22
16	5	102208	182	113	90	71	67	45	55	8 - 22
32	3	102203	193	118	90	71	67	45	55	8 - 22
32	4	102210	193	118	90	71	67	45	55	8 - 22
32	5	102211	193	118	90	71	67	45	55	8 - 22

R - sealing range

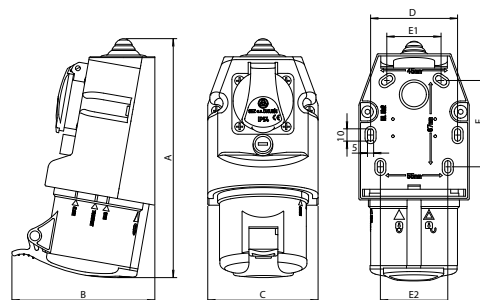

Wall sockets with box under plaster - IP44

Amp	Poles	Ord. No.	Dimensions (mm)						
			A	B	C	D	E	F	G
16	3 house	102257, 102258	112	90	93	38	74	80	30
16	3 industrial	102259	112	90	93	38	74	80	30
16	4	102267	112	90	93	38	74	80	30
16	5	102268	112	90	93	38	74	80	30
32	3 industrial	102262	112	90	93	38	74	80	30
32	4	102270	112	90	93	38	74	80	30
32	5	102271	112	90	93	38	74	80	30

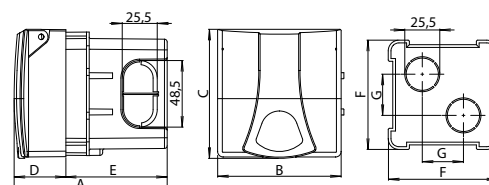

Wall sockets with box - IP44

Amp	Poles	Ord. No.	Dimensions (mm)							
			A	B	C	D	E1	E2	F	R
16	3 house	102347, 102348	106	90	93	108	71	75	67	8 - 22
16	3 industrial	102349	106	90	93	108	71	75	67	8 - 22
16	4	102357	106	90	93	108	71	75	67	8 - 22
16	5	102358	106	90	93	108	71	75	67	8 - 22
32	3 industrial	102352	106	90	93	108	71	75	67	8 - 22
32	4	102360	106	90	93	108	71	75	67	8 - 22
32	5	102361	106	90	93	108	71	75	67	8 - 22

R - sealing range

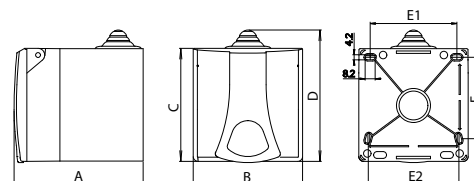

Wall inlets IP44 - 16 A/32 A

- Screw contacts.
- 16 A - flexible/rigid conductors 1 - 2,5/1 - 4 mm².
- 32 A - flexible/rigid conductors 2,5 - 6/2,5 - 10 mm².



102444

Complies with standards:	IEC 60309-1, -2 STN EN 60309-1, -2
Material:	PA6, ABS
Surface treatment contacts:	passivated brass
Operating temperature:	-25 °C to +55 °C

Amp.	Poles	110 V~ 50/60 Hz	230 V~ 50/60 Hz	400 V~ 50/60 Hz	500 V~ 50/60 Hz	Pkg. (pcs.)
		4h	3p=6h 4p+5p=9h	3p=9h 4p+5p=6h	7h	
16	3	102430 (IPN 1631)	102436 (IPN 1632)		102448 (IPN 1635)	10/ 2/ - / 10
16	4	102431 (IPN 1641)		102443 (IPN 1643)	102449 (IPN 1645)	10/ - / 2 / 10
16	5	102432 (IPN 1651)		102444 (IPN 1653)	102450 (IPN 1655)	10/ - / 2 / 10
32	3	102433 (IPN 3231)	102439 (IPN 3232)		102451 (IPN 3235)	10/ 2/ - / 10
32	4	102434 (IPN 3241)		102446 (IPN 3243)	102452 (IPN 3245)	10/ - / 2 / 10
32	5	102435 (IPN 3251)		102447 (IPN 3253)	102453 (IPN 3255)	10/ - / 2 / 10

Wall inlets - Screwless IP44 - 16 A/32 A

- Screwless contacts.
- 16 A - flexible/rigid conductors 1 - 2,5/1 - 4 mm².
- 32 A - flexible/rigid conductors 2,5 - 6/2,5 - 10 mm².



102534

Complies with standards:	IEC 60309-1, -2 STN EN 60309-1, -2
Material:	PA6, ABS
Surface treatment contacts:	passivated brass
Operating temperature:	-25 °C to +55 °C

Amp.	Poles	110 V~ 50/60 Hz	230 V~ 50/60 Hz	400 V~ 50/60 Hz	500 V~ 50/60 Hz	Pkg. (pcs.)
		4h	3p=6h 4p+5p=9h	3p=9h 4p+5p=6h	7h	
16	3	102520 (IPB 1631)	102526 (IPB 1632)			10/10/ - / -
16	5	102522 (IPB 1651)	102528 (IPB 1652)	102534 (IPB 1653)		10/10/ 2 / -
32	4	102524 (IPB 3241)	102530 (IPB 3242)			10/10/ - / -
32	5	102525 (IPB 3251)	102531 (IPB 3252)	102537 (IPB 3253)		10/10/ 2 / -

Wall inlets - Phase reverse IP44 - 16 A/32 A

- Screw contacts.
- 16 A - flexible/rigid conductors 1 - 2,5/1 - 4 mm².
- 32 A - flexible/rigid conductors 2,5 - 6/2,5 - 10 mm².
- In position can be changed by turning the screwdriver by 180 degrees to achieve the phase change.



102624

Complies with standards:	IEC 60309-1, -2 STN EN 60309-1, -2
Material:	PA6, ABS
Surface treatment contacts:	passivated brass
Operating temperature:	-25 °C to +55 °C

Amp.	Poles	110 V~ 50/60 Hz	230 V~ 50/60 Hz	400 V~ 50/60 Hz	500 V~ 50/60 Hz	Pkg. (pcs.)
		4h	3p=6h 4p+5p=9h	3p=9h 4p+5p=6h	7h	
16	5			102624 (IPNO 1653)		- / - / 2 / -
32	5			102627 (IPNO 3253)		- / - / 2 / -

Products may differ from the illustration.



Wall inlets IP44 - 16 A/32 A

Amp	Poles	Ord. No.	Dimensions (mm)											
			A	B	C	Ød	D1	D2	E1	E2	F	G	H	R
16	3	102436	147	81	78	5	-	18	53	30	58	-	96	8-22
		102430, 102448	120	76	70,5	5	12	-	58	-	33	86	-	M 25
16	4	102443	146	81	78	5	-	18	53	30	58	-	96	8-22
		102430, 102448	121	76	70,5	5	12	-	58	-	33	86	-	M 25
16	5	102444	146	81	78	5	-	18	53	30	58	-	96	8-22
		102432, 102450	122	79	70,5	5	12	-	58	-	33	86	-	M 25
32	3	102439	168	95	88	5	-	24	61	35	60	-	108	8-22
		102433, 102451	131	92	70,5	5	12	-	58	-	33	86	-	M 25
32	4	102446	168	95	88	5	-	24	61	35	60	-	108	8-22
		102434, 102452	131	92	70,5	5	12	-	58	-	33	86	-	M 25
32	5	102447	169	94	88	5	-	24	62	40	63	-	108	8-22
		102435, 102453	132	95	70,5	5	12	-	58	-	33	86	-	M 25

R - sealing range

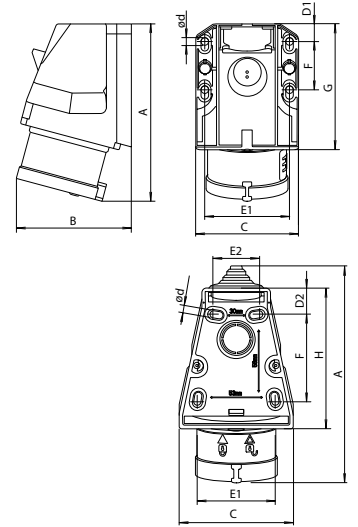

Wall inlets - Screwless IP44 - 16 A/32 A

Amp	Poles	Ord. No.	Dimensions (mm)											
			A	B	C	Ød	D1	D2	E1	E2	F	G	H	R
16	3	102520, 102526	120	76	70,5	5	12	-	58	-	33	86	-	M 25
		102534	146	81	78	5	-	18	53	30	58	-	96	8-22
16	5	102522, 102528	122	79	70,5	5	12	-	58	-	33	86	-	M 25
		102524, 102530	131	92	70,5	5	12	-	58	-	33	86	-	M 25
32	5	102537	169	94	88	5	-	24	62	40	63	-	108	8-22
		102525, 102531	132	95	70,5	5	12	-	58	-	33	86	-	M 25

R - sealing range

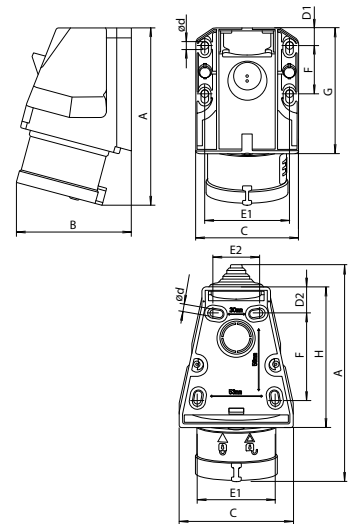

Wall inlets - Phase reverse IP44 - 16 A/32 A

Amp	Poles	Ord. No.	Dimensions (mm)									
			A	B	C	Ød	D1	E1	E2	F	G	R
16	5	102624	146	81	78	5	18	53	30	58	96	8-22
32	5	102627	169	94	88	5	24	62	40	63	108	8-22

R - sealing range

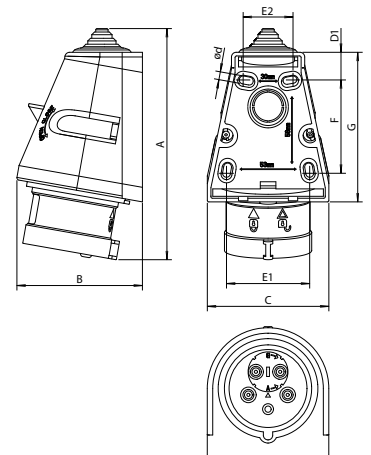

Wall inlets IP67 - 16 A/32 A

- Screw contacts.
- 16 A - flexible/rigid conductors 1 - 2,5/1 - 4 mm².
- 32 A - flexible/rigid conductors 2,5 - 6/2,5 - 10 mm².



102714

Complies with standards: IEC 60309-1, -2
STN EN 60309-1, -2
Material: PA6, ABS
Surface treatment contacts: passivated brass
Operating temperature: -25 °C to +55 °C

Amp.	Poles	110 V~ 50/60 Hz				230 V~ 50/60 Hz				400 V~ 50/60 Hz				500 V~ 50/60 Hz				Pkg. (pcs.)
		4h				3p=6h 4p+5p=9h				3p=9h 4p+5p=6h				7h				
		Ord. No. (Type)																
16	3	102700 (IPG 1631)				102706 (IPG 1632)								102718 (IPG 1635)				5 / 2 / - / 5
16	4	102701 (IPG 1641)								102713 (IPG 1643)				102719 (IPG 1645)				5 / - / 2 / 5
16	5	102702 (IPG 1651)								102714 (IPG 1653)				102720 (IPG 1655)				5 / - / 2 / 5
32	3	102703 (IPG 3231)				102709 (IPG 3232)								102721 (IPG 3235)				5 / 2 / - / 5
32	4	102704 (IPG 3241)								102716 (IPG 3243)				102722 (IPG 3245)				5 / - / 2 / 5
32	5	102705 (IPG 3251)								102717 (IPG 3253)				102723 (IPG 3255)				5 / - / 2 / 5

Wall inlets IP67 - 63 A

- Screw contacts.
- Flexible/rigid conductors 6 - 16/6 - 25 mm².



102798

Complies with standards: IEC 60309-1, -2
STN EN 60309-1, -2
Material: PA6, ABS
Surface treatment contacts: nickel-plated brass
Operating temperature: -25 °C to +55 °C

Amp.	Poles	110 V~ 50/60 Hz				230 V~ 50/60 Hz				400 V~ 50/60 Hz				500 V~ 50/60 Hz				Pkg. (pcs.)
		4h				3p=6h 4p+5p=9h				3p=9h 4p+5p=6h				7h				
		Ord. No. (Type)																
63	4									102797 (IPG 6343)				102800 (IPG 6345)				- / - / 2 / 2
63	5									102798 (IPGN 6353)								- / - / 2 / -

Wall inlets IP67 - 63 A

- Screw contacts.
- Flexible/rigid conductors 6 - 16/6 - 25 mm².



102823

Complies with standards: IEC 60309-1, -2
STN EN 60309-1, -2
Material: PA6, ABS
Surface treatment contacts: nickel-plated brass
Operating temperature: -25 °C to +55 °C

Amp.	Poles	110 V~ 50/60 Hz				230 V~ 50/60 Hz				400 V~ 50/60 Hz				500 V~ 50/60 Hz				Pkg. (pcs.)
		4h				3p=6h 4p+5p=9h				3p=9h 4p+5p=6h				7h				
		Ord. No. (Type)																
63	3	102820 (IPGN 6331)				102823 (IPGN 6332)												1 / 1 / - / -
63	4	102821 (IPGN 6341)																1 / - / - / -
63	5	102822 (IPGN 6351)																1 / - / - / -

Products may differ from the illustration.



Wall inlets IP67 - 16 A/32 A

Amp	Poles	Ord. No.	Dimensions (mm)										
			A	B	C	Ød	D1	D2	E1	F	G	H	R
16	3	102706	149	82	70	4,8	15	-	45	30	60	-	8-16
		102700, 102718	136	99	71	5	-	15	70	47	-	103	M 25
16	4	102713	152	93	78	5,2	17,5	-	50	30	65	-	8 - 16
		102701, 102719	138	94	79	5	-	15	70	47	-	103	M 25
16	5	102714	152	97	87	5,2	17,5	-	50	30	65	-	8 - 16
		102702, 102720	140	100	87	5	-	15	70	47	-	103	M 25
32	3	102709	174	109	93	5,2	20	-	58	40	80	-	11-18
		102703, 102721	150	104	93	5	-	15	70	47	-	103	M 25
32	4	102716	174	109	93	5,2	20	-	58	40	80	-	11 - 18
		102704, 102722	153	104	93	5	-	15	70	47	-	103	M 25
32	5	102717	174	113	100	5,2	20	-	58	40	80	-	11 - 18
		102705, 102723	152	102	102	5	-	15	70	47	-	103	M 25

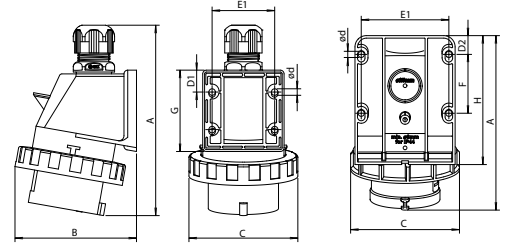

R - sealing range

Wall inlets IP67 - 63 A

Amp	Poles	Ord. No.	Dimensions (mm)											
			A	B	C	Ød	D1	D2	E1	E2	F	G	H	R
63	4	102797, 102800	295	122	112	6	-	72	92	-	-	-	144	14 - 26
63	5	102798	322	130	140	6,5	13,5	-	125	90	155	186	-	23 - 36

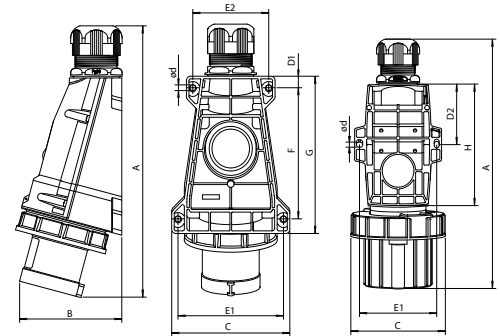

R - sealing range

Wall inlets IP67 - 63 A

Amp	Poles	Ord. No.	Dimensions (mm)										
			A	B	C	Ød	D	E1	F	G	R		
63	3	102820, 102823	271	175	118	6	18	104	136	170	M 40 2 x M 32		
63	4	102821	271	175	118	6	18	104	136	170	M 40 2 x M 32		
63	5	102822	271	175	118	6	18	104	136	170	M 40 2 x M 32		

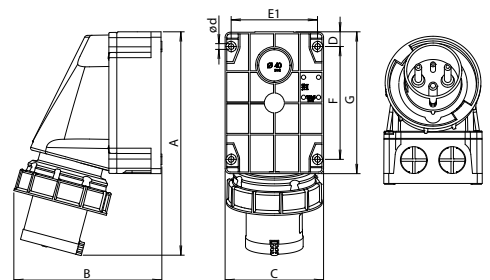

R - sealing range

Wall inlets IP67 - 125 A

- Screw contacts.
- Wall inlets also have a pilot contact.
- Flexible/rigid conductors 16 - 50/16 - 70 mm².

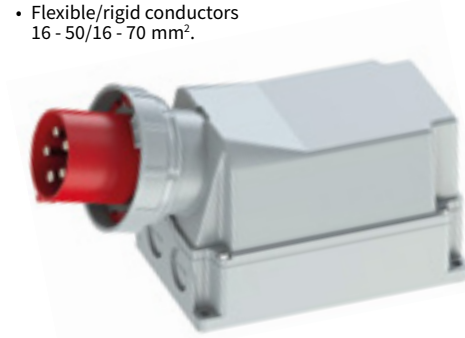

102878

Complies with standards: IEC 60309-1, -2
STN EN 60309-1, -2
Material: PA6, ABS
Surface treatment contacts: nickel-plated brass
Operating temperature: -25 °C to +55 °C

Amp.	Poles	Ord. No. (Type)				Pkg. (pcs.)
		110 V~ 50/60 Hz 4h	230 V~ 50/60 Hz 3p=6h 4p+5p=9h	400 V~ 50/60 Hz 3p=9h 4p+5p=6h	500 V~ 50/60 Hz 7h	
125	3	102870 (IPGN 12531)	102873 (IPGN 12532)			1 / 1 / - / -
125	4	102871 (IPGN 12541)		102877 (IPGN 12543)	102880 (IPGN 12545)	1 / - / 1 / 1
125	5	102872 (IPGN 12551)		102878 (IPGN 12553)	102881 (IPGN 12555)	1 / - / 1 / 1

Panel sockets angled IP44/IP54 - 16 A/32 A

- Screw contacts.
- 16 A - flexible/rigid conductors 1 - 2,5/1 - 4 mm².
- 32 A - flexible/rigid conductors 2,5 - 6/2,5 - 10 mm².
- Ord. No. 102956, 102959, 102963, 102964, 102966, 102967 have IP54 protection.



102964

Complies with standards: IEC 60309-1, -2
STN EN 60309-1, -2
Material: PA6, ABS
Surface treatment contacts: passivated brass
Operating temperature: -25 °C to +55 °C

Amp.	Poles	Ord. No. (Type)				Pkg. (pcs.)
		110 V~ 50/60 Hz 4h	230 V~ 50/60 Hz 3p=6h 4p+5p=9h	400 V~ 50/60 Hz 3p=9h 4p+5p=6h	500 V~ 50/60 Hz 7h	
16	3	102950 (IEN 1631)	102956 (IE 1632)		102968 (IEN 1635)	10/10 / - / 10
16	4	102951 (IEN 1641)	102957 (IEN 1642)	102963 (IEN 1643)	102969 (IEN 1645)	10/10/10/10
16	5	102952 (IEN 1651)	102958 (IEN 1652)	102964 (IEN 1653)	102970 (IEN 1655)	10/10/10/10
32	3	102953 (IEN 3231)	102959 (IE 3232)		102971 (IEN 3235)	10/10 / - / 10
32	4	102954 (IEN 3241)	102960 (IEN 3242)	102966 (IEN 3243)	102972 (IEN 3245)	10/10/10/10
32	5	102955 (IEN 3251)	102961 (IEN 3252)	102967 (IEN 3253)	102973 (IEN 3255)	10/10/10/10

Panel sockets angled IP44 - 63 A

- Screw contacts.
- Flexible/rigid conductors 6 - 16/6 - 25 mm².



103048

Complies with standards: IEC 60309-1, -2
STN EN 60309-1, -2
Material: PA6, ABS
Surface treatment contacts: nickel-plated brass
Operating temperature: -25 °C to +55 °C

Amp.	Poles	Ord. No. (Type)				Pkg. (pcs.)
		110 V~ 50/60 Hz 4h	230 V~ 50/60 Hz 3p=6h 4p+5p=9h	400 V~ 50/60 Hz 3p=9h 4p+5p=6h	500 V~ 50/60 Hz 7h	
63	3		103043 (IEN 6332)			- / 2 / - / -
63	4			103047 (IEN 6343)		- / - / 2 / -
63	5			103048 (IEN 6353)		- / - / 2 / -



Wall inlets IP67 - 125 A

Amp	Poles	Ord. No.	Dimensions (mm)									R
			A	B	C	ø d	D	E1	F	G		
125	3	102870, 102873	387	209	162	6	11	142	240	262	M 63 2 x M 40	
125	4	102871, 102877, 102880	387	209	162	6	11	142	240	262	M 63 2 x M 40	
125	5	102872, 102878, 102881	387	209	162	6	11	142	240	262	M 63 2 x M 40	

R - sealing range

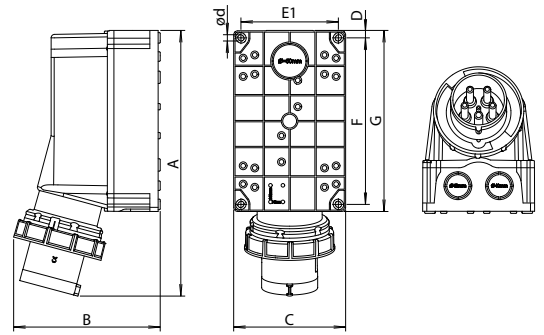

Panel sockets angled IP44/IP54 - 16 A/32 A

Amp	Poles	Ord. No.	Dimensions (mm)									
			A	B	C	Ød1	E	F	G	H	J	K
16	3	102956	97	85	75	5,5	60	60	60	56	32	29
		102950, 102968	97	97	80		73	61	51	47	38	
16	4	102963	93	85	75	5,5	60	60	66	60	42	31
		102951, 102957, 102969	103	97	80		73	67	56	47	38	
16	5	102964	97	85	75	5,5	60	60	75	65	43	32
		102952, 102958, 102970	105	97	80		73	76	65	49	38	
32	3	102959	116	95	80	5,5	60	70	80	68	42	42
		102953, 102971	105	97	80		73	75	65	54	48	
32	4	102966	108	95	80	5,5	60	70	80	68	52	38
		102954, 102960, 102972	105	97	80		73	75	65	55	48	
32	5	102967	111	95	80	5,5	60	70	85	72	52	39
		102955, 102961, 102973	99	97	80		73	80	70	55	48	

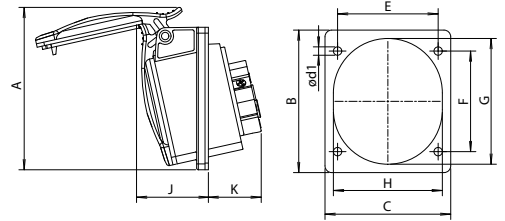

Panel sockets angled IP44 - 63 A

Amp	Poles	Ord. No.	Dimensions (mm)									
			A	B	C	ø d1	E	F	G	H	J	K
63	3	103043	132	110	106	7	90	90	92	82	74	64
63	4	103047	132	110	106	7	90	90	92	82	74	64
63	5	103048	132	110	106	7	90	90	92	82	74	64

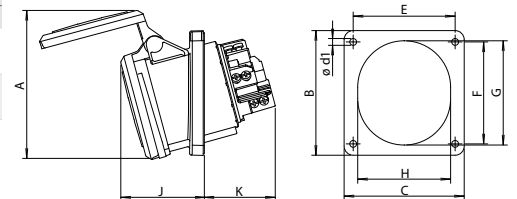

Panel sockets angled - Screwless IP44/IP54 - 16 A/32 A

- Screwless contacts.
- 16 A - flexible/rigid conductors 1 - 2,5/1 - 4 mm².
- 32 A - flexible/rigid conductors 2,5 - 6/2,5 - 10 mm².
- Ord. No. 103144, 103147 have IP54 protection.



103144

Complies with standards: IEC 60309-1, -2
STN EN 60309-1, -2
Material: PA6, ABS
Surface treatment contacts: passivated brass
Operating temperature: -25 °C to +55 °C

Amp.	Poles	Ord. No. (Type)				Pkg. (pcs.)
		110 V~ 50/60 Hz 4h	230 V~ 50/60 Hz 3p=6h 4p+5p=9h	400 V~ 50/60 Hz 3p=9h 4p+5p=6h	500 V~ 50/60 Hz 7h	
16	3	103130 (IEB 1631)	103136 (IEB 1632)			10/10/-/-
16	4	103131 (IEB 1641)	103137 (IEB 1642)	103143 (IEB 1643)		10/10/10/-
16	5	103132 (IEB 1651)	103138 (IEB 1652)	103144 (IEB 1653)		10/10/10/-
32	3	103133 (IEB 3231)	103139 (IEB 3232)			10/10/-/-
32	4	103134 (IEB 3241)	103140 (IEB 3242)	103146 (IEB 3243)		10/10/10/-
32	5	103135 (IEB 3251)	103141 (IEB 3252)	103147 (IEB 3253)		10/10/10/-

Panel sockets angled IP67 - 16 A/32 A

- Screw contacts.
- 16 A - flexible/rigid conductors 1 - 2,5/1 - 4 mm².
- 32 A - flexible/rigid conductors 2,5 - 6/2,5 - 10 mm².



103237

Complies with standards: IEC 60309-1, -2
STN EN 60309-1, -2
Material: PA6, ABS
Surface treatment contacts: passivated brass
Operating temperature: -25 °C to +55 °C

Amp.	Poles	Ord. No. (Type)				Pkg. (pcs.)
		110 V~ 50/60 Hz 4h	230 V~ 50/60 Hz 3p=6h 4p+5p=9h	400 V~ 50/60 Hz 3p=9h 4p+5p=6h	500 V~ 50/60 Hz 7h	
16	3	103220 (IEG 1631)	103226 (IEG 1632)		103238 (IEG 1635)	10/2/-/10
16	4	103221 (IEG 1641)	103227 (IEG 1642)	103233 (IEG 1643)	103239 (IEG 1645)	10/10/2/10
16	5	103222 (IEG 1651)		103234 (IEG 1653)	103240 (IEG 1655)	10/-/2/10
32	3	103223 (IEG 3231)	103229 (IEG 3232)		103241 (IEG 3235)	10/2/-/10
32	4	103224 (IEG 3241)	103230 (IEG 3242)	103236 (IEG 3243)	103242 (IEG 3245)	10/10/2/10
32	5	103225 (IEG 3251)		103237 (IEG 3253)	103243 (IEG 3255)	10/-/2/10

Panel sockets angled - Screwless IP67 - 16 A/32 A

- Screwless contacts.
- 16 A - flexible/rigid conductors 1 - 2,5/1-4 mm².
- 32 A - flexible/rigid conductors 2,5 - 6/2,5 - 10 mm².



103327

Complies with standards: IEC 60309-1, -2
STN EN 60309-1, -2
Material: PA6, ABS
Surface treatment contacts: passivated brass
Operating temperature: -25 °C to +55 °C

Amp.	Poles	Ord. No. (Type)				Pkg. (pcs.)
		110 V~ 50/60 Hz 4h	230 V~ 50/60 Hz 3p=6h 4p+5p=9h	400 V~ 50/60 Hz 3p=9h 4p+5p=6h	500 V~ 50/60 Hz 7h	
16	3	103310 (IEGB 1631)	103316 (IEGB 1632)			10/10/-/-
16	4	103311 (IEGB 1641)	103317 (IEGB 1642)	103323 (IEGB 1643)		10/10/10/-
16	5	103312 (IEGB 1651)	103318 (IEGB 1652)	103324 (IEGB 1653)		10/10/10/-
32	3	103313 (IEGB 3231)	103319 (IEGB 3232)			10/10/-/-
32	4	103314 (IEGB 3241)	103320 (IEGB 3242)	103326 (IEGB 3243)		10/10/10/-
32	5	103315 (IEGB 3251)	103321 (IEGB 3252)	103327 (IEGB 3253)		10/10/10/-



Panel sockets angled - Screwless IP44/IP54 - 16 A/32 A

Amp	Poles	Ord. No.	Dimensions (mm)									
			A	B	C	Ød1	E	F	G	H	J	K
16	3	103130, 103136	97	97	80	5,5	60	73	61	51	47	41
16	4	103131, 103137, 103143	103	97	80	5,5	60	73	67	56	47	41
16	5	103144	97	85	75	5,5	60	60	75	65	42	38
		103132, 103138	105	97	80			73	76	65	49	41
32	3	103133, 103139	105	97	80	5,5	60	73	75	65	54	48
32	4	103134, 103140, 103146	105	97	80	5,5	60	73	75	65	54	48
32	5	103147	111	95	80	5,5	60	70	85	72	52	55
		103135, 103141	99	97	80			73	80	70	55	48

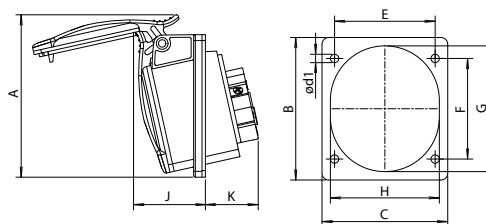

Panel sockets angled IP67 - 16 A/32 A

Amp	Poles	Ord. No.	Dimensions (mm)										
			A	B	C	ØD	Ød1	E	F	G	H	J	K
16	3	103226	100	85	75	70	5,5	60	60	60	56	39	39
		103220, 103238	102	97	80	71			73	61	51	50	38
16	4	103233	109	85	75	78	5,5	60	60	66	60	41	39
		103221, 103227, 103239	106	97	80	79			73	67	56	52	38
16	5	103234	116	85	75	87	5,5	60	60	75	65	42	39
		103222, 103240	114	97	80	87			73	76	65	55	38
32	3	103229	130	95	80	93	5,5	60	70	80	72	47	42
		103223, 103241	120	97	80	93			73	75	65	59	48
32	4	103236	130	95	80	93	5,5	60	70	80	72	47	42
		103224, 103230, 103242	120	97	80	93			73	75	65	59	48
32	5	103237	136	95	80	100	5,5	60	70	85	72	49	42
		103225, 103243	127	97	80	100			73	80	70	61	48

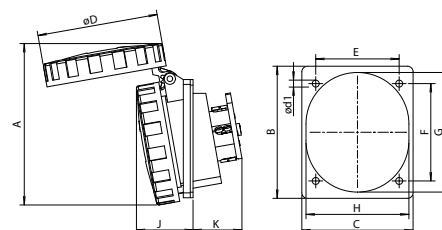

Panel sockets angled - Screwless IP67 - 16 A/32 A

Amp	Poles	Ord. No.	Dimensions (mm)										
			A	B	C	ØD	Ød1	E	F	G	H	J	K
16	3	103310, 103316	102	97	80	71	5,5	60	73	61	51	50	41
16	4	103311, 103317, 103323	106	97	80	79	5,5	60	73	67	56	52	41
16	5	103312, 103318, 103324	114	97	80	87	5,5	60	73	76	65	55	41
32	3	103313, 103319	120	97	80	93	5,5	60	73	75	65	59	48
32	4	103314, 103320, 103326	120	97	80	93	5,5	60	73	75	65	59	48
32	5	103315, 103321, 103327	127	97	80	100	5,5	60	73	80	70	61	48

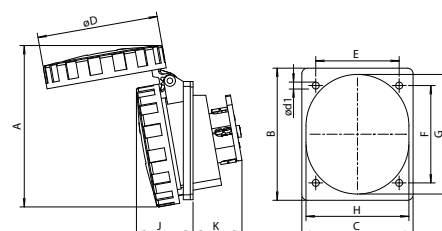

Panel sockets angled IP67 - 63 A

- Screw contacts.
- Flexible/rigid conductors 6 - 16/6 - 25 mm².



103408

Complies with standards: IEC 60309-1, -2
STN EN 60309-1, -2
Material: PA6, ABS
Surface treatment contacts: nickel-plated brass
Operating temperature: -25 °C to +55 °C

Amp.	Poles	110 V~ 50/60 Hz	230 V~ 50/60 Hz	400 V~ 50/60 Hz	500 V~ 50/60 Hz	Pkg. (pcs.)
		4h	3p=6h 4p+5p=9h	3p=9h 4p+5p=6h	7h	
63	3	103400 (IEGN 6331)	103403 (IEGN 6332)			2 / 2 / - / -
63	4	103401 (IEGN 6341)		103407 (IEGN 6343)	103410 (IEGN 6345)	2 / - / 2 / 2
63	5	103402 (IEGN 6351)		103408 (IEGN 6353)		2 / - / 8 / -

Panel sockets angled IP67 - 125 A

- Screw contacts.
- Flexible/rigid conductors 16 - 50/16 - 70 mm².



103500

Complies with standards: IEC 60309-1, -2
STN EN 60309-1, -2
Material: PA6, ABS
Surface treatment contacts: nickel-plated brass
Operating temperature: -25 °C to +55 °C

Amp.	Poles	110 V~ 50/60 Hz	230 V~ 50/60 Hz	400 V~ 50/60 Hz	500 V~ 50/60 Hz	Pkg. (pcs.)
		4h	3p=6h 4p+5p=9h	3p=9h 4p+5p=6h	7h	
125	3	103480 (IEGN 12531)	103489 (IEGN 12532)			2 / 2 / - / -
125	4	103481 (IEGN 12541)		103499 (IEGN 12543)	103508 (IEGN 12545)	2 / - / 2 / 2
125	5	103482 (IEGN 12551)		103500 (IEGN 12553)	103509 (IEGN 12555)	2 / - / 2 / 2

With pilot contact

125	3	103483 (IEGN 12531-p)	103492 (IEGN 12532-p)			2 / 2 / - / -
125	4	103484 (IEGN 12541-p)		103502 (IEGN 12543-p)	103511 (IEGN 12545-p)	2 / - / 2 / 2
125	5	103485 (IEGN 12551-p)		103503 (IEGN 12553-p)	103512 (IEGN 12555-p)	2 / - / 2 / 2

Panel sockets straight IP44/IP54 - 16 A/32 A

- Screw contacts.
- 16 A - flexible/rigid conductors 1 - 2,5/1 - 4 mm².
- 32 A - flexible/rigid conductors 2,5 - 6/2,5 - 10 mm².
- Ord. No. 103576, 103579, 103583, 103584, 106586, 103587 have IP54 protection.



103576

Complies with standards: IEC 60309-1, -2
STN EN 60309-1, -2
Material: PA6, ABS
Surface treatment contacts: passivated brass
Operating temperature: -25 °C to +55 °C

Amp.	Poles	110 V~ 50/60 Hz	230 V~ 50/60 Hz	400 V~ 50/60 Hz	500 V~ 50/60 Hz	Pkg. (pcs.)
		4h	3p=6h 4p+5p=9h	3p=9h 4p+5p=6h	7h	
16	3	103570 (IERN 1631)	103576 (IERN 1632)			10 / 10 / - / -
16	4			103583 (IERN 1643)		- / - / 10 / -
16	5			103584 (IERN 1653)		- / - / 10 / -
32	3	103573 (IERN 3231)	103579 (IERN 3232)			10 / 10 / - / -
32	4			103586 (IERN 3243)		- / - / 10 / -
32	5			103587 (IERN 3253)		- / - / 10 / -



Panel sockets angled IP67 - 63 A

Amp	Poles	Ord. No.	Dimensions (mm)										
			A	B	C	Ø D	Ø d1	E	F	G	H	J	K
63	3	103400, 103403	148	110	106	112	7	90	90	92	82	80	64
63	4	103401, 103407, 103410	148	110	106	112	7	90	90	92	82	80	64
63	5	103408	150	110	110	110	6,5	90	90	95	85	80	65
		103402	148	110	106	112	7	90	90	92	82	80	64

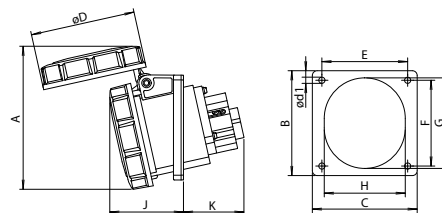

Panel sockets angled IP67 - 125 A

Amp	Poles	Ord. No.	Dimensions (mm)										
			A	B	C	Ø D	Ø d1	E	F	G	H	J	K
125	3	103480, 103489	160	114	114	124	7	90	90	102	90	77	92
125	4	103481, 103499, 103508	160	114	114	124	7	90	90	102	90	77	92
125	5	103482, 103500, 103509	160	114	114	124	7	90	90	102	90	77	92

With pilot contact

125	3	103483, 103492	160	114	114	124	7	90	90	102	90	77	92
125	4	103484, 103502, 103511	160	114	114	124	7	90	90	102	90	77	92
125	5	103485, 103503, 103512	160	114	114	12	7	90	90	102	90	77	92

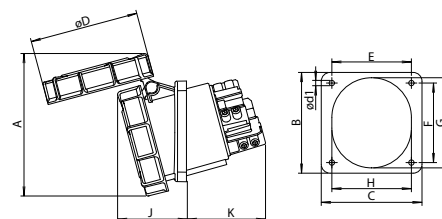

Panel sockets straight IP44/IP54 - 16 A/32 A

Amp	Poles	Ord. No.	Dimensions (mm)										
			A	B	C	Ø d1	Ø D	E	F	J	K		
16	3	103576	99	75	75	4,2	58	60	60	65	12		
		103570	87	70	70	5,5	43	56	56	55	21		
16	4	103583	94	75	75	4,2	58	60	60	64	13		
16	5	103584	99	75	75	4,2	58	60	60	66	13		
32	3	103579	102	75	75	4,2	63	60	60	75	18		
		103573	112	70	70	5,5	55	56	56	67	23		
32	4	103586	102	75	75	4,2	63	60	60	75	18		
32	5	103587	112	75	75	4,2	63	60	60	77	18		

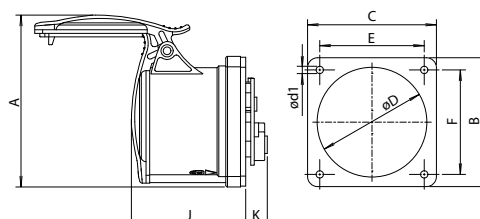

Panel sockets straight - Screwless IP54 - 16 A/32 A

- Screwless contacts.
- 16 A - flexible/rigid conductors 1 - 2,5/1 - 4 mm².
- 32 A - flexible/rigid conductors 2,5 - 6/2,5 - 10 mm².



103674

Complies with standards: IEC 60309-1, -2
STN EN 60309-1, -2
Material: PA6, ABS
Surface treatment contacts: passivated brass
Operating temperature: -25 °C to +55 °C

Amp.	Poles	Ord. No. (Type)				Pkg. (pcs.)
		110 V~ 50/60 Hz 4h	230 V~ 50/60 Hz 3p=6h 4p+5p=9h	400 V~ 50/60 Hz 3p=9h 4p+5p=6h	500 V~ 50/60 Hz 7h	
16	5			103674 (IERB 1653)		- / - / 10 / -
32	5			103676 (IERB 3253)		- / - / 10 / -

House sockets 250 V - IP54/IP55

- Screw contacts.
- 16 A - flexible/rigid conductors 1 - 2,5/1 - 2,5 mm².
- House sockets ord. No 103751, 103753 - Schuko system.
- On an uneven surfaces to be used with sealing ord. No. 105770 for IP 54.
- Socket ord. No. 103759 is 5P/440V/16A.
- Ord. No. 103757, 103758, 103759 have IP55 protection.



103751

Complies with standards: IEC 60309-1, -2
STN EN 60309-1, -2
Material: PA6, ABS
Surface treatment contacts: passivated brass
Operating temperature: -25 °C to +55 °C

French system					German system				
Amp.	Poles	Ord. No. (Type)	Colour	Pkg. (pcs.)	Amp.	Poles	Ord. No. (Type)	Colour	Pkg. (pcs.)
16	3	103750 (VZ 16)	blue	10	16	3	103751 (VZ 16S)	blue	10
16	3	103752 (VZ 16/Black)	black	10	16	3	103753 (VZ 16S/Black)	black	10

Danish system				Italian system				British system			
Amp.	Poles	Ord. No. (Type)	Pkg. (pcs.)	Amp.	Poles	Ord. No. (Type)	Pkg. (pcs.)	Amp.	Poles	Ord. No. (Type)	Pkg. (pcs.)
16	3	103754 (VZ 16DK)	100	16	3	103755 (VZ 16IT)	100	13	3	103756 (VZ 16GB)	100

Swiss system (version) T13				Swiss system (version) T23				Swiss system (version) T25			
Amp.	Poles	Ord. No. (Type)	Pkg. (pcs.)	Amp.	Poles	Ord. No. (Type)	Pkg. (pcs.)	Amp.	Poles	Ord. No. (Type)	Pkg. (pcs.)
10	3	103757 (VZ 16T13)	100	16	3	103758 (VZ 16T23)	100	16	5	103759 (VZ 16T25)	100

House sockets 250 V - IP67

- Screw contacts.
- House socket Or. No 103791 with child protection, 100792 - Schuko system.
- 16 A - flexible/rigid conductors 1 - 2,5/1 - 2,5 mm².



103790

Complies with standards: IEC 60309-1, -2
STN EN 60309-1, -2
Material: PA6, ABS
Surface treatment contacts: passivated brass
Operating temperature: -25 °C to +55 °C

French system				French system				German system			
Amp.	Poles	Ord. No. (Type)	Pkg. (pcs.)	Amp.	Poles	Ord. No. (Type)	Pkg. (pcs.)	Amp.	Poles	Ord. No. (Type)	Pkg. (pcs.)
16	3	103790 (VZG 16)	10	16	3	103791 (VZG 16C)	10	16	3	103792 (VZG 16S)	10



Panel sockets straight - Screwless IP44 - 16 A/32 A

Amp	Poles	Ord. No.	Dimensions (mm)								
			A	B	C	ø d1	ø D	E	F	J	K
16	5	103674	99	75	75	4,2	58	60	60	66	12
32	5	103676	112	75	75	4,2	63	60	60	77	21

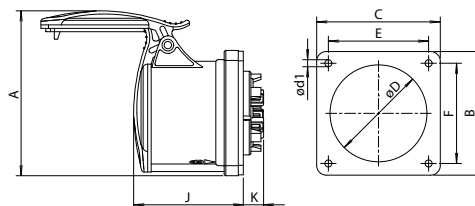

House sockets 250 V - IP54/IP55

Amp	Poles	Ord. No.	Dimensions (mm)							
			A	B	C	D	E	F	ØG	ØH
16	3	103750	50	38	60	25	20	23	43	4,5
16	3	103751	50	38	60	25	20	23	43	4,5
16	3	103752	50	38	60	25	20	23	43	4,5
16	3	103753	50	38	60	25	20	23	43	4,5
16	3	103754	50	38	60	24,5	23	30	-	4,2
16	3	103755	50	38	61,5	25,5	14,5	29	-	4,2
13	3	103756	50	38	64	25	18	22	35	4,2
10	3	103757	50	38	62	25	34	24	42	4,5
16	3	103758	50	38	62	25	34	24	42	4,5
16	5	103759	50	38	62	25	34	29	42	4,5

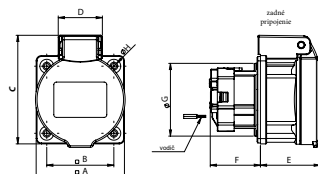
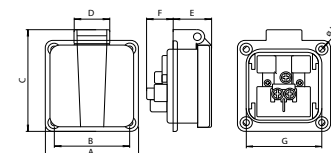
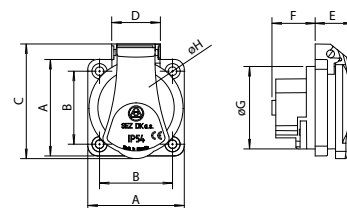

House sockets 250 V - IP67

Amp	Poles	Ord. No.	Dimensions (mm)								
			A	B	C	D	E	F	øG	øH	øI
16	3	103790	55	38	73	25	24	18	43	4,5	65
16	3	103791	55	38	73	25	24	18	43	4,5	65
16	3	103792	55	38	73	25	24	18	43	4,5	65

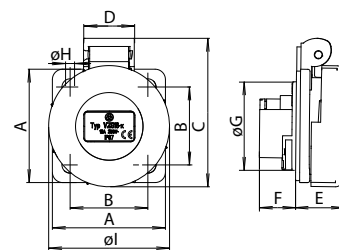

House sockets 48 V - IP54

- Screw contacts.
- It is possible to insert the plug with flat pins 10 A/48 V into this socket, which is in accordance with the norm STN 35 4517 modification "K" (2P). VZ 48 socket can also be used in case of lower voltage, i. e. 24 V or 12 V. For that case it is necessary to add an extra label where applied voltage is written.



103830

Complies with standards:	IEC 60309-1, -2 STN EN 60309-1, -2
Material:	PA6, ABS
Surface treatment contacts:	passivated brass
Operating temperature:	-25 °C to +55 °C

Amp.	Poles	110 V~ 50/60 Hz	48 V AC/DC 50 Hz	400 V~ 50/60 Hz	500 V~ 50/60 Hz	Pkg. (pcs.)
		4h	3p=6h 4p+5p=9h	3p=9h 4p+5p=6h	7h	
10	2	Ord. No. (Type)				- / 2 / - / -
			103830 (VZ 48)			

Panel inlets angled IP44 - 16 A/32 A

- Screw contacts.
- 16 A - flexible/rigid conductors 1 - 2,5/1 - 4 mm².
- 32 A - flexible/rigid conductors 2,5 - 6/2,5 - 10 mm².



103857

Complies with standards:	IEC 60309-1, -2 STN EN 60309-1, -2
Material:	PA6, ABS
Surface treatment contacts:	passivated brass
Operating temperature:	-25 °C to +55 °C

Amp.	Poles	110 V~ 50/60 Hz	230 V~ 50/60 Hz	400 V~ 50/60 Hz	500 V~ 50/60 Hz	Pkg. (pcs.)
		4h	3p=6h 4p+5p=9h	3p=9h 4p+5p=6h	7h	
16	3	Ord. No. (Type)				- / 2 / - / -
			103846 (IR 1632)			
16	4			103853 (IR 1643)		- / - / 2 / -
16	5			103854 (IR 1653)		- / - / 2 / -
32	3	Ord. No. (Type)				- / 2 / - / -
			103849 (IR 3232)			
32	4			103856 (IR 3243)		- / - / 2 / -
32	5			103857 (IR 3253)		- / - / 2 / -

Panel inlets angled IP67 - 16 A/32 A

- Screw contacts.
- 16 A - flexible/rigid conductors 1 - 2,5/1 - 4 mm².
- 32 A - flexible/rigid conductors 2,5 - 6/2,5 - 10 mm².



103947

Complies with standards:	IEC 60309-1, -2 STN EN 60309-1, -2
Material:	PA6, ABS
Surface treatment contacts:	passivated brass
Operating temperature:	-25 °C to +55 °C

Amp.	Poles	110 V~ 50/60 Hz	230 V~ 50/60 Hz	400 V~ 50/60 Hz	500 V~ 50/60 Hz	Pkg. (pcs.)
		4h	3p=6h 4p+5p=9h	3p=9h 4p+5p=6h	7h	
16	3	Ord. No. (Type)				- / 2 / - / -
			103936 (IRG 1632)			
16	4			103943 (IRG 1643)		- / - / 2 / -
16	5			103944 (IRG 1653)		- / - / 2 / -
32	3	Ord. No. (Type)				- / 2 / - / -
			103939 (IRG 3232)			
32	4			103946 (IRG 3243)		- / - / 2 / -
32	5			103947 (IRG 3253)		- / - / 2 / -

Products may differ from the illustration.



House sockets 48 V - IP54

Amp	Poles	Ord. No.	Dimensions (mm)							
			A	B	C	D	E	F	ø G	ø H
10	2	103830	50	38	59,5	25	22	17	43	4,5

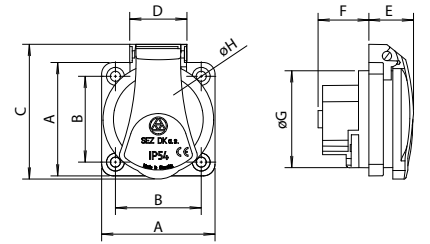

Panel inlets angled IP44 - 16 A/32 A

Amp	Poles	Ord. No.	Dimensions (mm)							
			A	B	C	ø d	D	E	F	G
16	3	103846	89	66	57	4,8	20	43	-	49
16	4	103853	98	78	65	4,8	27	50	-	58
16	5	103854	98	78	65	4,8	27	50	-	58
32	3	103849	127	88	72	5,5	9	58	40	79
32	4	103856	127	88	72	5,5	9	58	40	79
32	5	103857	128	91	72	5,5	9	58	40	79

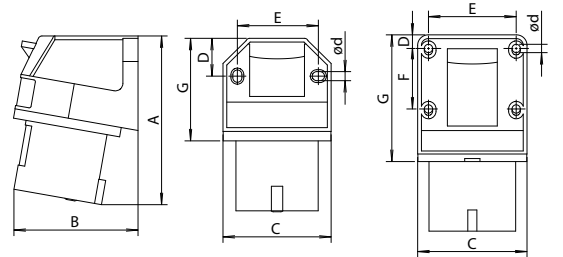

Panel inlets angled IP67 - 16 A/32 A

Amp	Poles	Ord. No.	Dimensions (mm)							
			A	B	C	ø d	D	E	F	G
16	3	103936	111	82	70	4,8	15	45	30	60
16	4	103943	115	93	78	5,2	17,5	50	30	65
16	5	103944	115	93	78	5,2	17,5	50	30	65
32	3	103939	139	109	93	5,2	20	58	40	80
32	4	103946	139	109	93	5,2	20	58	40	80
32	5	103947	139	113	100	5,2	20	58	40	80

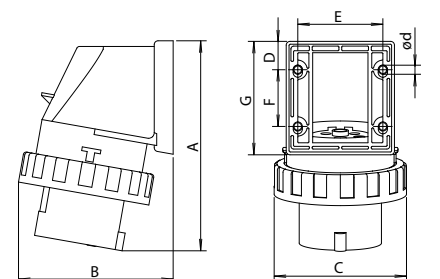

Panel inlets angled IP67 - 63 A

- Screw contacts.
- Flexible/rigid conductors 6 - 16/6 - 25 mm².



104028

Complies with standards: IEC 60309-1, -2
STN EN 60309-1, -2
Material: PA6, ABS
Surface treatment contacts: nickel-plated brass
Operating temperature: -25 °C to +55 °C

Amp.	Poles	Ord. No. (Type)				Pkg. (pcs.)
		110 V~ 50/60 Hz 4h	230 V~ 50/60 Hz 3p=6h 4p+5p=9h	400 V~ 50/60 Hz 3p=9h 4p+5p=6h	500 V~ 50/60 Hz 7h	
63	3	104020 (IRGN 6331)	104023 (IRGN 6332)		104029 (IRGN 6335)	2 / 2 / - / 2
63	4	104021 (IRGN 6341)	104024 (IRGN 6342)	104027 (IRGN 6343)	104030 (IRGN 6345)	2 / 2 / 2 / 2
63	5	104022 (IRGN 6351)	104025 (IRGN 6352)	104028 (IRGN 6353)	104031 (IRGN 6355)	2 / 2 / 2 / 2

Panel inlets straight IP44/IP54 - 16 A/32 A

- Screw contacts.
- 16 A - flexible/rigid conductors 1 - 2,5/1 - 4 mm².
- 32 A - flexible/rigid conductors 2,5 - 6/2,5 - 10 mm².
- Ord. No. 104076, 104079, 104083, 104084, 104086, 104087 have IP54 protection.



104084

Complies with standards: IEC 60309-1, -2
STN EN 60309-1, -2
Material: PA6, ABS
Surface treatment contacts: passivated brass
Operating temperature: -25 °C to +55 °C

Amp.	Poles	Ord. No. (Type)				Pkg. (pcs.)
		110 V~ 50/60 Hz 4h	230 V~ 50/60 Hz 3p=6h 4p+5p=9h	400 V~ 50/60 Hz 3p=9h 4p+5p=6h	500 V~ 50/60 Hz 7h	
16	3	104070 (IRRN 1631)	104076 (IRRN 1632)		104088 (IRRN 1635)	10 / 2 / - / 10
16	4	104071 (IRRN 1641)		104083 (IRRN 1643)	104089 (IRRN 1645)	10 / - / 2 / 10
16	5	104072 (IRRN 1651)		104084 (IRRN 1653)	104090 (IRRN 1655)	10 / - / 2 / 10
32	3	104073 (IRRN 3231)	104079 (IRRN 3232)		104091 (IRRN 3235)	10 / 2 / - / 10
32	4	104074 (IRRN 3241)		104086 (IRRN 3243)	104092 (IRRN 3245)	10 / - / 2 / 10
32	5	104075 (IRRN 3251)		104087 (IRRN 3253)	104093 (IRRN 3255)	10 / - / 2 / 10

Panel inlets straight - Screwless IP44/IP54 - 16 A/32 A

- Screwless contacts.
- 16 A - flexible/rigid conductors 1 - 2,5/1 - 4 mm².
- 32 A - flexible/rigid conductors 2,5 - 6/2,5 - 10 mm².
- Ord. No. 104174, 104177 have IP54 protection.



104174

Complies with standards: IEC 60309-1, -2
STN EN 60309-1, -2
Material: PA6, ABS
Surface treatment contacts: passivated brass
Operating temperature: -25 °C to +55 °C

Amp.	Poles	Ord. No. (Type)				Pkg. (pcs.)
		110 V~ 50/60 Hz 4h	230 V~ 50/60 Hz 3p=6h 4p+5p=9h	400 V~ 50/60 Hz 3p=9h 4p+5p=6h	500 V~ 50/60 Hz 7h	
16	3	104160 (IRRB 1631)	104166 (IRRB 1632)			10/10 / - / -
16	5	104162 (IRRB 1651)	104168 (IRRB 1652)	104174 (IRRB 1653)		10/10 / 2 / -
32	4	104164 (IRRB 3241)	104170 (IRRB 3242)			10/10 / - / -
32	5	104165 (IRRB 3251)	104171 (IRRB 3252)	104177 (IRRB 3253)		10/10 / 2 / -



Panel inlets angled IP67 - 63 A

Amp	Poles	Ord. No.	Dimensions (mm)								
			A	B	C	Ød1	ØD	E	F	J	K
63	3	104020, 104023, 104029	127	112	100	7	80	80	88	127	8
63	4	104021, 104024, 104027, 104030	127	112	100	7	80	80	88	127	8
63	5	104022, 104025, 104028, 104031	127	112	100	7	80	80	88	127	8

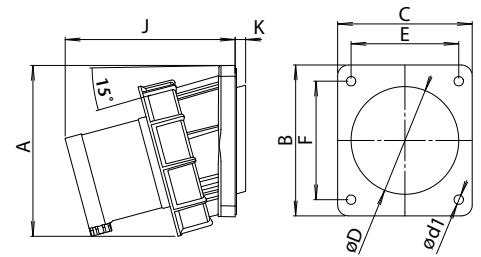

Panel inlets straight IP44/IP54 - 16 A/32 A

Amp	Poles	Ord. No.	Dimensions (mm)								
			A	B	C	Ød1	ØD	E	F	J	K
16	3	104076	-	75	75	4	57	60	60	48	19
		104070, 104088	-	70	70	5,5	43	56	56	42	21
16	4	104083	-	75	75	4	57	60	60	48	18
		104071, 104089	-	70	70	5,5	43	56	56	42	21
16	5	104084	-	75	75	4	57	60	60	48	18
		104072, 104090	-	70	70	5,5	55	56	56	42	20
32	3	104079	-	75	75	4	64	60	60	58	16
		104073, 104091	-	70	70	5,5	55	56	56	51	21
32	4	104086	-	75	75	4	64	60	60	58	16
		104074, 104092	-	70	70	5,5	55	56	56	51	21
32	5	104087	80	75	75	4	64	60	60	58	16
		104075, 104093	-	70	70	5,5	55	56	56	51	21

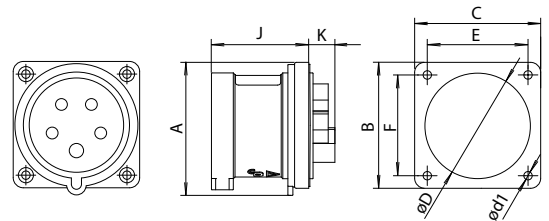

Panel inlets straight - Screwless IP44/IP54 - 16 A/32 A

Amp	Poles	Ord. No.	Dimensions (mm)								
			A	B	C	Ød1	ØD	E	F	J	K
16	3	104160, 104166	-	70	70	5,5	43	56	56	42	26
16	5	104174	-	75	75	4	57	60	60	51	12
		104162, 104168	-	70	70	5,5	55	56	56	42	26
32	4	104164, 104170	-	70	70	5,5	55	56	56	51	29
32	5	104177	79	75	75	4	64	60	60	61	19
		104165, 104171	-	70	70	5,5	55	56	56	51	29

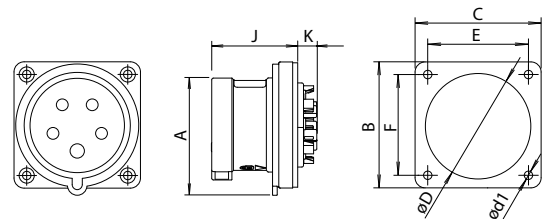

Panel inlets - Phase reverse IP44 - 16 A/32 A

- Screw contacts.
- 16 A - flexible/rigid conductors 1-2,5/1 - 4 mm².
- 32 A - flexible/rigid conductors 2,5 - 6/2,5 - 10 mm².
- In position can be changed by turning the screwdriver by 180 degrees to achieve the phase change.



104267

Complies with standards: IEC 60309-1, -2
STN EN 60309-1, -2
Material: PA6, ABS
Surface treatment contacts: passivated brass
Operating temperature: -25 °C to +55 °C

Amp.	Poles	Ord. No. (Type)				Pkg. (pcs.)
		110 V~ 50/60 Hz 4h	230 V~ 50/60 Hz 3p=6h 4p+5p=9h	400 V~ 50/60 Hz 3p=9h 4p+5p=6h	500 V~ 50/60 Hz 7h	
16	5			104264 (IRRNO 1653)		- / - / 2 / -
32	4			104266 (IRRNO 3243)		- / - / 10 / -
32	5			104267 (IRRNO 3253)		- / - / 2 / -

Panel inlets straight IP67 - 16 A/32 A

- Screw contacts.
- 16 A - flexible/rigid conductors 1 - 2,5/1 - 4 mm².
- 32 A - flexible/rigid conductors 2,5 - 6/2,5 - 10 mm².



104324

Complies with standards: IEC 60309-1, -2
STN EN 60309-1, -2
Material: PA6, ABS
Surface treatment contacts: passivated brass
Operating temperature: -25 °C to +55 °C

Amp.	Poles	Ord. No. (Type)				Pkg. (pcs.)
		110 V~ 50/60 Hz 4h	230 V~ 50/60 Hz 3p=6h 4p+5p=9h	400 V~ 50/60 Hz 3p=9h 4p+5p=6h	500 V~ 50/60 Hz 7h	
16	3	104310 (IRRGN 1631)			104328 (IRRGN 1635)	10 / - / - / 10
16	4	104311 (IRRGN 1641)			104329 (IRRGN 1645)	10 / - / - / 10
16	5	104312 (IRRGN 1651)		104324 (IRRG 1653)	104330 (IRRGN 1655)	10 / - / 2 / 10
32	3	104313 (IRRGN 3231)			104331 (IRRGN 3235)	10 / - / - / 10
32	4	104314 (IRRGN 3241)			104332 (IRRGN 3245)	10 / - / - / 10
32	5	104315 (IRRGN 3251)		104327 (IRRG 3253)	104333 (IRRGN 3255)	10 / - / 2 / 10

Panel inlets straight - Screwless IP67 - 16 A/32 A

- Screwless contacts.
- 16 A - flexible/rigid conductors 1 - 2,5/1 - 4 mm².
- 32 A - flexible/rigid conductors 2,5 - 6/2,5 - 10 mm².



104414

Complies with standards: IEC 60309-1, -2
STN EN 60309-1, -2
Material: PA6, ABS
Surface treatment contacts: passivated brass
Operating temperature: -25 °C to +55 °C

Amp.	Poles	Ord. No. (Type)				Pkg. (pcs.)
		110 V~ 50/60 Hz 4h	230 V~ 50/60 Hz 3p=6h 4p+5p=9h	400 V~ 50/60 Hz 3p=9h 4p+5p=6h	500 V~ 50/60 Hz 7h	
16	3	104400 (IRRGB 1631)	104406 (IRRGB 1632)			10 / 10 / - / -
16	5	104402 (IRRGB 1651)	104408 (IRRGB 1652)	104414 (IRRGB 1653)		10 / 10 / 10 / -
32	4	104404 (IRRGB 3241)	104410 (IRRGB 3242)	104416 (IRRGB 3243)		10 / 10 / 10 / -
32	5	104405 (IRRGB 3251)	104411 (IRRGB 3252)	104417 (IRRGB 3253)		10 / 10 / 10 / -



Panel inlets - Phase reverse IP44 - 16 A/32 A

Amp	Poles	Ord. No.	Dimensions (mm)								
			A	B	C	Ød1	ØD	E	F	J	K
16	5	104264	-	75	75	4,2	57	60	60	48	18
32	4	104266	-	70	70	5,5	55	56	56	51	21
32	5	104267	80	75	75	4,2	64	60	60	58	15

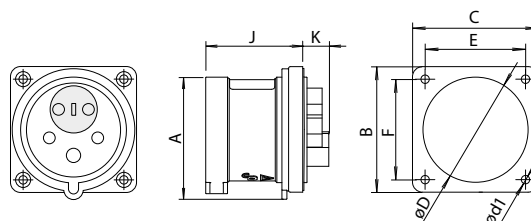

Panel inlets straight IP67 - 16 A/32 A

Amp	Poles	Ord. No.	Dimensions (mm)									
			ØA	B	C	Ød1	ØD	E	F	J	K	L
16	3	104310, 104328	71	75	75	5,5	43	60	60	48	15	11,3
16	4	104311, 104329	79	75	75	5,5	44	60	60	48	14	6
16	5	104324	87	85	75	4	65	64	73	59	22	0
		104312, 104330	87	75	75	5,5	55	60	60	48	13	5
32	3	104313, 104331	93	75	75	5,5	55	60	60	58	14	4,5
32	4	104314, 104332	93	75	75	5,5	55	60	60	58	15	4,5
32	5	104327	100	95	80	4	71	70	84	72	24	0
		104315, 104333	100	75	75	5,5	55	60	60	58	14	0

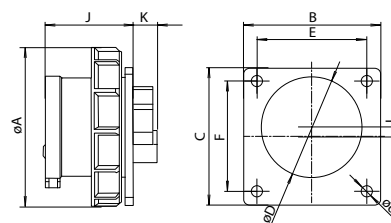

Panel inlets straight - Screwless IP67 - 16 A/32 A

Amp	Poles	Ord. No.	Dimensions (mm)									
			ØA	B	C	Ød1	ØD	E	F	J	K	L
16	3	104400, 104406	71	75	75	5,5	43	60	60	48	20	11,3
16	5	104402, 104408, 104414	87	75	75	5,5	55	60	60	48	20	5
32	4	104404, 104410, 104416	93	75	75	5,5	55	60	60	58	21	4,5
32	5	104405, 104411, 104417	100	75	75	5,5	55	60	60	58	21	0

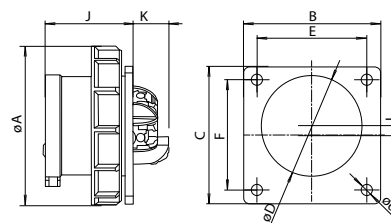

Panel inlets straight IP67 - 63 A

- Screw contacts.
- Flexible/rigid conductors 6 - 16/6 - 25 mm².



104498

Complies with standards: IEC 60309-1, -2
STN EN 60309-1, -2
Material: PA6, ABS
Surface treatment contacts: nickel-plated brass
Operating temperature: -25 °C to +55 °C

Amp.	Poles	Ord. No. (Type)				Pkg. (pcs.)
		110 V~ 50/60 Hz 4h	230 V~ 50/60 Hz 3p=6h 4p+5p=9h	400 V~ 50/60 Hz 3p=9h 4p+5p=6h	500 V~ 50/60 Hz 7h	
63	3	104490 (IRRGN 6331)	104493 (IRRGN 6332)			2 / 2 / - / -
63	4	104491 (IRRGN 6341)		104497 (IRRGN 6343)		2 / - / 2 / -
63	5	104492 (IRRGN 6351)		104498 (IRRGN 6353)		2 / - / 2 / -

Panel inlets straight IP67 -125 A

- Screw contacts.
- Flexible/rigid conductors 16 - 50/16 - 70 mm².



104548

Complies with standards: IEC 60309-1, -2
STN EN 60309-1, -2
Material: PA6, ABS
Surface treatment contacts: nickel-plated brass
Operating temperature: -25 °C to +55 °C

Amp.	Poles	Ord. No. (Type)				Pkg. (pcs.)
		110 V~ 50/60 Hz 4h	230 V~ 50/60 Hz 3p=6h 4p+5p=9h	400 V~ 50/60 Hz 3p=9h 4p+5p=6h	500 V~ 50/60 Hz 7h	
125	3	104540 (IRRGN 12531)	104543 (IRRGN 12532)			2 / 2 / - / -
125	4	104541 (IRRGN 12541)		104547 (IRRGN 12543)	104550 (IRRGN 12545)	2 / - / 2 / 2
125	5	104542 (IRRGN 12551)		104548 (IRRGN 12553)	104551 (IRRGN 12555)	2 / - / 2 / 2

Adapters IP44 400 V 5P -> 4P - 16 A/32 A

- Screw contacts.
- The use of the adapter A 5p/4p is determined by the symmetrical load since the 4-pole socket connection is 3P+PE.



104634

Complies with standards: IEC 60309-1, -2
STN EN 60309-1, -2
Material: PA6, ABS
Surface treatment contacts: passivated brass
Operating temperature: -25 °C to +55 °C

Amp.	Poles	Ord. No. (Type)				Pkg. (pcs.)
		110 V~ 50/60 Hz 4h	230 V~ 50/60 Hz 3p=6h 4p+5p=9h	400 V~ 50/60 Hz 3p=9h 4p+5p=6h	500 V~ 50/60 Hz 7h	
16	5/4			104634 (A 1653/43)		- / - / 2 / -
32	5/4			104637 (A 3253/43)		- / - / 2 / -



Panel inlets straight IP67 - 63 A

Amp	Poles	Ord. No.	Dimensions (mm)								
			ØA	B	C	Ød1	ØD	E	F	J	K
63	3	104490, 104493	115	100	100	8	77	80	80	109	7
63	4	104491, 104497	115	100	100	8	77	80	80	109	7
63	5	104492, 104498	115	100	100	8	77	80	80	109	7

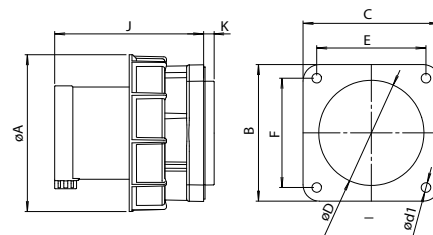

Panel inlets straight IP67 -125 A

Amp	Poles	Ord. No.	Dimensions (mm)								
			ØA	B	C	Ød1	ØD	E	F	J	K
125	3	104540,104543	131	120	120	7	95	100	100	118	13
125	4	10541,104547,104550	131	120	120	7	95	100	100	118	13
125	5	104542,104548,104551	131	120	120	7	95	100	1000	118	13

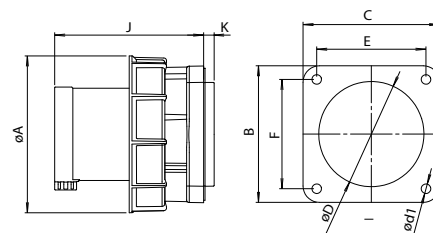

Adapters IP44 400 V 5P -> 4P - 16 A/32 A

Amp	Poles	Ord. No.	Dimensions (mm)			
			A	B	ØD	K
16	5/4	104634	180	82	64	39
32	5/4	104637	235	96	73	45

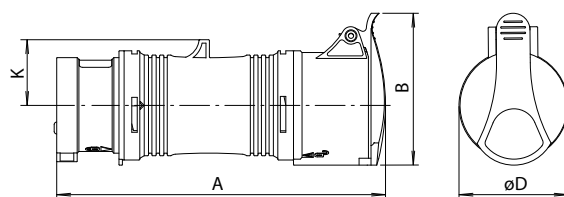

Adapters IP44 400 V 16 A -> 32 A - 4P/5P

- Screw contacts.



104694

Complies with standards: IEC 60309-1, -2
STN EN 60309-1, -2
Material: PA6, ABS
Surface treatment contacts: passivated brass
Operating temperature: -25 °C to +55 °C

Amp.	Poles	Ord. No. (Type)				Pkg. (pcs.)
		110 V~ 50/60 Hz 4h	230 V~ 50/60 Hz 3p=6h 4p+5p=9h	400 V~ 50/60 Hz 3p=9h 4p+5p=6h	500 V~ 50/60 Hz 7h	
16/32	4			104693 (A 16-32/4)		- / - / 2 / -
16/32	5			104694 (A 16-32/5)		- / - / 2 / -

Phase reverse adapters - fixed IP44 400 V - 16 A/32 A

- Screw contacts.



104754

Complies with standards: IEC 60309-1, -2
STN EN 60309-1, -2
Material: PA6, ABS
Surface treatment contacts: passivated brass
Operating temperature: -25 °C to +55 °C

Amp.	Poles	Ord. No. (Type)				Pkg. (pcs.)
		110 V~ 50/60 Hz 4h	230 V~ 50/60 Hz 3p=6h 4p+5p=9h	400 V~ 50/60 Hz 3p=9h 4p+5p=6h	500 V~ 50/60 Hz 7h	
16	4			104753 (RA 1643)		- / - / 2 / -
16	5			104754 (RA 1653)		- / - / 2 / -
32	4			104756 (RA 3243)		- / - / 2 / -
32	5			104757 (RA 3253)		- / - / 2 / -

Adapter IP 44 400 V 16 A -> 32 A with switchable phase reverse 5P

- Screw contacts.

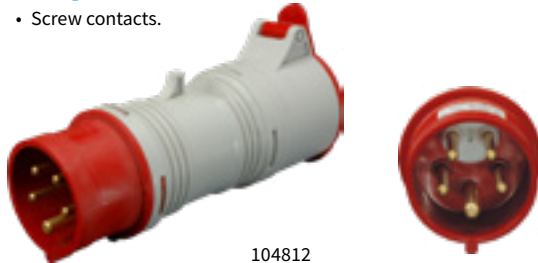

104812

Complies with standards: IEC 60309-1, -2
STN EN 60309-1, -2
Material: PA6, ABS
Surface treatment contacts: passivated brass
Operating temperature: -25 °C to +55 °C

Amp.	Poles	Ord. No. (Type)				Pkg. (pcs.)
		110 V~ 50/60 Hz 4h	230 V~ 50/60 Hz 3p=6h 4p+5p=9h	400 V~ 50/60 Hz 3p=9h 4p+5p=6h	500 V~ 50/60 Hz 7h	
16/32	5			104812 (A16-32/5-0)		- / - / 2 / -

Adapters IP 44 400 V 5P -> 4P - 16 A/32 A with switchable phase reverse

- Screw contacts.
- The use of the adapter A 5p/4p is determined by the symmetrical load since the 4-pole socket connection is 3P+PE.



104817

Complies with standards: IEC 60309-1, -2
STN EN 60309-1, -2
Material: PA6, ABS
Surface treatment contacts: passivated brass
Operating temperature: -25 °C to +55 °C

Amp.	Poles	Ord. No. (Type)				Pkg. (pcs.)
		110 V~ 50/60 Hz 4h	230 V~ 50/60 Hz 3p=6h 4p+5p=9h	400 V~ 50/60 Hz 3p=9h 4p+5p=6h	500 V~ 50/60 Hz 7h	
16	5/4			104814 (A1653/43-0)		- / - / 2 / -
32	5/4			104817 (A3253/43-0)		- / - / 2 / -

Products may differ from the illustration.



Adapters IP44 400 V 16 A -> 32 A 4P/5P

Amp	Poles	Ord. No.	Dimensions (mm)			
			A	B	ØD	K
16/32	4	104693	198	96	65	34
16/32	5	104694	200	103	73	37

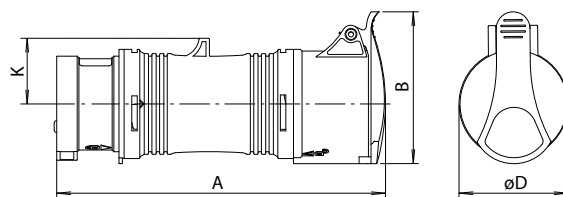

Phase reverse adapters - fixed IP44 400 V - 16 A/32 A

Amp	Poles	Ord. No.	Dimensions (mm)			
			A	B	ØD	K
16	4	104753	178	82	56	35
16	5	104754	180	89	64	39
32	4	104756	235	96	65	41
32	5	104757	237	104	73	45

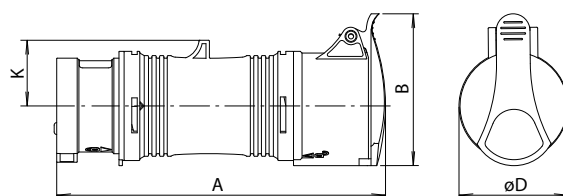

Adapter IP 44 400 V 16 A -> 32 A with switchable phase reverse 5P

Amp	Poles	Ord. No.	Dimensions (mm)			
			A	B	ØD	K
16/32	5	104812	200	103	73	37

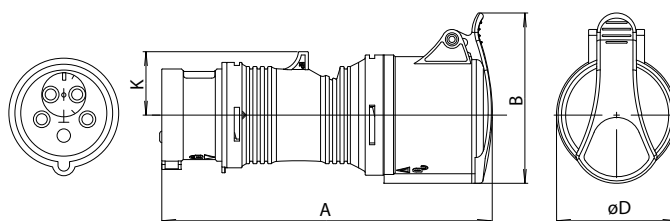

Adapters IP 44 400 V 5P -> 4P - 16 A/32 A with switchable phase reverse

Amp	Poles	Ord. No.	Dimensions (mm)			
			A	B	ØD	K
16	5/4	104814	180	82	64	39
32	5/4	104817	235	96	73	45

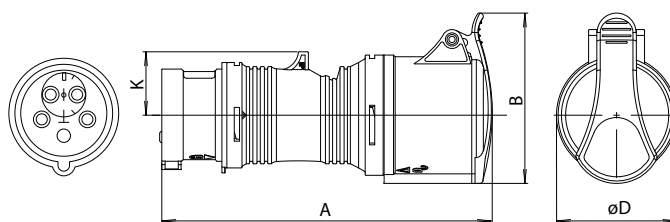

Cable adapters IP20 indust. plug 3P -> house socket

- Screw contacts.
- Ord. No. 104867 - house socket system Schuko.



104866

Complies with standards: IEC 60309-1, -2
STN EN 60309-1, -2
Material: PA6, ABS
Surface treatment contacts: passivated brass
Operating temperature: -25 °C to +55 °C

Amp.	Poles	110 V~ 50/60 Hz	230 V~ 50/60 Hz	400 V~ 50/60 Hz	500 V~ 50/60 Hz	Pkg. (pcs.)
		4h	3p=6h 4p+5p=9h	3p=9h 4p+5p=6h	7h	
		Ord. No. (Type)				
16	3		104866 (SA-1)			- / 1 / - / -
16	3		104867 (SA-1S)			- / 1 / - / -

Cable adapters IP20 indust. plug 5P -> house socket

- Ord. No. 104935 - house socket system Schuko.



104934

Complies with standards: IEC 60309-1, -2
STN EN 60309-1, -2
Material: PA6, ABS
Surface treatment contacts: passivated brass
Operating temperature: -25 °C to +55 °C

Amp.	Poles	110 V~ 50/60 Hz	230 V~ 50/60 Hz	400 V~ 50/60 Hz	500 V~ 50/60 Hz	Pkg. (pcs.)
		4h	3p=6h 4p+5p=9h	3p=9h 4p+5p=6h	7h	
		Ord. No. (Type)				
16	5			104934 (SA-2)		- / - / 1 / -
16	5			104935 (SA-2S)		- / - / 1 / -

Cable adapters IP20 house plug Uni-schuko -> indust. socket 3P

- Ord. No. 104986 - indust. plug 16A/3p.
- Ord. No. 104989 - indust. plug 32A/3p.



104989

Complies with standards: IEC 60309-1, -2
STN EN 60309-1, -2
Material: PA6, ABS
Surface treatment contacts: passivated brass
Operating temperature: -25 °C to +55 °C

Amp.	Poles	110 V~ 50/60 Hz	230 V~ 50/60 Hz	400 V~ 50/60 Hz	500 V~ 50/60 Hz	Pkg. (pcs.)
		4h	3p=6h 4p+5p=9h	3p=9h 4p+5p=6h	7h	
		Ord. No. (Type)				
16	3		104986 (SA-3)			- / 1 / - / -
32*	3		104989 (SA-4)			- / 1 / - / -

* nominal current for 32 A industrial socket is 16 A.



Cable adapters IP20 indust. plug 3P -> house socket

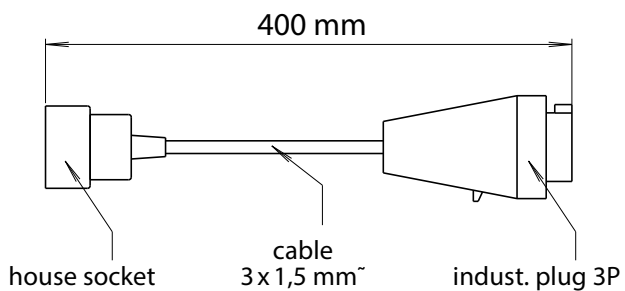

Cable adapters IP20 indust. plug 5P -> house socket

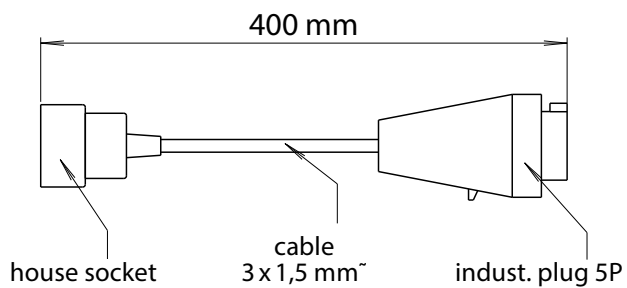

Cable adapters IP20 house plug Uni-schuko -> indust. socket 3P

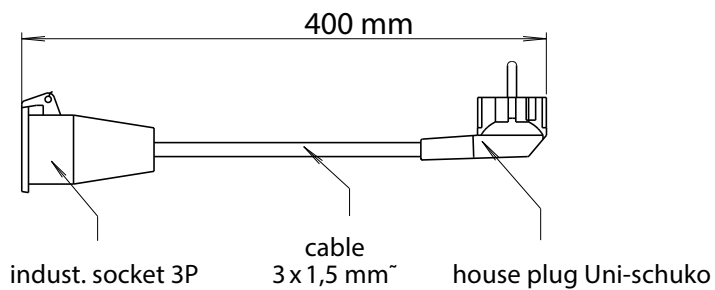

Switched interlocked sockets horizontal IP44 - 16 A/32 A

- Screw contacts.
- 16 A - flexible/rigid conductors 1 - 2,5/1 - 4 mm².
- 32 A - flexible/rigid conductors 2,5 - 6/2,5 - 10 mm².



105057

Complies with standards: IEC 60309-1, -4
STN EN 60309-1, -4
Material: PA6, ABS
Surface treatment contacts: passivated brass
Operating temperature: -25 °C to +55 °C

Amp.	Poles	110 V~ 50/60 Hz	230 V~ 50/60 Hz	400 V~ 50/60 Hz	500 V~ 50/60 Hz	Pkg. (pcs.)
		4h	3p=6h 4p+5p=9h	3p=9h 4p+5p=6h	7h	
16	3	105040 (BZS 1631)	105046 (BZS 1632)			1/1/ - / -
16	4	105041 (BZS 1641)	105047 (BZS 1642)	105053 (BZS 1643)		1/1/1/ -
16	5	105042 (BZS 1651)	105048 (BZS 1652)	105054 (BZS 1653)		1/1/1/ -
32	3	105043 (BZS 3231)	105049 (BZS 3232)			1/1/ - / -
32	4	105044 (BZS 3241)	105050 (BZS 3242)	105056 (BZS 3243)		1/1/1/ -
32	5	105045 (BZS 3251)	105051 (BZS 3252)	105057 (BZS 3253)		1/1/1/ -

Switched interlocked sockets horizontal IP67 - 16 A/32 A

- Screw contacts.
- 16 A - flexible/rigid conductors 1 - 2,5/1 - 4 mm².
- 32 A - flexible/rigid conductors 2,5 - 6/2,5 - 10 mm².



105143

Complies with standards: IEC 60309-1, -4
STN EN 60309-1, -4
Material: PA6, ABS
Surface treatment contacts: passivated brass
Operating temperature: -25 °C to +55 °C

Amp.	Poles	110 V~ 50/60 Hz	230 V~ 50/60 Hz	400 V~ 50/60 Hz	500 V~ 50/60 Hz	Pkg. (pcs.)
		4h	3p=6h 4p+5p=9h	3p=9h 4p+5p=6h	7h	
16	3	105130 (BZG 1631)	105136 (BZG 1632)			1/1/ - / -
16	4	105131 (BZG 1641)	105137 (BZG 1642)	105143 (BZG 1643)		1/1/1/ -
16	5	105132 (BZG 1651)		105144 (BZG 1653)		1/ - /1/ -
32	3	105133 (BZG 3231)	105139 (BZG 3232)			1/1/ - / -
32	4	105134 (BZG 3241)	105140 (BZG 3242)	105146 (BZG 3243)		1/1/1/ -
32	5	105135 (BZG 3251)		105147 (BZG 3253)		1/ - /1/ -

Switched interlocked sockets vertical IP44 - 16 A/32 A

- Screw contacts.
- 16 A - flexible/rigid conductors 1 - 2,5/1 - 4 mm².
- 32 A - flexible/rigid conductors 2,5 - 6/2,5 - 10 mm².



105234

Complies with standards: IEC 60309-1, -4
STN EN 60309-1, -4
Material: PA6, ABS
Surface treatment contacts: passivated brass
Operating temperature: -25 °C to +55 °C

Amp.	Poles	110 V~ 50/60 Hz	230 V~ 50/60 Hz	400 V~ 50/60 Hz	500 V~ 50/60 Hz	Pkg. (pcs.)
		4h	3p=6h 4p+5p=9h	3p=9h 4p+5p=6h	7h	
16	3	105220 (BZS 1631v)	105226 (BZS 1632v)		105238 (BZS 1635v)	1/1/ - / 1
16	4	105221 (BZS 1641v)	105227 (BZS 1642v)	105233 (BZS 1643v)	105239 (BZS 1645v)	1/1/1/ 1
16	5	105222 (BZS 1651v)	105228 (BZS 1652v)	105234 (BZS 1653v)	105240 (BZS 1655v)	1/1/1/ 1
32	3	105223 (BZS 3231v)	105229 (BZS 3232v)		105241 (BZS 3235v)	1/1/ - / 1
32	4	105224 (BZS 3241v)	105230 (BZS 3242v)	105236 (BZS 3243v)	105242 (BZS 3245v)	1/1/1/ 1
32	5	105225 (BZS 3251v)	105231 (BZS 3252v)	105237 (BZS 3253v)	105243 (BZS 3255v)	1/1/1/ 1

Products may differ from the illustration.



Switched interlocked sockets horizontal IP44 - 16 A/32 A

Amp	Poles	Ord. No.	Dimensions (mm)				
			A	B	C	D	E
16	3	105040, 105046	155	115	110,5	140	52
16	4	105041, 105047, 105053	155	115	110,5	140	52
16	5	105054	158	118	129	112	72
		105042, 105048	155	115	111,5	140	52
32	3	105043, 105049	155	115	122,5	140	52
32	4	105044, 10050, 105056	155	115	122,5	140	52
32	5	105057	158	118	129	112	72
		104045, 105051	155	115	123,5	140	52

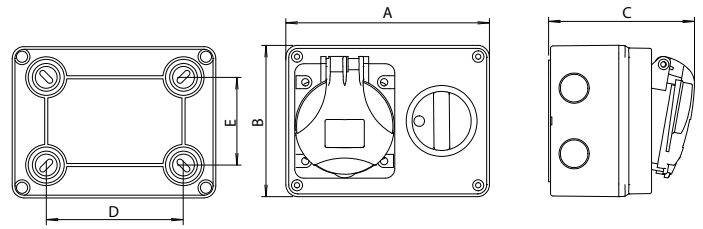

Switched interlocked sockets horizontal IP67 - 16 A/32 A

Amp	Poles	Ord. No.	Dimensions (mm)				
			A	B	C	D	E
16	3	105130, 105136	155	115	111,5	140	52
16	4	105131, 105137, 105143	155	115	113,5	140	52
16	5	105132, 105144	155	115	113,5	140	52
32	3	105133, 105139	155	115	122,5	140	52
32	4	105134, 105140, 105146	155	115	122,5	140	52
32	5	105135, 105147	155	115	122,5	140	52

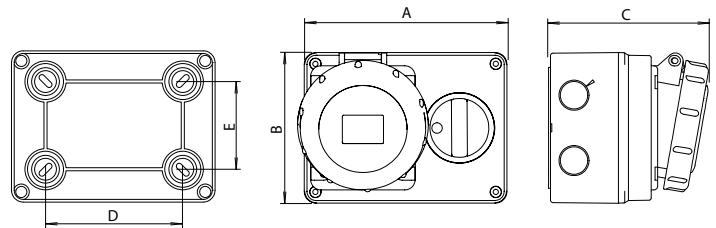

Switched interlocked sockets vertical IP44 - 16 A/32 A

Amp	Poles	Ord. No.	Dimensions (mm)				
			A	B	C	D	E
16	3	105220, 150226, 105238*	180	90	109/115*	140	52/60*
16	4	105221, 105227, 105233, 105239*	180	90	111/117*	140	52/60*
16	5	105222, 105228, 105234, 105240*	180	90	113/118*	140	52/60*
32	3	105223, 105229, 105241*	180	90	116/123*	140	52/60*
32	4	105224, 105230, 105236, 105242*	180	90	116/123*	140	52/60*
32	5	105225, 105231, 105237, 105243*	180	90	118/124*	140	52/60*

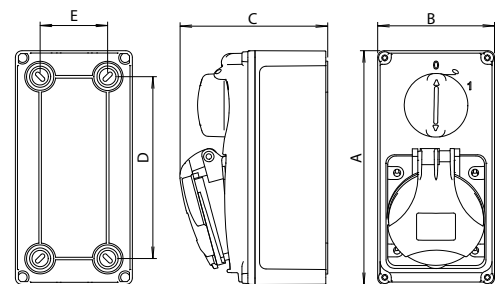

Switched interlocked sockets vertical IP67 - 16 A/32 A

- Screw contacts.
- 16 A - flexible/rigid conductors 1 - 2,5/1 - 4 mm².
- 32 A - flexible/rigid conductors 2,5 - 6/2,5 - 10 mm².



105324

Complies with standards: IEC 60309-1, -4
STN EN 60309-1, -4
Material: PA6, ABS
Surface treatment contacts: passivated brass
Operating temperature: -25 °C to +55 °C

Amp.	Poles	110 V~ 50/60 Hz	230 V~ 50/60 Hz	400 V~ 50/60 Hz	500 V~ 50/60 Hz	Pkg. (pcs.)
		4h	3p=6h 4p+5p=9h	3p=9h 4p+5p=6h	7h	
16	3	105310 (BZG 1631v)	105316 (BZG 1632v)		105328 (BZG 1635v)	1/1/ - /1
		105311 (BZG 1641v)	105317 (BZG 1642v)	105323 (BZG 1643v)	105329 (BZG 1645v)	1/1/1/1
16	5	105312 (BZG 1651v)	105318 (BZG 1652v)	105324 (BZG 1653v)	105330 (BZG 1655v)	1/1/1/1
		105313 (BZG 3231v)	105319 (BZG 3232v)		105331 (BZG 3235v)	1/1/ - /1
32	4	105314 (BZG 3241v)	105320 (BZG 3242v)	105326 (BZG 3243v)	105332 (BZG 3245v)	1/1/1/1
		105315 (BZG 3251v)	105321 (BZG 3252v)	105327 (BZG 3253v)	105333 (BZG 3255v)	1/1/1/1

Switched interlocked sockets vertical IP67 - 63 A

- Screw contacts.
- Flexible/rigid conductors 6 - 25/6 - 35 mm².



105408

Complies with standards: IEC 60309-1, -4
STN EN 60309-1, -4
Material: PA6, ABS
Surface treatment contacts: nickel-plated brass
Operating temperature: -25 °C to +55 °C

Amp.	Poles	110 V~ 50/60 Hz	230 V~ 50/60 Hz	400 V~ 50/60 Hz	500 V~ 50/60 Hz	Pkg. (pcs.)
		4h	3p=6h 4p+5p=9h	3p=9h 4p+5p=6h	7h	
63	3	105400 (BZG 6331v)	105403 (BZG 6332v)	105406 (BZG 6333v)	105409 (BZG 6335v)	1/ 1/ 1/ 1
		105401 (BZG 6341v)	105404 (BZG 6342v)	105407 (BZG 6343v)	105410 (BZG 6345v)	1/ 1/ 1/ 1
63	5	105402 (BZG 6351v)	105405 (BZG 6352v)	105408 (BZG 6353v)	105411 (BZG 6355v)	1/ 1/ 1/ 1

Switched interlocked sockets vertical IP67 - 125 A

- Screw contacts.
- Flexible/rigid conductors 16 - 50/16 - 50 mm².



105458

Complies with standards: IEC 60309-1, -4
STN EN 60309-1, -4
Material: PA6, ABS
Surface treatment contacts: nickel-plated brass
Operating temperature: -25 °C to +55 °C

Amp.	Poles	110 V~ 50/60 Hz	230 V~ 50/60 Hz	400 V~ 50/60 Hz	500 V~ 50/60 Hz	Pkg. (pcs.)
		4h	3p=6h 4p+5p=9h	3p=9h 4p+5p=6h	7h	
125	3	105450 (BZG 12531v)	105453 (BZG 12532v)		105459 (BZG 12535v)	1/ 1/ - / 1
		105451 (BZG 12541v)	105454 (BZG 12542v)	105457 (BZG 12543v)	105460 (BZG 12545v)	1/ 1/ 1/ 1
125	5	105452 (BZG 12551v)	105455 (BZG 12552v)	105458 (BZG 12553v)	105461 (BZG 12555v)	1/ 1/ 1/ 1



Switched interlocked sockets vertical IP67 - 16 A/32 A

Amp	Poles	Ord. No.	Dimensions (mm)				
			A	B	C	D	E
16	3	105310, 105316, 105328*	180	90	109/115*	140	52/60*
16	4	105311, 105317, 105323, 105329*	180	90	112/117*	140	50/60*
16	5	105312, 105318, 105324, 105330*	180	90	116/118*	140	52/60*
32	3	105313, 105319, 105331*	180	90	118/123*	140	50/60*
32	4	105314, 105320, 105326, 105332*	180	90	118/123*	140	52/60*
32	5	105315, 105321, 105327, 105333*	180	90	120/124*	140	50/60*

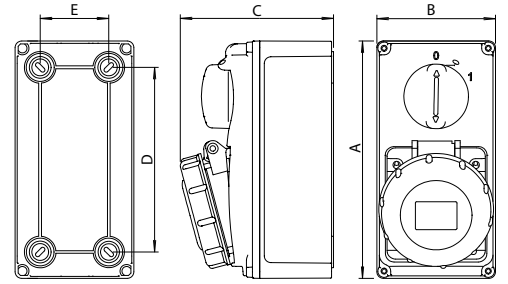

Switched interlocked sockets vertical IP67 - 63 A

Amp	Poles	Ord. No.	Dimensions (mm)						
			A	B	C	D	E	F	G
63	3	105400, 105403, 105406, 105409	262	162	195	240	140	11	310
63	4	105401, 105404, 105407, 105410	262	162	195	240	140	11	310
63	5	105402, 105405, 105408, 105411	262	162	195	240	140	11	310

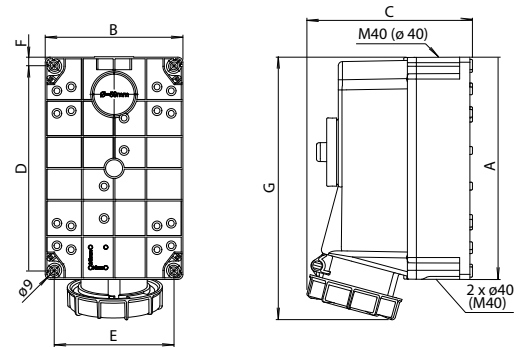

Switched interlocked sockets vertical IP67 - 125 A

Amp	Poles	Ord. No.	Dimensions (mm)					
			A	B	C	D	E	F
125	3	105450, 105453, 105459	520	222	208	505	201	547
125	4	105451, 105454, 105457, 105460	520	222	208	505	201	547
125	5	105452, 105455, 105458, 105461	520	222	208	505	201	547

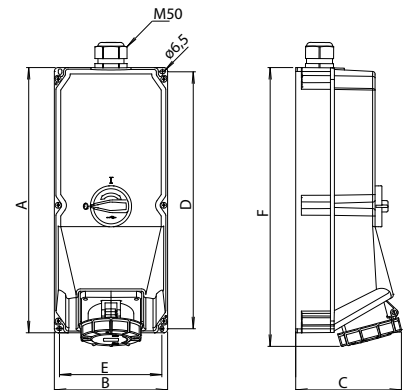

Protection caps for inlets and plugs - IP67

- To ensure coverage unconnected sockets and plugs.
- Colour: grey.

Complies with standards: IEC 60309-1, -2; STN EN 60309-1, -2
Material: PC/ABS, ABS, PA6 (Ord. No. 105706)
Operating temperature: -25 °C to +55 °C



105701

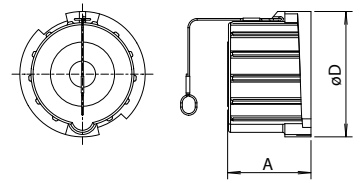

Amp	Poles	Ord. No.	Pkg. (pcs.)	Dimensions (mm)		
				A	Ø D	cord length
16	3	105700 (ND 105-0757)	60	39,5	60	250
16	4	105701 (ND 16CPG1)	16	39,5	68	250
16	5	105702 (ND 16CPG2)	10	40	80	220
32	3, 4	105703 (ND 32CPG1)	24	48	82	280
32	5	105704 (ND 32CPG2)	10	50	80	220
63	3, 4, 5	105705 (ND 63CPG1)	27	70,5	95,5	250
125	3, 4, 5	105706 (ND 125CPG1)	10	82	105	205

Protection caps for inlets and plugs - IP44

- To ensure coverage unconnected sockets and plugs.
- Colour: grey.
- Protective caps can be fixed to the body of plugs and inlets with double-sided adhesive tape on the triangular part at the end of the detachable plastic cord. (except ord. No. 105720 - without plastic cord).

Complies with standards: IEC 60309-1, -2; STN EN 60309-1, -2
Material: ABS, TPE/PP (Ord. No. 105720)
Operating temperature: -25 °C to +55 °C



105721

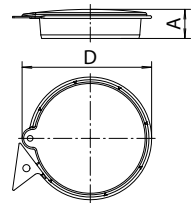

Amp	Poles	Ord. No.	Pkg. (pcs.)	Dimensions (mm)	
				A	D
16	3	105720 (KV 1632)	10	15	56
16	4	105721 (KV 1643)	24	16,1	54,7
16	5	105722 (KV 1653)	24	16,2	62,1
32	3, 4	105723 (KV 3243)	24	16,2	63,3
32	5	105724 (KV 3253)	30	16,4	70

Protection caps for socket - IP67

- To ensure coverage unconnected sockets and plugs.
- Colour: grey.

Complies with standards: IEC 60309-1, -2; STN EN 60309-1, -2
Material: ABS
Operating temperature: -25 °C to +55 °C



105731

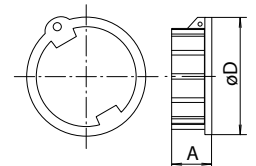

Amp	Poles	Ord. No.	Pkg. (pcs.)	Dimensions (mm)	
				A	Ø D
16	3	105730 (ND 16CZG1)	29	16,5	78
32	3, 4	105731 (ND 32CZG1)	1	19,5	94
63	3, 4, 5	105732 (ND 63CZG1)	20	22,5	111,5

Mounting frame with mounting spacing 60 x 60 mm or 60 x 70 mm

- For built-in sockets/inlets.
- For installation use a Ø4 mm screw for plastics.
- Ord. No. 105760 for: 104076, 104083, 104084, 104079, 104085, 104087, 104174, 104177, 104264, 104267, 104310 až 104315, 104329 až 104333, 104400, 104402, 104404 až 104406, 104408, 104410, 104411, 104414, 104416, 104417.

Complies with standards: IEC 60309-1, -2; STN EN 60309-1, -2
Material: PA6
Operating temperature: -25 °C to +55 °C



105760

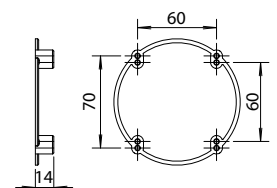

Ord. No.	Pkg. (pcs.)	For separation (mm)
105760 (ND 105-2177)	200	60 x 60 / 60 x 70



Mounting frame with a mounting spacing of 38 x 38 mm

- For built-in sockets/inlets
- For installation use a $\varnothing 4$ mm screw for plastics.
- Ord. No. 105761 for: Ord. No. 103750 to 103759, 103790 to 103793, 103830.

Complies with standards: IEC 60309-1, -2; STN EN 60309-1, -2
Material: PC/ABS, ABS, PA6 (Ord. No. 105706)
Operating temperature: -25 °C to +55 °C



105761

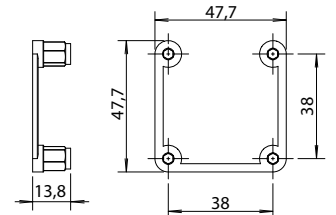

Ord. No.	Pkg. (pcs.)
105761 (ND 105-2677)	120

For spacing (mm)
38 x 38

Sealing IP54 for house sockets

- To be used for house sockets mounting on uneven surfaces for IP 54.

Complies with standards: IEC 60309-1, -2; STN EN 60309-1, -2
Material: rubber
Operating temperature: -25 °C to +55 °C



105770

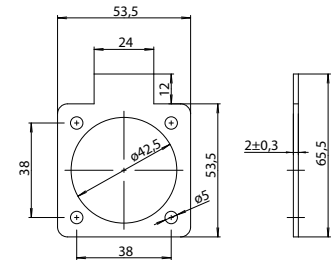

Ord. No.	Pkg. (pcs.)
105770 (ND 143-0245)	20

Connecting gland with Pg16 thread

- For connecting of two or more wall sockets with on wall box, ord. No 102347 to 102361.

Complies with standards: IEC 60309-1, -2; STN EN 60309-1, -2
Material: ABS
Operating temperature: -25 °C to +55 °C



105780

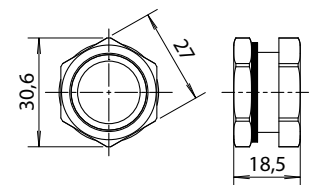

Ord. No.	Pkg. (pcs.)
105780 (SPg 16)	5

Connecting part PR 10

- For connecting of two or more wall sockets with on wall box, ord. No 102257 to 102271.

Complies with standards: IEC 60309-1, -2; STN EN 60309-1, -2
Material: ABS
Operating temperature: -25 °C to +55 °C



105790

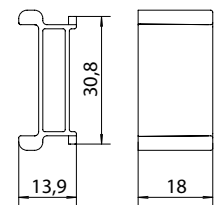

Ord. No.	Pkg. (pcs.)
105790 (PR 10)	100



DISTRIBUTION BOXES

CONTENTS

Distribution boxes	66 - 71
8, 4 and 0-modules distribution boxes ROS Mini - IP44	72 - 79
Distribution boxes Micro ROSP - IP54, ROSPG - IP67	80 - 83
Distribution boxes Micro with switch – IP44	84
Compact distribution boxes with straight inlet ROP - IP44	85 - 86
Hang-on distribution boxes ROK IP54	87
4-modules distribution boxes ROS 4- IP44	88
Distribution boxes with switch ROS 4/V-IP44	89
6-modules distribution boxes ROS 6 - IP54, ROS M6 - IP54/IP65	90 - 95
7-modules distribution boxes with switch ROS 7 - IP54	96 - 98
11-modules distribution boxes ROS 11 - IP54	99 - 106
16-modules distribution boxes ROS 11 - IP54/IP66	107 - 109
Building distribution boxes 11, 12, 16 and 24 modules- IP 44, IP54, IP65, IP66	110 - 115
Semi-assemblies and spare parts	116 - 119

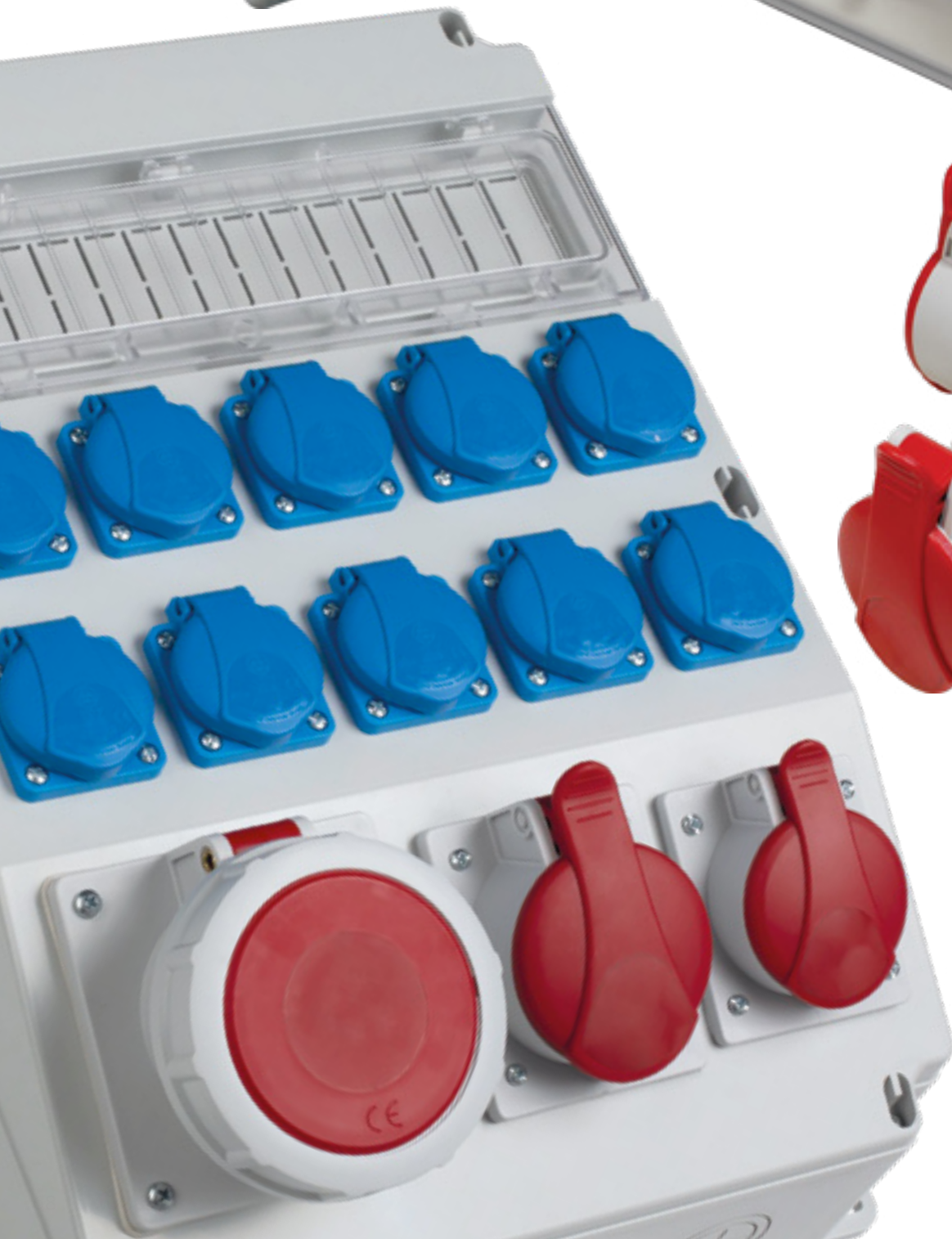
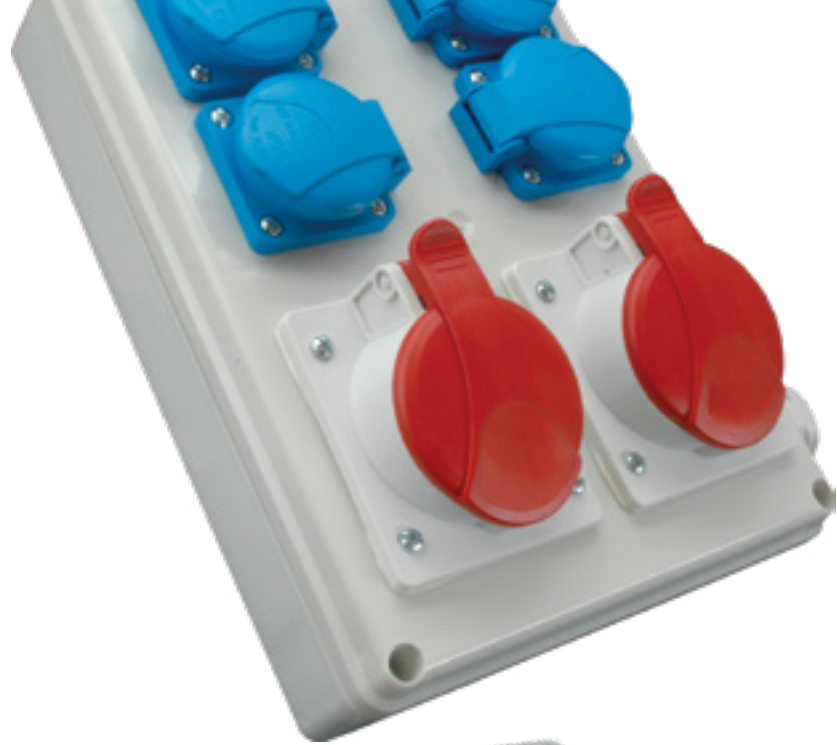

Distribution boxes

Distribution boxes belong to the group of low voltage covered distributors according to STN EN 61439-3, -1, operable also by unqualified persons (referred to as DBO). They may be used at building sites, in residential buildings, houses and industrial zones.

They are designed to be mounted mainly on vertical wall, but may also be used as portable (the handle is placed in the upper part of the distribution box), or are fixed to a metal frame stand. The current standard catalog offer contains more than 600 types and combinations of ROS, which are designed for both internal and external use within the temperature range from -25 °C to +55 °C. Distribution boxes do not require any maintenance after installation.

OVERVIEW OF DISTRIBUTION BOXES

- ROS Mini – 8, 4 and 0-modules distribution boxes IP44
- ROSP, ROSPG – Distribution boxes Micro IP54 and IP67
 - Distribution boxes Micro with switch IP44
 - VPS – Inlets with switch IP44
- ROP – Compact distribution boxes with straight inlet IP44
 - ROK – Hang-on distribution boxes ROK IP54
 - ROS 4 – 4-modules distribution boxes IP44
 - ROS-4/V – Distribution boxes with switch IP44
- ROS 6, ROS 7, ROS 11 – 6, 7 and 11-modules distribution boxes IP54
 - ROS M6 – 6- modules distribution boxes IP54 and IP65
 - ROS 16 – 16-modules distribution boxes IP54 and IP66
 - ROS 11S – 11-modules distribution boxes on stand IP54
- ROS 12SD – 12-modules portable distribution boxes with handle IP44
 - ROS 12S, ROS 24S – 12 and 24-modules distribution boxes on stand IP54 and IP65

Distribution boxes can be equipped with single-phase and three-phase MCBs, RCCBs, terminal blocks, sealing glands, industrial three-phase inlets or plugs with connecting cable and sockets 16 A, 32 A and 63 A. They also allow the installation of a single-phase or three-phase one-tariff electricity meter mounted on a DIN rail.

BASIC SPECIFICATION

The housings are resistant to excessive heat and burning (650 °C glow wire test) and are molded from plastics with mechanical resistance in the range of IK08, IK09, IK10. Distribution boxes can be mounted on materials of Class A1 and A2,

Distribution boxes are supplied in the following specifications:

- degree of protection: IP44, IP54, IP65, IP66, IP67
- nominal current InA: 16 A, 32 A, 40 A or 63 A
- nominal working voltage Un: 400 V~, 250 V~, 50/60 Hz
- mechanical resistance of boxes: IK06, IK07, IK08, IK09, IK10

The power supply cable may only be installed by an appropriately qualified person. Distribution boxes are equipped with breakers of the rupturing capacity of 10 kA.

Regarding fusing outside of the distribution box it is recommended to use the MCB with breaking capacity of 10 kA and with the current value equivalent to the current InA stated on the distribution box label.

We also offer distribution boxes fitted with MCB window but without MCBs, fully pre-wired to connect own MCBs of a specific brand according to customer's preferences and in accordance with the recommended and enclosed electrical connection scheme.

WE DISTINGUISH SWITCHBOARDS WITHOUT MCBs, RCCBS AS FOLLOWS:

Fully pre-wired distribution boxes - sign „/x“

Distribution box without the circuit breakers, yet fully equipped with wires to connect the circuit breakers according to the recommended and attached connection scheme. The socket outlets are wired separately for particular connection to the individual circuit breakers and also to the N and PE bridges. Circuit breakers must be used.

Economically pre-wired distribution boxes - sign „/A“ (e.g. 200060 ROS-I 1601 A)

Protected distribution box without the circuit breakers with prepared wires to connect the circuit breakers according to the recommended and attached connection scheme. The socket outlets are not wired separately for particular connection to the individual circuit breakers, they are looped together. Circuit breakers must be used.

Portable distribution boxes ROS 12S and ROS 24S are characterized by a robust construction. Mechanical resistance of the housing is IK 10 and boxes are produced from glass fiber reinforced polyester. Distribution boxes fitted with 4-pole sockets are determined for symmetrical loads only.

INDIVIDUAL CONFIGURATION OF DISTRIBUTION BOXES

Except of distribution boxes in the catalog which are most commonly used in practice we are able to supply the any other atypical designs in acceptable combinations according to the customer's individual specifications.



ROS MINI – 8, 4 AND 0 -MODULES DISTRIBUTION BOXES IP44

Suitable for the connecting of 3-phase and 1-phase electrical appliances. The above types of distribution boxes without handle have been designed to be part of fixed wiring only, with handle as part of mobile wiring. The inlet terminal board is dimensioned for the power supply cable of the maximum of 5 x 4 mm², the power supply cable must be protected for the nominal current value showed on the label.

- degree of protection: IP44
- nominal current: 16 A, 32 A
- nominal working voltage: 400 V~, 250 V~, 50/60 Hz
- mechanical resistance of boxes: IK10

ROSP, ROSPG – DISTRIBUTION BOXES MICRO IP54 AND IP67

Suitable for the connection of 3-phase as well as 1-phase devices. 32 A variants are supplied with 2 x tube fuse F10 A/250 V for protection for single-phase socket. Distribution boxes with handle have been designed to be part of mobile wiring. There is a possibility to use it in exterior as well as interior environment, block of flats and houses, building sites and also in industrial zones.

Box contains cable gland Pg16 for 16 A and Pg21 for 32 A.

- degree of protection: IP 54, IP 67
- nominal current: 16 A, 32 A
- nominal working voltage: 400 V~, 250 V~, 50/60 Hz
- mechanical resistance of boxes: IK10

VZS – DISTRIBUTION BOXES MICRO WITH SWITCH IP44

Suitable for connection if 3-phase and 1-phase electric devices with possibility to switch of by switch

32 A/4P/5P. 32 A variants are supplied along with tube fuse F10H/250V and protection of 1-phase socket.

- degree of protection: IP44
- nominal current: 16 A, 32 A
- nominal working voltage: 400 V~, 250 V~, 50/60 Hz
- mechanical resistance of boxes: IK10

VPS – INLETS WITH SWITCH IP44

They are designed for supplying electric current through an extension cable to 3-phase 16 A and 32 A machines and devices (circular saws, mixers, etc.) with the possibility of switching off the device by a supplied 16 A / 5P or 32 A / 5P switch.

- degree of protection: IP44
- nominal current: 16 A, 32 A
- nominal working voltage: 400 V~, 250 V~, 50/60 Hz
- mechanical resistance of boxes: IK10

ROP – COMPACT DISTRIBUTION BOXES WITH STRAIGHT INLET IP44

A series of compact distribution boxes with IP44 protection. They are equipped with a straight industrial inlet 16 A / 32 A / 5P / 4P / 400 V at the input. They offer a wide combination of the three available outputs and the offer includes 2 types in 32 A and 8 types in 16 A power. These compact distribution boxes with an inlet can be used both outdoors and indoors, in residential buildings and houses, on construction sites and also in industrial plants.

- degree of protection: IP44
- nominal current: 16 A, 32 A
- nominal working voltage: 400 V~, 250 V~, 50/60 Hz
- mechanical resistance of boxes: IK06

ROK – HANG-ON DISTRIBUTION BOXES ROK IP54

ROK Hang-on distribution boxes are designed for hanging in space and can be used outdoors as well as indoors, in residential buildings and houses, on construction sites and in industrial plants. They are equipped with a straight industrial inlet 16 A / 32 A / 5P 400 V in the standard version (including the possibility of reversing 5P inlets), also with sealing metric gland M25, M35 and four outputs with the possibility of combination with three-phase sockets 32 A/16 A/5P/400 V and single-phase sockets 16 A/400 V, 250 V/16 A according to user requirements. The back side may be equipped with a quick connector and a hose insertion for compressed air distribution. The 700 mm long chain with spring hooks to fix the distribution box is supplied separately.

- degree of protection: IP54
- nominal current: 16 A, 32 A
- nominal working voltage: 400 V~, 250 V~, 50/60 Hz
- mechanical resistance of boxes: IK07

ROS 4 – 4-MODULES DISTRIBUTION BOXES IP44

They represent a group of compact distribution boxes, which are suitable for connecting of three-phase and single-phase electrical appliances with the possibility of protection. Possibility of use in exterior and interior, in residential buildings and houses, on construction sites and also in industrial plants. They are produced in versions as protected and without MCBs, but fully pre-wired.

- degree of protection: IP44
- nominal current: 16 A, 32 A
- nominal working voltage: 400 V~, 250 V~, 50/60 Hz
- mechanical resistance of boxes: IK08

ROS-4/V – DISTRIBUTION BOXES WITH SWITCH IP44

Suitable for connection if 3-phase and 1-phase electric devices with possibility to switch of by switch- 32A variants are supplied along with tube fuse F10 A/250V and protection of 1-phase socket. There is a possibility to use it in exterior as well as interior environment, block of flats and houses, building sites and also in industrial zones. Box contains cable gland for sealing input cable.

- degree of protection: IP44
- nominal current: 16 A, 32 A
- nominal working voltage: 400 V~, 250 V~, 50/60 Hz
- mechanical resistance of boxes: IK08

ROS 6, ROS 7, ROS 11 – 6, 7 AND 11-MODULES DISTRIBUTION BOXES IP54

Protected

The recommended distribution box input cable is 5 x 6 mm² and it must be connected via a three-phase 32A breaker parameter C. Individual types are equipped with three-phase and single-phase sockets, breakers, and cable gland M32.

Without MCBs, fully pre-wired

The recommended distribution box input cable is 5x6 mm², the maximum total current stated on the label. The power input cable must be connected as follows: connect phase conductors via the breaker, which will be mounted by users themselves according to their own choice, to the inlet terminal board, the size of the breakers must be sufficient to enable protection with respect to the maximum current stated on the label. Connect PE and N conductors directly to inlet terminal.

- the maximum total current: 32 A
- degree of protection: IP 54
- nominal current: 16 A, 32 A



- nominal working voltage: 400 V~, 250 V~, 50 Hz
 - mechanical resistance of boxes: IK 10

Types with a current protector are provided in sizes ROS 6 and ROS 11. They are normally equipped with a current protector for the fault current $I\Delta n \leq 30$ mA.

ROS M6 – 6-MODULES DISTRIBUTION BOXES IP54 AND IP65

The distribution box cover is pressed from halogen free thermoplastic. Distribution boxes have been designed for both internal and external use within the temperature range from -25°C to $+55^{\circ}\text{C}$. The power supply cable may only be installed by an appropriately qualified person. They are all supplied in the following specifications:

- degree of protection: IP54 or IP65
 - nominal current: 16 A, 32 A, 63 A
- nominal working voltage: 400 V~, 250 V~, 50/60 Hz
 - mechanical resistance of boxes: IK09
 - doubled insulation

ROS 16 – 16-MODULES DISTRIBUTION BOXES IP54 AND IP66

- Protected MCB/RCCB.
 - Unprotected - pre-wired.
- ROS 16/FI - Standard = distribution boxes are fully equipped with the necessary MCBs and RCCBs.
 - ROS 16/I - Economic = basic number MCBs.
- ROS 16/x - Unprotected = without MCBs, precabing ready for installation MCBs according to the Standard version.

Benefits:

- The most compact design in 16 modules series of distribution boxes on the market (H x W x D = 450 x 328 x 136 mm) with ergonomically sloped surface.
- Available in combinations with CEE 63 A sockets, 63 A main switch or 63 A panel plug for mutual looping facility of more ROS 16 on the site.
- 63 standard combinations kept on stock and over 2400 combinations of inlets, outlets and MCB/RCCB protection available on request.
 - Suitable for construction sites, industrial distributions and residential buildings.

PARAMETERS:

- Low voltage distribution on-wall boxes from highly durable ABS material with extra thick walls (4 mm),
 - Mechanical resistance of boxes: IK10
 - MCB/RCCB-protected
 - Non-protected – pre-wired
 - Pre-injected recessed circles for cable glands M25; M32; M40; M50
 - Self extinguishing: 650 °C - resistant against overheating and burning
- Ingress protection degree available in IP54 and IP66
 - In compliance with EN 61439-1, -3

ROS 11S – 11-MODULES DISTRIBUTION BOXES ON STAND IP54

Portable distribution boxes are designed mainly for internal and external use. They are offered with an M32 gland for connecting the supply cable, or with a supply cable with a length of 2 m and a plug 32 A / 5P / 400 V. They are all supplied in the following specifications:

- degree of protection: IP54
- nominal current: 32 A
- nominal working voltage: 400 V~, 250 V~, 50/60 Hz
- mechanical resistance of boxes: IK10

ROS 12SD – 12-MODULES PORTABLE DISTRIBUTION BOXES WITH HANDLE IP4

Suitable for the connection of 3-phase as well as 1-phase consumers. Distribution box with handle have been designed to be part of mobile wiring. There is a possibility to use it in exterior as well as interior environment, block of flats and houses, building sites and also in industrial zones. They are equipped by MCBs as well as current RCCBs.

Dimensions (mm) 194 x 384 x 230 (width x height x depth)

- degree of protection: IP44
- nominal current: 16 A, 32 A
- nominal working voltage: 400 V~, 250 V~, 50/60 Hz
- mechanical resistance of boxes: IK08

ROS 12S, ROS 12SG, ROS 24S, ROS 24SG – 12 AND 24-MODULES DISTRIBUTION BOXES ON STAND IP54 AND IP65

The group includes two distribution boxes and option of modular superstructures with a maximum of 12 or 24 modules with 63 A three-phase switch. The distribution box cover is pressed from polyester and strengthened by glass fibre. Distribution boxes have been designed for external use. They are all supplied in the following specifications:

- degree of protection: IP 54, IP 65
- nominal current: 16 A, 32 A
- nominal working voltage: 400 V~, 250 V~, 50 Hz
- mechanical resistance of boxes: IK 10
- resistance to pressure: 200 N/mm²
- heat and combustion resistance: UL94: V0.

The input cable may only be installed by an appropriately qualified person. Portable distribution boxes with a holder can be equipped with breakers, current protector 16 A, 32 A sockets. We offer four-pole and five-pole modifications with predefined fitting of devices in two sizes of the boxes. Portable distribution boxes with a holder can be used where the connection of more devices with 32 A and 16 A electricity use is needed to the distribution board while being protected.

Used brands of circuit MCBs and RCCB

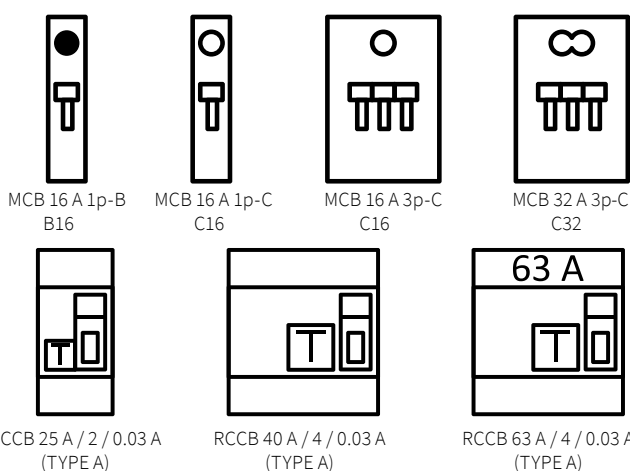

Mini distribution boxes ROS 8 IP44 with RCCB

- Designed for wall mounting as part of a fixed wiring.
- Distribution boxes do not require any maintenance after installation.
- Cover resistant against excessive heat and fire (650 °C glow wire test).
- Dimensions 260 x 190 x 106 mm (h x w x d).

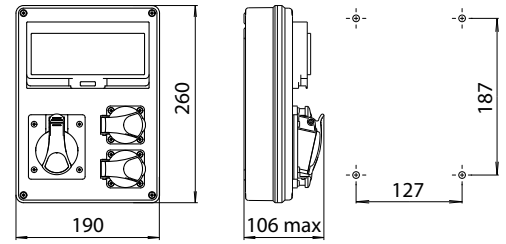

200006

Complies with standards: STN EN 61439-1, STN EN 61439-3
 Mechanical resistance of box: IK10
 Degree of protection: IP44
 Material: ABS
 Nominal working voltage: 400 V~, 250 V~, 50/60 Hz
 Operating temperature: -25 °C to +55 °C

Ord. No. (Type)	Layout	CEE 400 V 5P		CEE 400 V 4P		250 V		Protection		Connection	InA	Pkg (pcs.)
		32 A	16 A	32 A	16 A	16 A Fr	16 A Sch	RCCB	MCBs			
200000 (ROS-FI 1600 /C)		-	-	-	-	6	-	1xRCCB 40 A/4/0,03 A (Type A) Only 250 V/16 A sockets are connected with RCCB.	3xMCB 16 A 1P-C	5 x 4 mm ² Pg 21	InA 16 A	5
200001 (ROS-FI 1600 /C/S)		-	-	-	-	-	6					
200002 (ROS-FI 1603)		-	1	-	-	2	-	1xRCCB 40 A/4/0,03 A (Type A)	1xMCB 16 A 3P-C 1xMCB 16 A 1P-C	5 x 4 mm ² Pg 21	InA 32 A	5
200003 (ROS-FI 1603 /S)		-	-	-	-	-	2					
200004 (ROS-FI 3203)		1	-	-	-	2	-	1xRCCB 40 A/4/0,03 A (Type A)	1xMCB 32 A 3P-C 1xMCB 16 A 1P-C	5 x 4 mm ² Pg 21	InA 32 A	5
200005 (ROS-FI 3203 /S)		-	-	-	-	-	2					
200006 (ROS-FI 1602 /C)		-	-	-	1	2	-	1xRCCB 25 A/2/0,03 A (Type A) Only 250 V/16 A sockets are connected with RCCB.	1xMCB 16 A 3P-C 1xMCB 16 A 1P-C	5 x 4 mm ² Pg 21	InA 32 A	5
200007 (ROS-FI 1602 /C/S)		-	-	-	-	-	2					
200008 (ROS-FI 3202 /C)		-	-	1	-	2	-	1xRCCB 25 A/2/0,03 A (Type A) Only 250 V/16 A sockets are connected with RCCB.	1xMCB 32 A 3P-C 1xMCB 16 A 1P-C	5 x 4 mm ² Pg 21	InA 32 A	5
200009 (ROS-FI 3202 /C/S)		-	-	-	-	-	2					

InA = Rated current of switchgear and control gear assembly

Mini distribution boxes ROS 8 IP44 without MCBs, economically pre-wired

- Distribution boxes without MCBs, other product features identical to **Mini distribution boxes ROS 8 IP44 with RCCBs**.

Ord. No. (Type)	Layout	CEE 400 V 5P		CEE 400 V 4P		250 V		Protection		Connection	InA	Pkg (pcs.)
		32 A	16 A	32 A	16 A	16 A Fr	16 A Sch	RCCB	MCBs			
200020 (ROS-FI 1600 A)		-	-	-	-	6	-	-	-	5 x 2,5 mm ² Pg 21	InA 16 A	5
200021 (ROS-FI 1600 A/S)		-	-	-	-	-	6					

InA = Rated current of switchgear and control gear assembly







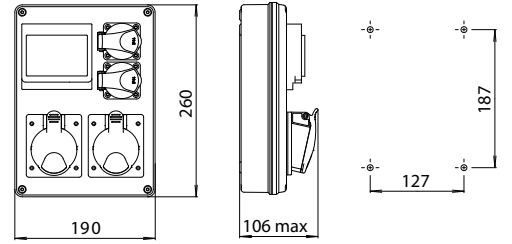



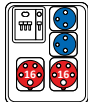

Mini distribution boxes ROS 4 IP44 protected

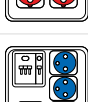
- Designed for wall mounting as part of a fixed wiring.
- Distribution boxes do not require any maintenance after installation.
- Cover resistant against excessive heat and fire (650 °C glow wire test).
- Dimensions 260 x 190 x 106 mm (h x w x d).



Complies with standards: STN EN 61439-1, STN EN 61439-3
 Mechanical resistance of box: IK10
 Degree of protection: IP44
 Material: ABS
 Nominal working voltage: 400 V~, 250 V~, 50/60 Hz
 Operating temperature: -25 °C to +55 °C

200036

Ord. No. (Type)	Layout	CEE 400 V 5P		CEE 400 V 4P		250 V		Protection		Connection	InA	Pkg (pcs.)
		32 A	16 A	32 A	16 A	16 A Fr	16 A Sch	RCCB	MCBs			
200030 (ROS-I 1601)		-	2	-	-	2	-	-	1xMCB 16 A 3P-C 1xMCB 16 A 1P-C	5 x 4 mm ² Pg 21	InA 32 A	5
200031 (ROS-I 1601/S)		-	2	-	-	-	2	-	-	-	-	-
200032 (ROS-I 1603)		1	1	-	-	2	-	-	1xMCB 16 A 3P-C 1xMCB 16 A 1P-C	5 x 4 mm ² Pg 21	InA 32 A	5
200033 (ROS-I 1603/S)		-	2	-	-	-	2	-	-	-	-	-
200034 (ROS-I 3201)		2	-	-	-	2	-	-	1xMCB 32 A 3P-C 1xMCB 16 A 1P-C	5 x 4 mm ² Pg 21	InA 32 A	5
200035 (ROS-I 3201/S)		-	2	-	-	-	2	-	-	-	-	-
200036 (ROS-I 1600)		-	-	-	2	2	-	-	1xMCB 16 A 3P-C 1xMCB 16 A 1P-C	5 x 4 mm ² Pg 21	InA 32 A	5
200037 (ROS-I 1600/S)		-	2	-	-	-	2	-	-	-	-	-
200038 (ROS-I 1602)		-	-	1	1	2	-	-	1xMCB 16 A 3P-C 1xMCB 16 A 1P-C	5 x 4 mm ² Pg 21	InA 32 A	5
200039 (ROS-I 1602/S)		-	2	-	-	-	2	-	-	-	-	-
200040 (ROS-I 3200)		-	-	2	-	2	-	-	1xMCB 32 A 3P-C 1xMCB 16 A 1P-C	5 x 4 mm ² Pg 21	InA 32 A	5
200041 (ROS-I 3200/S)		-	2	-	-	-	2	-	-	-	-	-

InA = Rated current of switchgear and control gear assembly





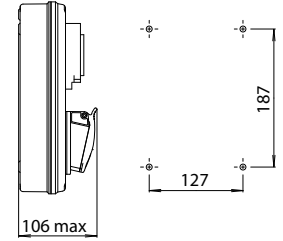
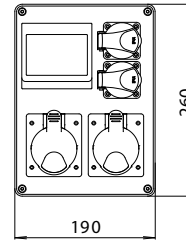

Mini distribution boxes ROS 4 IP44 without MCBs, economically pre-wired

- Designed for wall mounting as part of a fixed wiring.
- Distribution boxes do not require any maintenance after installation.
- Cover resistant against excessive heat and fire (650 °C glow wire test).
- Dimensions 260 x 190 x 106 mm (h x w x d).

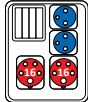
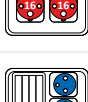
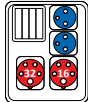

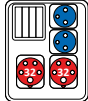
Complies with standards: STN EN 61439-1, STN EN 61439-3
 Mechanical resistance of box: IK10
 Degree of protection: IP44
 Material: ABS
 Nominal working voltage: 400 V~, 250 V~, 50/60 Hz
 Operating temperature: -25 °C to +55 °C

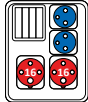
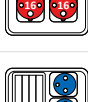
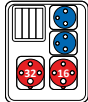
200066

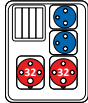
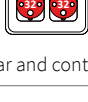
Ord. No. (Type)	Layout	CEE 400 V 5P		CEE 400 V 4P		250 V		Protection		Connection	InA	Pkg (pcs.)
		32 A	16 A	32 A	16 A	16 A Fr	16 A Sch	RCCB	MCBs			
200060 (ROS-I 1601 A)		-	2	-	-	2	-	-	-	5 x 4 mm ² Pg 21	InA 32 A	5
200061 (ROS-I 1601 A/S)		-	2	-	-	-	2	-	-	5 x 4 mm ² Pg 21	InA 32 A	5
200062 (ROS-I 1603 A)		1	1	-	-	2	-	-	-	5 x 4 mm ² Pg 21	InA 32 A	5
200063 (ROS-I 1603 A/S)		1	1	-	-	-	2	-	-	5 x 4 mm ² Pg 21	InA 32 A	5
200064 (ROS-I 3201 A)		2	-	-	-	2	-	-	-	5 x 4 mm ² Pg 21	InA 32 A	5
200065 (ROS-I 3201 A/S)		2	-	-	-	-	2	-	-	5 x 4 mm ² Pg 21	InA 32 A	5
200066 (ROS-I 1600 A)		-	-	-	2	2	-	-	-	5 x 4 mm ² Pg 21	InA 32 A	5
200067 (ROS-I 1600 A/S)		-	-	-	2	-	2	-	-	5 x 4 mm ² Pg 21	InA 32 A	5
200068 (ROS-I 1602 A)		-	-	1	1	2	-	-	-	5 x 4 mm ² Pg 21	InA 32 A	5
200069 (ROS-I 1602 A/S)		-	-	1	1	-	2	-	-	5 x 4 mm ² Pg 21	InA 32 A	5
200070 (ROS-I 3200 A)		-	-	2	-	2	-	-	-	5 x 4 mm ² Pg 21	InA 32 A	5
200071 (ROS-I 3200 A/S)		-	-	2	-	-	2	-	-	5 x 4 mm ² Pg 21	InA 32 A	5

InA = Rated current of switchgear and control gear assembly



Mini distribution boxes ROS IP44 unprotected

- Designed for wall mounting as part of a fixed wiring.
- Distribution boxes do not require any maintenance after installation.
- Cover resistant against excessive heat and fire (650 °C glow wire test).
- Dimensions 260 x 190 x 106 mm (h x w x d).

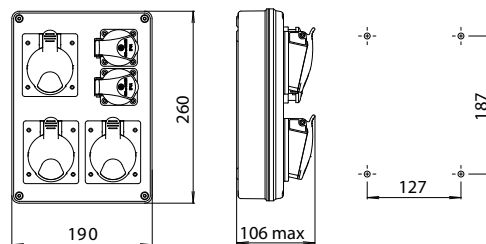

Complies with standards: STN EN 61439-1, STN EN 61439-3
 Mechanical resistance of box: IK10
 Degree of protection: IP44
 Material: ABS
 Nominal working voltage: 400 V~, 250 V~, 50/60 Hz
 Operating temperature: -25 °C to +55 °C

200084

Ord. No. (Type)	Layout	CEE 400 V 5P		CEE 400 V 4P		250 V		Protection		Connection	InA	Pkg (pcs.)
		32 A	16 A	32 A	16 A	16 A Fr	16 A Sch	RCCB	MCBs			
200080 (ROS 1601)		-	4	-	-	-	-	-	-	5 x 2,5 mm ² Pg 16	InA 16 A	5
200082 (ROS 1603)		-	3	-	-	2	-	-	-	5 x 2,5 mm ² Pg 21	InA 16 A	5
200083 (ROS 1603/S)		-	3	-	-	-	2	-	-	5 x 2,5 mm ² Pg 21	InA 16 A	5
200084 (ROS 1605)		-	2	-	-	4	-	-	-	5 x 2,5 mm ² Pg 21	InA 16 A	5
200085 (ROS 1605/S)		-	2	-	-	-	4	-	-	5 x 2,5 mm ² Pg 21	InA 16 A	5
200086 (ROS 1607)		2x CEE 230 V 16 A 3P				4	-	-	-	5 x 2,5 mm ² Pg 16	InA 16 A	5
200087 (ROS 1607/S)		2x CEE 230 V 16 A 3P				-	4	-	-	5 x 2,5 mm ² Pg 16	InA 16 A	5
200088 (ROS 3201)		4	-	-	-	-	-	-	-	5 x 4 mm ² Pg 21	InA 32 A	5
200090 (ROS 1600)		-	-	-	4	-	-	-	-	4 x 2,5 mm ² Pg 16	InA 16 A	5
200092 (ROS 1602)		-	-	-	3	2	-	-	-	5 x 2,5 mm ² Pg 21	InA 16 A	5
200093 (ROS 1602/S)		-	-	-	3	-	2	-	-	5 x 2,5 mm ² Pg 21	InA 16 A	5
200094 (ROS 1604)		-	-	-	2	4	-	-	-	5 x 2,5 mm ² Pg 21	InA 16 A	5
200095 (ROS 1604/S)		-	-	-	2	-	4	-	-	5 x 2,5 mm ² Pg 21	InA 16 A	5
200096 (ROS 3200)		-	-	4	-	-	-	-	-	4 x 4 mm ² Pg 21	InA 32 A	5

InA = Rated current of switchgear and control gear assembly





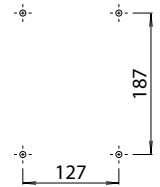
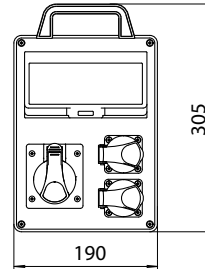

Mini distribution boxes ROS 8 IP44 with RCCB, handle

- Distribution boxes with handle have been designed to be part of mobile wiring.
- Distribution boxes do not require any maintenance after installation.
- Cover resistant against excessive heat and fire (650 °C glow wire test).
- Dimensions 305 x 190 x 106 mm (h x w x d).

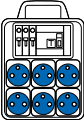

200126

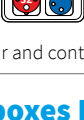
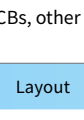
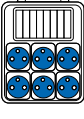

Complies with standards: STN EN 61439-1, STN EN 61439-3
 Mechanical resistance of box: IK10
 Degree of protection: IP44
 Material: ABS
 Nominal working voltage: 400 V~, 250 V~, 50/60 Hz
 Operating temperature: -25 °C to +55 °C

Ord. No. (Type)	Layout	CEE 400 V 5P		CEE 400 V 4P		250 V		Protection		Connection	InA	Pkg (pcs.)
		32 A	16 A	32 A	16 A	16 A Fr	16 A Sch	RCCB	MCBs			
200120 (ROS-FI 1600 D/C)		-	-	-	-	6	-	1xRCCB 40 A/4/0,03 A (Type A) Only 250 V/16 A sockets are connected with RCCB.	3xMCB 16 A 1P-C	5 x 4 mm ² Pg 21	InA 16 A	5
200121 (ROS-FI 1600 D/C/S)		-	-	-	-	-	6					
200122 (ROS-FI 1603 D)		-	1	-	-	2	-	1xRCCB 40 A/4/0,03 A (Type A)	1xMCB 16 A 3P-C 1xMCB 16 A 1P-C	5 x 4 mm ² Pg 21	InA 32 A	5
200123 (ROS-FI 1603 D/S)		-	-	-	-	-	2					
200124 (ROS-FI 3203 D)		1	-	-	-	2	-	1xRCCB 40 A/4/0,03 A (Type A)	1xMCB 32 A 3P-C 1xMCB 16 A 1P-C	5 x 4 mm ² Pg 21	InA 32 A	5
200125 (ROS-FI 3203 D/S)		-	-	-	-	-	2					
200126 (ROS-FI 1602 D/C)		-	-	-	1	2	-	1xRCCB 25 A/2/0,03 A (Type A) Only 250 V/16 A sockets are connected with RCCB.	1xMCB 16 A 3P-C 1xMCB 16 A 1P-C	5 x 4 mm ² Pg 21	InA 32 A	5
200127 (ROS-FI 1602 D/C/S)		-	-	-	-	-	2					
200128 (ROS-FI 3202 D/C)		-	-	1	-	2	-	1xRCCB 25 A/2/0,03 A (Type A) Only 250 V/16 A sockets are connected with RCCB.	1xMCB 32 A 3P-C 1xMCB 16 A 1P-C	5 x 4 mm ² Pg 21	InA 32 A	5
200129 (ROS-FI 3202 D/C/S)		-	-	-	-	-	2					

InA = Rated current of switchgear and control gear assembly

Mini distribution boxes ROS 8 IP44 without MCBs, economically pre-wired, handle

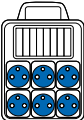
- Distribution boxes without MCBs, other product features identical to Mini distribution boxes ROS 8 IP44 with RCCB, handle

Ord. No. (Type)	Layout	CEE 400 V 5P		CEE 400 V 4P		250 V		Protection		Connection	InA	Pkg (pcs.)
		32 A	16 A	32 A	16 A	16 A Fr	16 A Sch	RCCB	MCBs			
200140 (ROS-FI 1600 D/A)		-	-	-	-	6	-	-	-	5 x 2,5 mm ² Pg 21	InA 16 A	5
200141 (ROS-FI 1600 D/A/S)		-	-	-	-	-	6					

InA = Rated current of switchgear and control gear assembly



DISTRIBUTION BOXES

4-modules distribution boxes Mini with handle

CONNECTING ENERGY



Mini distribution boxes ROS 4 IP44 protected, handle

- Distribution boxes with handle have been designed to be part of mobile wiring.
- Distribution boxes do not require any maintenance after installation.
- Cover resistant against excessive heat and fire (650 °C glow wire test).
- Dimensions 305 x 190 x 106 mm (h x w x d).



200162

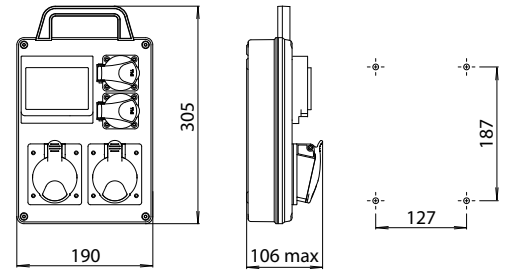

Complies with standards:	STN EN 61439-1, STN EN 61439-3
Mechanical resistance of box:	IK10
Degree of protection:	IP44
Material:	ABS
Nominal working voltage:	400 V~, 250 V~, 50/60 Hz
Operating temperature:	-25 °C to +55 °C

Ord. No. (Type)	Layout	CEE 400 V 5P		CEE 400 V 4P		250 V		Protection		Connection	InA	Pkg (pcs.)
		32 A	16 A	32 A	16 A	16 A Fr	16 A Sch	RCCB	MCBs			
200160 (ROS-I 1601 D)		-	2	-	-	2	-	-	1xMCB 16 A 3P-C 1xMCB 16 A 1P-C	5 x 4 mm ² Pg 21	InA 32 A	5
200161 (ROS-I 1601 D/S)		-	-	-	-	-	2	-	-	-	-	-
200162 (ROS-I 1603 D)		1	1	-	-	2	-	-	1xMCB 16 A 3P-C 1xMCB 16 A 1P-C	5 x 4 mm ² Pg 21	InA 32 A	5
200163 (ROS-I 1603 D/S)		-	-	-	-	-	2	-	-	-	-	-
200164 (ROS-I 3201 D)		2	-	-	-	2	-	-	1xMCB 32 A 3P-C 1xMCB 16 A 1P-C	5 x 4 mm ² Pg 21	InA 32 A	5
200165 (ROS-I 3201 D/S)		-	-	-	-	-	2	-	-	-	-	-
200166 (ROS-I 1600 D)		-	-	-	2	2	-	-	1xMCB 16 A 3P-C 1xMCB 16 A 1P-C	5 x 4 mm ² Pg 21	InA 32 A	5
200167 (ROS-I 1600 D/S)		-	-	-	-	-	2	-	-	-	-	-
200168 (ROS-I 1602 D)		-	-	1	1	2	-	-	1xMCB 16 A 3P-C 1xMCB 16 A 1P-C	5 x 4 mm ² Pg 21	InA 32 A	5
200169 (ROS-I 1602 D/S)		-	-	-	-	-	2	-	-	-	-	-
200170 (ROS-I 3200 D)		-	-	2	-	2	-	-	1xMCB 32 A 3P-C 1xMCB 16 A 1P-C	5 x 4 mm ² Pg 21	InA 32 A	5
200171 (ROS-I 3200 D/S)		-	-	-	-	-	2	-	-	-	-	-

InA = Rated current of switchgear and control gear assembly

DISTRIBUTION BOXES

4-modules distribution boxes Mini with handle

CONNECTING ENERGY



Mini distribution boxes ROS 4 IP44 without MCBs, economically pre-wired, handle

- Distribution boxes with handle have been designed to be part of mobile wiring.
- Distribution boxes do not require any maintenance after installation.
- Cover resistant against excessive heat and fire (650 °C glow wire test).
- Dimensions 305 x 190 x 106 mm (h x w x d).



200192

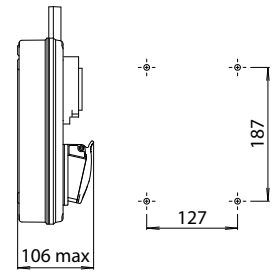
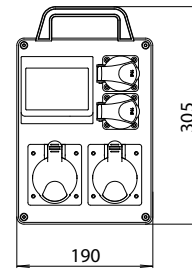

Complies with standards: STN EN 61439-1, STN EN 61439-3
 Mechanical resistance of box: IK10
 Degree of protection: IP44
 Material: ABS
 Nominal working voltage: 400 V~, 250 V~, 50/60 Hz
 Operating temperature: -25 °C to +55 °C

Ord. No. (Type)	Layout	CEE 400 V 5P		CEE 400 V 4P		250 V		Protection		Connection	InA	Pkg (pcs.)
		32 A	16 A	32 A	16 A	16 A Fr	16 A Sch	RCCB	MCBs			
200190 (ROS-I 1601 D/A)		-	2	-	-	2	-	-	-	5 x 4 mm ² Pg 21	InA 32 A	5
200191 (ROS-I 1601 D/A/S)		-	2	-	-	-	2	-	-	5 x 4 mm ² Pg 21	InA 32 A	5
200192 (ROS-I 1603 D/A)		1	1	-	-	2	-	-	-	5 x 4 mm ² Pg 21	InA 32 A	5
200193 (ROS-I 1603 D/A/S)		1	1	-	-	-	2	-	-	5 x 4 mm ² Pg 21	InA 32 A	5
200194 (ROS-I 3201 D/A)		2	-	-	-	2	-	-	-	5 x 4 mm ² Pg 21	InA 32 A	5
200195 (ROS-I 3201 D/A/S)		2	-	-	-	-	2	-	-	5 x 4 mm ² Pg 21	InA 32 A	5
200196 (ROS-I 1600 D/A)		-	-	-	2	2	-	-	-	5 x 4 mm ² Pg 21	InA 32 A	5
200197 (ROS-I 1600 D/A/S)		-	-	-	2	-	2	-	-	5 x 4 mm ² Pg 21	InA 32 A	5
200198 (ROS-I 1602 D/A)		-	-	1	1	2	-	-	-	5 x 4 mm ² Pg 21	InA 32 A	5
200199 (ROS-I 1602 D/A/S)		-	-	1	1	-	2	-	-	5 x 4 mm ² Pg 21	InA 32 A	5
200200 (ROS-I 3200 D/A)		-	-	2	-	2	-	-	-	5 x 4 mm ² Pg 21	InA 32 A	5
200201 (ROS-I 3200 D/A/S)		-	-	2	-	-	2	-	-	5 x 4 mm ² Pg 21	InA 32 A	5

InA = Rated current of switchgear and control gear assembly



DISTRIBUTION BOXES

0-modules distribution boxes Mini with handle

CONNECTING ENERGY



Mini distribution boxes ROS IP44 unprotected, handle

- Distribution boxes with handle have been designed to be part of mobile wiring.
- Distribution boxes do not require any maintenance after installation.
- Cover resistant against excessive heat and fire (650 °C glow wire test).
- Dimensions 305 x 190 x 106 mm (h x w x d).

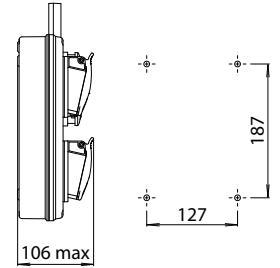
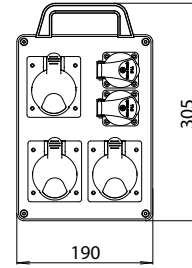

Complies with standards: STN EN 61439-1, STN EN 61439-3
 Mechanical resistance of box: IK10
 Degree of protection: IP44
 Material: ABS
 Nominal working voltage: 400 V~, 250 V~, 50/60 Hz
 Operating temperature: -25 °C to +55 °C

200224

Ord. No. (Type)	Layout	CEE 400 V 5P		CEE 400 V 4P		250 V		Protection		Connection	InA	Pkg (pcs.)
		32 A	16 A	32 A	16 A	16 A Fr	16 A Sch	RCCB	MCBs			
200220 (ROS 1601 D)		-	4	-	-	-	-	-	-	5 x 2,5 mm ² Pg 16	InA 16 A	5
200222 (ROS 1603 D)		-	3	-	-	2	-	-	-	5 x 2,5 mm ² Pg 21	InA 16 A	5
200223 (ROS 1603 D/S)		-	3	-	-	-	2	-	-	5 x 2,5 mm ² Pg 21	InA 16 A	5
200224 (ROS 1605 D)		-	2	-	-	4	-	-	-	5 x 2,5 mm ² Pg 21)	InA 16 A	5
200225 (ROS 1605 D/S)		-	2	-	-	-	4	-	-	5 x 2,5 mm ² Pg 21)	InA 16 A	5
200226 (ROS 1607 D)		2x CEE 230 V 16 A 3P				4	-	-	-	5 x 2,5 mm ² Pg 16	InA 16 A	5
200227 (ROS 1607 D/S)		2x CEE 230 V 16 A 3P				-	4	-	-	5 x 2,5 mm ² Pg 16	InA 16 A	5
200228 (ROS 3201 D)		4	-	-	-	-	-	-	-	5 x 4 mm ² Pg 21	InA 32 A	5
200230 (ROS 1600 D)		-	-	-	4	-	-	-	-	4 x 2,5 mm ² Pg 16	InA 16 A	5
200232 (ROS 1602 D)		-	-	-	3	2	-	-	-	5 x 2,5 mm ² Pg 21	InA 16 A	5
200233 (ROS 1602 D/S)		-	-	-	3	-	2	-	-	5 x 2,5 mm ² Pg 21	InA 16 A	5
200234 (ROS 1604 D)		-	-	-	2	4	-	-	-	5 x 2,5 mm ² Pg 21	InA 16 A	5
200235 (ROS 1604 D/S)		-	-	-	2	-	4	-	-	5 x 2,5 mm ² Pg 21	InA 16 A	5
200236 (ROS 3200 D)		-	-	4	-	-	-	-	-	4 x 4 mm ² Pg 21	InA 32 A	5

InA = Rated current of switchgear and control gear assembly



Micro distribution boxes ROSP IP54







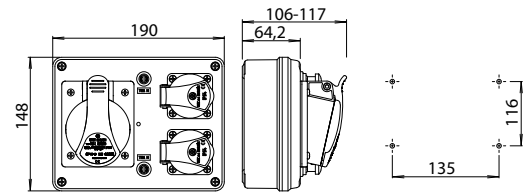









- Designed for wall mounting as part of a fixed wiring.
- Distribution boxes do not require any maintenance after installation.
- Cover resistant against excessive heat and fire (650 °C glow wire test).
- In case of combination of 16 A and 32 A sockets additional protection with F10 A / 250 V tube fuses.
- Dimensions 148 x 190 x 117 mm (h x w x d).



200272



Complies with standards:	STN EN 61439-1, STN EN 61439-3
Mechanical resistance of box:	IK10
Degree of protection:	IP54
Material:	ABS
Nominal working voltage:	400 V~, 250 V~, 50/60 Hz
Operating temperature:	-25 °C to +55 °C

Ord. No. (Type)	Layout	CEE 400 V 5P		CEE 400 V 4P		250 V		Protection Tube fuse	Connection	InA	Pkg (pcs.)
		32 A	16 A	32 A	16 A	16 A Fr	16 A Sch				
200260 (ROSP 4VZ)		-	-	-	-	4	-	-	3 x 2,5 mm ² Pg 16	InA 16	6
200261 (ROSP 4VZ/S)		-	-	-	-	-	4	-	3 x 2,5 mm ² Pg 16	InA 16 A	6
200262 (ROSP 6VZ)		-	-	-	-	6	-	-	3 x 2,5 mm ² Pg 16	InA 16 A	6
200263 (ROSP 6VZ/S)		-	-	-	-	-	6	-	3 x 2,5 mm ² Pg 16	InA 16 A	6
200264 (ROSP 1632)		-	1	-	-	1	-	-	5 x 2,5 mm ² Pg 16	InA 16 A	6
200265 (ROSP 1632/S)		-	1	-	-	-	1	-	5 x 2,5 mm ² Pg 16	InA 16 A	6
200266 (ROSP 3232)		1	-	-	-	1	-	1 x F10 A/250 V	5 x 4 mm ² Pg 21	InA 32 A	6
200267 (ROSP 3232/S)		1	-	-	-	-	1	1 x F10 A/250 V	5 x 4 mm ² Pg 21	InA 32 A	6
200268 (ROSP 1631)		-	1	-	-	2	-	-	5 x 2,5 mm ² Pg 16	InA 16 A	6
200269 (ROSP 1631/S)		-	1	-	-	-	2	-	5 x 2,5 mm ² Pg 16	InA 16 A	6
200270 (ROSP 3231)		1	-	-	-	2	-	2 x F10 A/250 V	5 x 4 mm ² Pg 21	InA 32 A	6
200271 (ROSP 3231/S)		1	-	-	-	-	2	2 x F10 A/250 V	5 x 4 mm ² Pg 21	InA 32 A	6
200272 (ROSP 1630)		-	-	-	1	2	-	-	5 x 2,5 mm ² Pg 16	InA 16 A	6
200273 (ROSP 1630/S)		-	-	-	1	-	2	-	5 x 2,5 mm ² Pg 16	InA 16 A	6
200274 (ROSP 3230)		-	-	1	-	2	-	2 x F10 A/250 V	5 x 4 mm ² Pg 21	InA 32 A	6
200275 (ROSP 3230/S)		-	-	1	-	-	2	2 x F10 A/250 V	5 x 4 mm ² Pg 21	InA 32 A	6

InA = Rated current of switchgear and control gear assembly







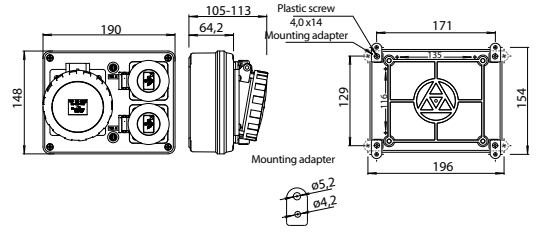



Micro distribution boxes ROSPG IP67

- Designed for wall mounting as part of a fixed wiring.
- Distribution boxes do not require any maintenance after installation.
- Cover resistant against excessive heat and fire (650 °C glow wire test).
- In case of combination of 16 A and 32 A sockets additional protection with F10 A / 250 V tube fuses.
- Mounting adapters and screws are included with boxes.
- Dimensions 148 x 190 x 113 mm (h x w x d).



200292

Complies with standards: STN EN 61439-1, STN EN 61439-3
 Mechanical resistance of box: IK10
 Degree of protection: IP67
 Material: ABS
 Nominal working voltage: 400 V~, 250 V~, 50/60 Hz
 Operating temperature: -25 °C to +55 °C

Ord. No. (Type)	Layout	CEE 400 V 5P		CEE 400 V 4P		250 V		Protection Tube fuse	Connection	InA	Pkg (pcs.)
		32 A	16 A	32 A	16 A	16 A Fr	16 A Sch				
200290 (ROSPG 1631)		-	1	-	-	2	-	-	5 x 2,5 mm ² Pg 16	InA 16 A	6
200291 (ROSPG 1631/S)		-	1	-	-	-	2	-	5 x 2,5 mm ² Pg 16	InA 16 A	6
200292 (ROSPG 3231)		1	-	-	-	2	-	2 x F10 A/250 V	5 x 4 mm ² Pg 21	InA 32 A	6
200293 (ROSPG 3231/S)		1	-	-	-	-	2	2 x F10 A/250 V	5 x 4 mm ² Pg 21	InA 32 A	6
200294 (ROSPG 1630)		-	-	-	1	2	-	-	5 x 2,5 mm ² Pg 16	InA 16 A	6
200295 (ROSPG 1630/S)		-	-	-	1	-	2	-	5 x 2,5 mm ² Pg 16	InA 16 A	6
200296 (ROSPG 3230)		-	-	1	-	2	-	2 x F10 A/250 V	5 x 4 mm ² Pg 21	InA 32 A	6
200297 (ROSPG 3230/S)		-	-	1	-	-	2	2 x F10 A/250 V	5 x 4 mm ² Pg 21	InA 32 A	6

InA = Rated current of switchgear and control gear assembly





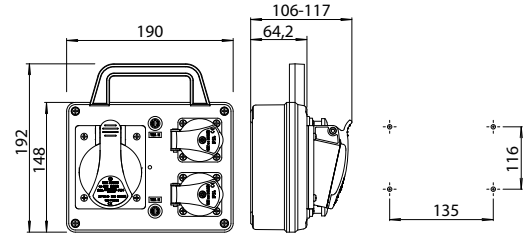











Micro distribution boxes ROSP IP54, handle

- Distribution boxes with handle have been designed to be part of mobile wiring.
- Distribution boxes do not require any maintenance after installation.
- Cover resistant against excessive heat and fire (650 °C glow wire test).
- In case of combination of 16 A and 32 A sockets additional protection with F10 A / 250 V tube fuses.
- Dimensions 192 x 190 x 117 mm (h x w x d).



200318

Complies with standards: STN EN 61439-1, STN EN 61439-3
 Mechanical resistance of box: IK10
 Degree of protection: IP54
 Material: ABS
 Nominal working voltage: 400 V~, 250 V~, 50/60 Hz
 Operating temperature: -25 °C to +55 °C

Ord. No. (Type)	Layout	CEE 400 V 5P		CEE 400 V 4P		250 V		Protection Tube fuse	Connection	InA	Pkg (pcs.)
		32 A	16 A	32 A	16 A	16 A Fr	16 A Sch				
200310 (ROSP 4VZ D)		-	-	-	-	4	-	-	3 x 2,5 mm ² Pg 16	InA 16 A	5
200311 (ROSP 4VZ D/S)		-	-	-	-	-	4	-	3 x 2,5 mm ² Pg 16	InA 16 A	5
200312 (ROSP 6VZ D)		-	-	-	-	6	-	-	3 x 2,5 mm ² Pg 16	InA 16 A	5
200313 (ROSP 6VZ D/S)		-	-	-	-	-	6	-	3 x 2,5 mm ² Pg 16	InA 16 A	5
200314 (ROSP 1632 D)		-	1	-	-	1	-	-	5 x 2,5 mm ² Pg 16	InA 16 A	5
200315 (ROSP 1632 D/S)		-	1	-	-	-	1	-	5 x 2,5 mm ² Pg 16	InA 16 A	5
200316 (ROSP 3232 D)		1	-	-	-	1	-	1 x F10 A/250 V	5 x 4 mm ² Pg 21	InA 32 A	5
200317 (ROSP 3232 D/S)		1	-	-	-	-	1	1 x F10 A/250 V	5 x 4 mm ² Pg 21	InA 32 A	5
200318 (ROSP 1631 D)		-	1	-	-	2	-	-	5 x 2,5 mm ² Pg 16	InA 16 A	5
200319 (ROSP 1631 D/S)		-	1	-	-	-	2	-	5 x 2,5 mm ² Pg 16	InA 16 A	5
200320 (ROSP 3231 D)		1	-	-	-	2	-	2 x F10 A/250 V	5 x 4 mm ² Pg 21	InA 32 A	5
200321 (ROSP 3231 D/S)		1	-	-	-	-	2	2 x F10 A/250 V	5 x 4 mm ² Pg 21	InA 32 A	5
200322 (ROSP 1630 D)		-	-	-	1	2	-	-	5 x 2,5 mm ² Pg 21	InA 16 A	5
200323 (ROSP 1630 D/S)		-	-	-	1	-	2	-	5 x 2,5 mm ² Pg 21	InA 16 A	5
200324 (ROSP 3230 D)		-	-	1	-	2	-	2 x F10 A/250 V	5 x 4 mm ² Pg 21	InA 32 A	5
200325 (ROSP 3230 D/S)		-	-	1	-	-	2	2 x F10 A/250 V	5 x 4 mm ² Pg 21	InA 32 A	5

InA = Rated current of switchgear and control gear assembly



DISTRIBUTION BOXES

Distribution boxes Micro with handle

Micro distribution boxes ROSPG IP67, handle

- Distribution boxes with handle have been designed to be part of mobile wiring.
- Distribution boxes do not require any maintenance after installation.
- Cover resistant against excessive heat and fire (650 °C glow wire test).
- In case of combination of 16 A and 32 A sockets additional protection with F10 A / 250 V tube fuses.
- Mounting adapters and screws are included with boxes.
- Dimensions 192 x 190 x 113 mm (h x w x d).



200340

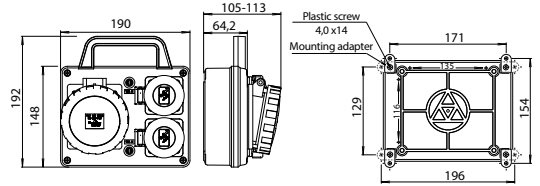

Complies with standards: STN EN 61439-1, STN EN 61439-3
 Mechanical resistance of box: IK10
 Degree of protection: IP67
 Material: ABS
 Nominal working voltage: 400 V~, 250 V~, 50/60 Hz
 Operating temperature: -25 °C to +55 °C

Ord. No. (Type)	Layout	CEE 400 V 5P		CEE 400 V 4P		250 V		Protection Tube fuse	Connection	InA	Pkg (pcs.)
		32 A	16 A	32 A	16 A	16 A Fr	16 A Sch				
200340 (ROSPG 1631 D)		-	1	-	-	2	-	-	5 x 2,5 mm ² Pg 16	InA 16 A	5
200341 (ROSPG 1631 D/S)		-	-	-	-	-	2	-	-	-	-
200342 (ROSPG 3231 D)		1	-	-	-	2	-	2 x F10 A/250 V	5 x 4 mm ² Pg 21	InA 32 A	5
200343 (ROSPG 3231 D/S)		-	-	-	-	-	2	-	-	-	-
200344 (ROSPG 1630 D)		-	-	-	1	2	-	-	5 x 2,5 mm ² Pg 16	InA 16 A	5
200345 (ROSPG 1630 D/S)		-	-	-	-	-	2	-	-	-	-
200346 (ROSPG 3230 D)		-	-	1	-	2	-	2 x F10 A/250 V	5 x 4 mm ² Pg 21	InA 32 A	5
200347 (ROSPG 3230 D/S)		-	-	-	-	-	2	-	-	-	-

InA = Rated current of switchgear and control gear assembly





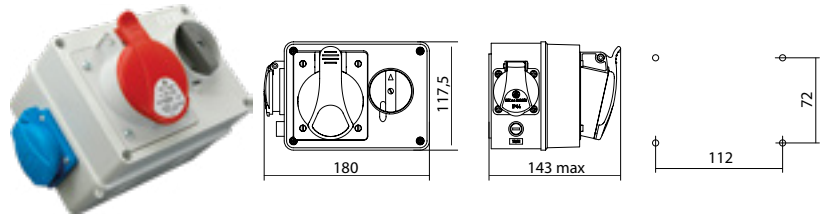

Micro boxes VZS IP44 with switch

- Distribution boxes are designed as part of a fixed wiring.
- Distribution boxes do not require any maintenance after installation.
- Cover resistant against excessive heat and fire (650 °C glow wire test).
- In case of combination of 16 A and 32 A sockets additional protection with F10 A / 250 V tube fuses.
- Suitable for connecting of 3-phase and 1-phase electrical appliances with the possibility to switch off distribution box by a switch.
- Possibility of locking in position 0 or I.
- Dimensions 117,5 x 180 x 143 mm (h x w x d).

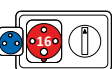

200360

Complies with standards: STN EN 60309-1, -2
 Mechanical resistance of box: IK10
 Degree of protection: IP44
 Material: ABS
 Nominal working voltage: 400 V~, 250 V~, 50/60 Hz
 Operating temperature: -25 °C to +55 °C

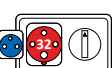
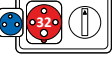
Ord. No. (Type)	Layout	CEE 400 V 5P		CEE 400 V 4P		250 V		Protection Tube fuse	Equipment Switch 01	Connection	InA	Pkg (pcs.)
		32 A	16 A	32 A	16 A	16 A Fr	16 A Sch					
200360 (VZS 165)		-	1	-	-	1	-	-	1	5 x 6 mm ² Pg 16	InA 16 A	4
200361 (VZS 165/S)		-	-	-	-	-	1	-	-	-	-	-
200362 (VZS 325)		1	-	-	-	1	-	1 x F10 A/250 V	1	5 x 6 mm ² Pg 21	InA 32 A	4
200363 (VZS 325/S)		-	-	-	-	-	1	-	-	-	-	-
200364 (VZS 164)		-	-	-	1	1	-	-	1	5 x 6 mm ² Pg 16	InA 16 A	4
200365 (VZS 164/S)		-	-	-	-	-	1	-	-	-	-	-
200366 (VZS 324)		-	-	1	-	1	-	1 x F10 A/250 V	1	5 x 6 mm ² Pg 21	InA 32 A	4
200367 (VZS 324/S)		-	-	-	-	-	1	-	-	-	-	-

InA = Rated current of switchgear and control gear assembly

Inlets VPS IP44 with switch

- Cover resistant against excessive heat and fire (650 °C glow wire test).
- Powered by straight inlet.
- Possibility of locking in position 0 or I.
- Dimensions 158 x 118 x 154 mm (h x w x d) Ord. No. 200380.
- Dimensions 158 x 118 x 165 mm (h x w x d) Ord. No. 200382.

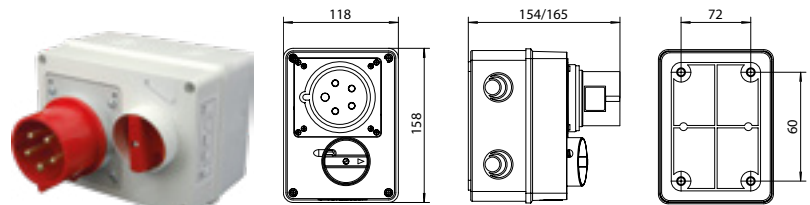

200380

Complies with standards: STN EN 60309-1, -2
 Mechanical resistance of box: IK10
 Degree of protection: IP44
 Material: ABS
 Nominal working voltage: 400 V~, 250 V~, 50/60 Hz
 Operating temperature: -25 °C to +55 °C

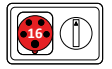
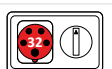
Ord. No. (Type)	Layout	CEE 400 V 5P		CEE 400 V 4P		250 V		Protection Tube fuse	Equipment Switch 01	Connection	InA	Pkg (pcs.)
		32 A	16 A	32 A	16 A	16 A Fr	16 A Sch					
200380 (VPS 1653)		-	-	-	-	-	-	-	1	CEE inlet 16 A/5P/400 V	InA 16 A	8
200382 (VPS 3253)		-	-	-	-	-	-	-	1	CEE inlet 32 A/5P/400 V	InA 32 A	8

InA = Rated current of switchgear and control gear assembly



DISTRIBUTION BOXES

Compact distribution boxes with inlet

CONNECTING ENERGY



Compact distribution boxes ROP IP44 with straight inlet

- Cover resistant against excessive heat and fire (650 °C glow wire test).
- Powered by straight inlet 16 A or 32 A.
- Using in exterior or interior, residential sector, building sites and industrial zones.

Complies with standards: STN EN 61439-1, STN EN 61439-3
 Mechanical resistance: IK06
 Degree of protection: IP44
 Material: ABS
 Nominal working voltage: 400 V~, 250 V~, 50/60 Hz
 Operating temperature: -25 °C to +55 °C

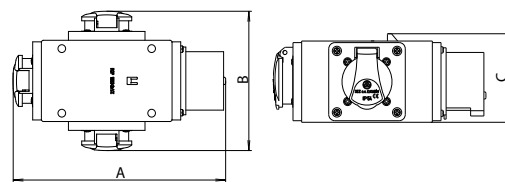

200408

Ord. No. (Type)	Layout	CEE 400 V 5P		CEE 400 V 4P		250 V		Connection	InA	Pkg (pcs.)	Dimensions		
		32 A	16 A	32 A	16 A	16 A Fr	16 A Sch				A	B	C
200400 (ROP 1653-VZ)		-	2	-	-	1	-	CEE inlet 16 A/5P/400 V	InA 16 A	5	202	205	94
200401 (ROP 1653-VZ/S)		-	-	-	-	-	1						
200402 (ROP 1653-2xVZ)		-	1	-	-	2	-	CEE inlet 16 A/5P/400 V	InA 16 A	4	240	130	94
200403 (ROP 1653-2xVZ/S)		-	-	-	-	-	2						
200404 (ROP 1653-3xVZ)		-	-	-	-	3	-	CEE inlet 16 A/5P/400 V	InA 16 A	4	202	130	86
200405 (ROP 1653-3xVZ/S)		-	-	-	-	-	3						
200406 (ROP 1653)		-	3	-	-	-	-	CEE inlet 16 A/5P/400 V	InA 16 A	5	240	205	94
200408 (ROP 3253)		3	-	-	-	-	-	CEE inlet 32 A/5P/400 V	InA 32 A	4	261	229	105
200410 (ROP 1643)		-	-	-	3	-	-	CEE inlet 16 A/4P/400 V	InA 16 A	5	238	201	90
200412 (ROP 3243)		-	-	3	-	-	-	CEE inlet 32 A/4P/400 V	InA 32 A	4	257	221	98

InA = Rated current of switchgear and control gear assembly



DISTRIBUTION BOXES

Compact distribution boxes with inlet

CONNECTING ENERGY



Compact distribution boxes ROP IP44 with supply cable

- Compact distribution boxes with supply cable and plug, other product features identical to **Compact distribution boxes ROP IP44 with straight inlet**.
- Supply cable 2 m terminated with a plug.

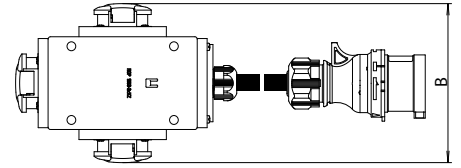

Complies with standards:	STN EN 61439-1, STN EN 61439-3
Mechanical resistance:	IK06
Degree of protection:	IP44
Material:	ABS
Nominal working voltage:	400 V~, 250 V~, 50/60 Hz
Operating temperature:	-25 °C to +55 °C

200424

Ord. No. (Type)	Layout	CEE 400 V 5P		CEE 400 V 4P		250 V		Connection	InA	Pkg (pcs.)	Dimensions		
		32 A	16 A	32 A	16 A	16 A Fr	16 A Sch				A	B	C
200416 (ROP 1653-VZ/IVN)		-	2	-	-	1	-	cable 2 m with plug 16 A/5P/400 V	InA 16 A	1	-	205	-
200417 (ROP 1653-VZ/S/IVN)		-	-	-	-	-	1						
200418 (ROP 1653-2xVZ/IVN)		-	1	-	-	2	-	cable 2 m with plug 16 A/5P/400 V	InA 16 A	1	-	130	-
200419 (ROP 1653-2xVZ/S/IVN)		-	-	-	-	-	2						
200420 (ROP 1653-3xVZ/IVN)		-	-	-	-	3	-	cable 2 m with plug 16 A/5P/400 V	InA 16 A	1	-	130	-
200421 (ROP 1653-3xVZ/S/IVN)		-	-	-	-	-	3						
200422 (ROP 1653/IVN)		-	3	-	-	-	-	cable 2 m with plug 16 A/5P/400 V	InA 16 A	1	-	205	-
200424 (ROP 3253/IVN)		3	-	-	-	-	-						
200426 (ROP 1643/IVN)		-	-	-	3	-	-	cable 2 m with plug 16 A/4P/400 V	InA 16 A	1	-	201	-
200428 (ROP 3243/IVN)		-	-	3	-	-	-						

InA = Rated current of switchgear and control gear assembly



Mini distribution boxes ROK IP54

- Cover resistant against excessive heat and fire (650 °C glow wire test).
- Powered by straight inlet or installed cable gland M 25.
- Using in exterior or interior, residential sector, building sites and industrial zones.
- Order no. 200440, 200441 contain a quick connector with a hose insert for compressed air distribution.

Complies with standards: STN EN 61439-1, STN EN 61439-3
 Mechanical resistance: IK07
 Degree of protection: IP54
 Material: ABS
 Nominal working voltage: 400 V~, 250 V~, 50/60 Hz
 Operating temperature: -25 °C to +55 °C



200434

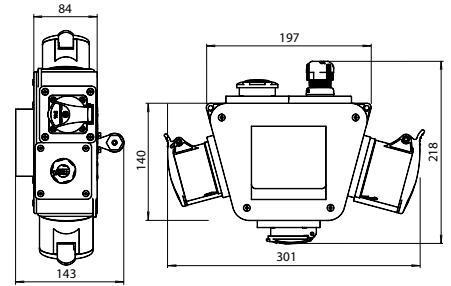

Ord. No. (Type)	Layout	CEE 400 V 5P		CEE 400 V 4P		250 V		Protection		Connection	InA	Pkg (pcs.)	
		32 A	16 A	32 A	16 A	16 A Fr	16 A Sch	RCCB	MCBs				
200430 (ROK/FI-51)		1	1	-	-	2	-	1xRCCB 40 A/4/0,03 A (Type A)	-	5 x 4 mm ² M 25	InA 16 A	1	
200431 (ROK/FI-51/S)		-	-	-	-	-	2	-	-	-	-	-	
200432 (ROK/FI-55)		-	-	-	-	4	-	-	1xRCCB 40 A/4/0,03 A (Type A)	-	5 x 4 mm ² M 25	InA 16 A	2
200433 (ROK/FI-55/S)		-	-	-	-	-	4	-	-	-	-	-	-
200434 (ROK/I-38)		2	1	-	-	1	-	-	-	1xMCB 16 A 3P-C 1xMCB 16 A 1P-B	CEE inlet 32 A/5P/400 V	InA 32 A	2
200435 (ROK/I-38/S)		-	-	-	-	-	1	-	-	-	-	-	-
200436 (ROK/x-05)		-	-	-	-	4	-	-	-	-	CEE inlet 16 A/5P/400 V	InA 16 A	2
200437 (ROK/x-05/S)		-	-	-	-	-	4	-	-	-	-	-	-
200438 (ROK/x-70)		-	-	-	2	2	-	-	-	-	5 x 4 mm ² M 25	InA 16 A	2
200439 (ROK/x-70/S)		-	-	-	-	-	2	-	-	-	-	-	-
200440 (ROK/x-55 V)		-	-	-	-	4	-	-	-	-	5 x 4 mm ² M 25	InA 16 A	1
200441 (ROK/x-55 V/S)	-	-	-	-	-	4	-	-	-	-	-	-	

InA = Rated current of switchgear and control gear assembly



Distribution boxes ROS 4 IP44 protected

- Designed for wall mounting as part of a fixed wiring.
- Distribution boxes do not require any maintenance after installation.
- Cover resistant against excessive heat and fire (650 °C glow wire test).
- Dimensions 240 x 160 x 160 mm (h x w x d).



200802

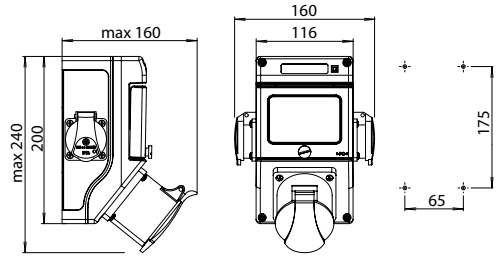

Complies with standards: STN EN 61439-1, STN EN 61439-3
 Mechanical resistance of box: IK08
 Degree of protection: IP44
 Material: ABS
 Nominal working voltage: 400 V~, 250 V~, 50/60 Hz
 Operating temperature: -25 °C to +55 °C

Ord. No. (Type)	Layout	CEE 400 V 5P		CEE 400 V 4P		250 V		Protection		Connection	InA	Pkg (pcs.)
		32 A	16 A	32 A	16 A	16 A Fr	16 A Sch	RCCB	MCBs			
200800 (ROS 4/I-12)		-	1	-	-	2	-	-	1xMCB 16 A 3P-C 1xMCB 16 A 1P-B	5 x 4 mm ² M 25	InA 16 A	8
200801 (ROS 4/I-12/S)		-	1	-	-	-	2	-	-	-	-	-
200802 (ROS 4/I-10)		1	-	-	-	2	-	-	1xMCB 32 A 3P-C 1xMCB 16 A 1P-B	5 x 6 mm ² M 32	InA 32 A	8
200803 (ROS 4/I-10/S)		-	-	-	-	-	2	-	-	-	-	-
200804 (ROS 4/I-52)		-	-	-	1	2	-	-	1xMCB 16 A 3P-C 1xMCB 16 A 1P-B	5 x 4 mm ² M 25	InA 16 A	8
200805 (ROS 4/I-52/S)		-	-	-	1	-	2	-	-	-	-	-
200806 (ROS 4/I-50)		-	-	1	-	2	-	-	1xMCB 32 A 3P-C 1xMCB 16 A 1P-B	5 x 6 mm ² M 32	InA 32 A	8
200807 (ROS 4/I-50/S)		-	-	1	-	-	2	-	-	-	-	-

InA = Rated current of switchgear and control gear assembly

Distribution boxes ROS 4 IP44 without MCBs, fully pre-wired

- Designed for wall mounting as part of a fixed wiring.
- Distribution boxes do not require any maintenance after installation.
- Cover resistant against excessive heat and fire (650 °C glow wire test).
- Dimensions 240 x 160 x 160 mm (h x w x d).



200822

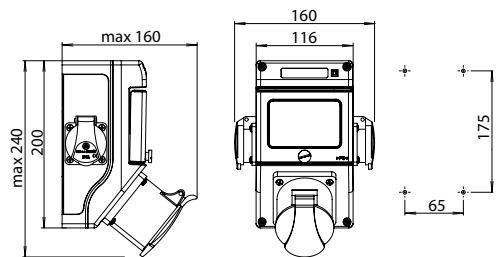

Complies with standards: STN EN 61439-1, STN EN 61439-3
 Mechanical resistance of box: IK08
 Degree of protection: IP44
 Material: ABS
 Nominal working voltage: 400 V~, 250 V~, 50/60 Hz
 Operating temperature: -25 °C to +55 °C

Ord. No. (Type)	Layout	CEE 400 V 5P		CEE 400 V 4P		250 V		Protection		Connection	InA	Pkg (pcs.)
		32 A	16 A	32 A	16 A	16 A Fr	16 A Sch	RCCB	MCBs			
200820 (ROS 4/x-12)		-	1	-	-	2	-	-	-	5 x 4 mm ² M 25	InA 16 A	10
200821 (ROS 4/x-12/S)		-	1	-	-	-	2	-	-	-	-	-
200822 (ROS 4/x-10)		1	-	-	-	2	-	-	-	5 x 6 mm ² M 32	InA 32 A	10
200823 (ROS 4/x-10/S)		-	-	-	-	-	2	-	-	-	-	-
200824 (ROS 4/x-52)		-	-	-	1	2	-	-	-	5 x 4 mm ² M 25	InA 16 A	10
200825 (ROS 4/x-52/S)		-	-	-	1	-	2	-	-	-	-	-
200826 (ROS 4/x-50)		-	-	1	-	2	-	-	-	5 x 6 mm ² M 32	InA 32 A	10
200827 (ROS 4/x-50/S)		-	-	1	-	-	2	-	-	-	-	-

InA = Rated current of switchgear and control gear assembly



Distribution boxes ROS 4/V IP44 with reversing switch





- Designed for wall mounting as part of a fixed wiring.
- Distribution boxes do not require any maintenance after installation.
- In case of combination of 16 A and 32 A sockets additional protection with F10 A / 250 V tube fuses.
- Possibility of locking in position 0.
- Cover resistant against excessive heat and fire (650 °C glow wire test).
- Dimensions 212 x 144 x 160 mm (h x w x d).

Complies with standards: STN EN 61439-1, STN EN 61439-3
 Mechanical resistance of box: IK08
 Degree of protection: IP44
 Material: ABS
 Nominal working voltage: 400 V~, 250 V~, 50/60 Hz
 Operating temperature: -25 °C to +55 °C

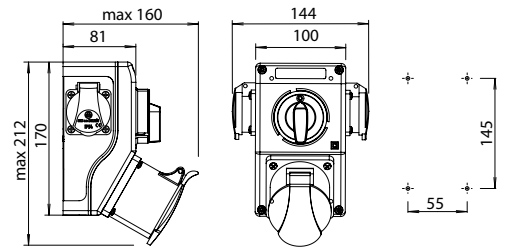

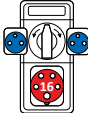
200840

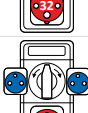
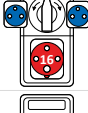
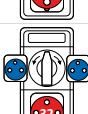

Ord. No. (Type)	Layout	CEE 400 V 5P		CEE 400 V 4P		250 V		Protection Tube fuse	Equipment Reversing switch	Connection	InA	Pkg (pcs.)
		32 A	16 A	32 A	16 A	16 A Fr	16 A Sch					
200840 (ROS 4/V-12 LP)		-	1	-	-	2	-	-	1	5 x 4 mm ² M 25	InA 16 A	2
200841 (ROS 4/V-12 LP/S)		-	-	-	-	-	2	-	-	-	-	-
200842 (ROS 4/V-10 LP)		1	-	-	-	2	-	2 x F10 A/250 V	1	5 x 6 mm ² M 32	InA 32 A	2
200843 (ROS 4/V-10 LP/S)		-	-	-	-	-	2	-	-	-	-	-
200844 (ROS 4/V-52 LP)		-	-	-	1	2	-	-	1	5 x 4 mm ² M 25	InA 16 A	2
200845 (ROS 4/V-52 LP/S)		-	-	-	-	-	2	-	-	-	-	-
200846 (ROS 4/V-50 LP)		-	-	1	-	2	-	2 x F10 A/250 V	1	5 x 6 mm ² M 32	InA 32 A	2
200847 (ROS 4/V-50 LP/S)		-	-	-	-	-	2	-	-	-	-	-

InA = Rated current of switchgear and control gear assembly

Distribution boxes ROS 4/V IP44 with switch





- Designed for wall mounting as part of a fixed wiring.
- Distribution boxes do not require any maintenance after installation.
- In case of combination of 16 A and 32 A sockets additional protection with F10 A / 250 V tube fuses.
- Cover resistant against excessive heat and fire (650 °C glow wire test).
- Possibility of locking in position 0.
- Dimensions 212 x 144 x 160 mm (h x w x d).

Complies with standards: STN EN 61439-1, STN EN 61439-3
 Mechanical resistance of box: IK08
 Degree of protection: IP44
 Material: ABS
 Nominal working voltage: 400 V~, 250 V~, 50/60 Hz
 Operating temperature: -25 °C to +55 °C

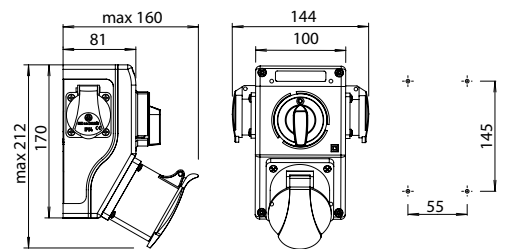

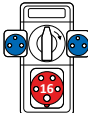
200860

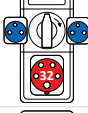
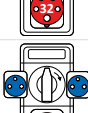
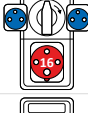
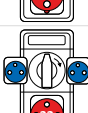

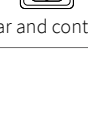
Ord. No. (Type)	Layout	CEE 400 V 5P		CEE 400 V 4P		250 V		Protection Tube fuse	Equipment Switch 01	Connection	InA RDF	Pkg (pcs.)
		32 A	16 A	32 A	16 A	16 A Fr	16 A Sch					
200860 (ROS 4/V-12)		-	1	-	-	2	-	-	1	5 x 4 mm ² M 25	InA 16 A	2
200861 (ROS 4/V-12/S)		-	-	-	-	-	2	-	-	-	-	-
200862 (ROS 4/V-10)		1	-	-	-	2	-	2 x F10 A/250 V	1	5 x 6 mm ² M 32	InA 32 A	2
200863 (ROS 4/V-10/S)		-	-	-	-	-	2	-	-	-	-	-
200864 (ROS 4/V-52)		-	-	-	1	2	-	-	1	5 x 4 mm ² M 25	InA 16 A	2
200865 (ROS 4/V-52/S)		-	-	-	-	-	2	-	-	-	-	-
200866 (ROS 4/V-50)		-	-	1	-	2	-	2 x F10 A/250 V	1	5 x 6 mm ² M 32	InA 32 A	2
200867 (ROS 4/V-50/S)		-	-	-	-	-	2	-	-	-	-	-

InA = Rated current of switchgear and control gear assembly



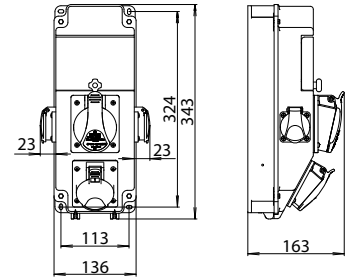

Distribution boxes ROS 6 IP54 protected

- Designed for wall mounting as part of a fixed wiring.
- Distribution boxes do not require any maintenance after installation.
- Cover resistant against excessive heat and fire (650 °C glow wire test).
- Pre-injected centric circle for glands from bottom: 1x (M25; M32).
- Dimensions 343 x 136 x 163 mm (h x w x d).

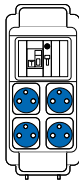
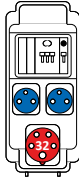
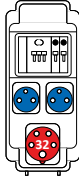
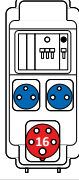
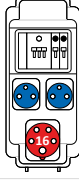

Complies with standards: STN EN 61439-1, STN EN 61439-3
 Mechanical resistance of box: IK10
 Degree of protection: IP54
 Material: ABS
 Nominal working voltage: 400 V~, 250 V~, 50/60 Hz
 Operating temperature: -25 °C to +55 °C









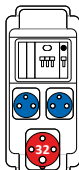
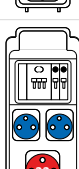

201014

Ord. No. (Type)	Layout	CEE 400 V 5P		CEE 400 V 4P		250 V		Protection		Connection	InA	Pkg (pcs.)
		32 A	16 A	32 A	16 A	16 A Fr	16 A Sch	RCCB	MCBs			
201000 (ROS 5-6/FI-01)		-	-	-	-	4	-	1xRCCB 25 A/2/0,03 A (Type A)	1xMCB 16 A 1P-B	3 x 2,5 mm ² M 25	InA 16 A	1
201001 (ROS 5-6/FI-01/S)		-	-	-	-	-	4					
201002 (ROS 5-6/I-10)		1	-	-	-	2	-	-	1xMCB 32 A 3P-C 1xMCB 16 A 1P-B	5 x 6 mm ² M 32	InA 32 A	1
201003 (ROS 5-6/I-10/S)		-	-	-	-	-	2					
201004 (ROS 5-6/I-11)		1	-	-	-	2	-	-	1xMCB 32 A 3P-C 2xMCB 16 A 1P-B	5 x 6 mm ² M 32	InA 32 A	1
201005 (ROS 5-6/I-11/S)		-	-	-	-	-	2					
201006 (ROS 5-6/I-12)		-	1	-	-	2	-	-	1xMCB 16 A 3P-C 1xMCB 16 A 1P-B	5 x 6 mm ² M 32	InA 32 A	1
201007 (ROS 5-6/I-12/S)		-	-	-	-	-	2					
201008 (ROS 5-6/I-13)		-	1	-	-	2	-	-	1xMCB 16 A 3P-C 2xMCB 16 A 1P-B	5 x 6 mm ² M 32	InA 32 A	1
201009 (ROS 5-6/I-13/S)		-	-	-	-	-	2					
201010 (ROS 5-6/I-14)		1	1	-	-	1	-	-	1xMCB 16 A 3P-C 1xMCB 16 A 1P-B	5 x 6 mm ² M 32	InA 32 A	1
201011 (ROS 5-6/I-14/S)		-	-	-	-	-	1					
201012 (ROS 5-6/I-15)		1	1	-	-	2	-	-	1xMCB 16 A 3P-C 1xMCB 16 A 1P-B	5 x 6 mm ² M 32	InA 32 A	1
201013 (ROS 5-6/I-15/S)		-	-	-	-	-	2					
201014 (ROS 5-6/I-16)		1	1	-	-	2	-	-	1xMCB 16 A 3P-C 2xMCB 16 A 1P-B	5 x 6 mm ² M 32	InA 32 A	1
201015 (ROS 5-6/I-16/S)		-	-	-	-	-	2					

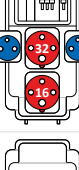
InA = Rated current of switchgear and control gear assembly



Distribution boxes ROS 6 IP54 protected (continued)

Ord. No. (Type)	Layout	CEE 400 V 5P		CEE 400 V 4P		250 V		Protection		Connection	InA	Pkg (pcs.)
		32 A	16 A	32 A	16 A	16 A Fr	16 A Sch	RCCB	MCBs			
201016 (ROS 5-6/I-50)		-	-	1	-	2		-	1xMCB 32 A 3P-C 1xMCB 16 A 1P-B	5 x 6 mm ² M 32	InA 32 A	1
201017 (ROS 5-6/I-50/S)		-	-	1	-		2	-				
201018 (ROS 5-6/I-51)		-	-	1	-	2		-	1xMCB 32 A 3P-C 2xMCB 16 A 1P-B	5 x 6 mm ² M 32	InA 32 A	1
201019 (ROS 5-6/I-51/S)		-	-	1	-		2	-				
201020 (ROS 5-6/I-52)		-	-	-	1	2		-	1xMCB 16 A 3P-C 1xMCB 16 A 1P-B	5 x 6 mm ² M 32	InA 32 A	1
201021 (ROS 5-6/I-52/S)		-	-	-	1		2	-				
201022 (ROS 5-6/I-53)		-	-	-	1	2		-	1xMCB 16 A 3P-C 2xMCB 16 A 1P-B	5 x 6 mm ² M 32	InA 32 A	1
201023 (ROS 5-6/I-53/S)		-	-	-	1		2	-				
201024 (ROS 5-6/I-54)		-	-	1	1	1		-	1xMCB 16 A 3P-C 1xMCB 16 A 1P-B	5 x 6 mm ² M 32	InA 32 A	1
201025 (ROS 5-6/I-54/S)		-	-	1	1		1	-				
201026 (ROS 5-6/I-55)		-	-	1	1	2		-	1xMCB 16 A 3P-C 1xMCB 16 A 1P-B	5 x 6 mm ² M 32	InA 32 A	1
201027 (ROS 5-6/I-55/S)		-	-	1	1		2	-				
201028 (ROS 5-6/I-56)		-	-	1	1	2		-	1xMCB 16 A 3P-C	5 x 6 mm ²	InA	1
201029 (ROS 5-6/I-56/S)		-	-	1	1		2	-	2xMCB 16 A 1P-B	M 32	32 A	1

InA = Rated current of switchgear and control gear assembly



Distribution boxes ROS 6 IP54 without MCBs, fully pre-wired

- Designed for wall mounting as part of a fixed wiring.
- Distribution boxes do not require any maintenance after installation.
- Cover resistant against excessive heat and fire (650 °C glow wire test).
- Pre-injected centric circle for glands from bottom: 1x (M25; M32).
- Dimensions 343 x 136 x 163 mm (h x w x d).



201040

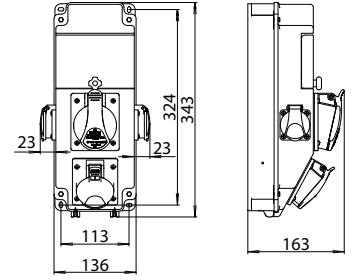



Complies with standards: STN EN 61439-1, STN EN 61439-3
 Mechanical resistance of box: IK10
 Degree of protection: IP54
 Material: ABS
 Nominal working voltage: 400 V~, 250 V~, 50/60 Hz
 Operating temperature: -25 °C to +55 °C

Ord. No. (Type)	Layout	CEE 400 V 5P		CEE 400 V 4P		250 V		Protection		Connection	InA	Pkg (pcs.)
		32 A	16 A	32 A	16 A	16 A Fr	16 A Sch	RCCB	MCBs			
201040 (ROS 5-6/x-01)		1	1	-	-	-	-	-	-	5 x 6 mm ² M 32	InA 16 A	8
201042 (ROS 5-6/x-10)		1	-	-	-	2	-	-	-	5 x 6 mm ² M 32	InA 32 A	8
201043 (ROS 5-6/x-10/S)		-	-	-	-	-	2	-	-	-	-	1
201044 (ROS 5-6/x-12)		-	1	-	-	2	-	-	-	5 x 6 mm ² M 32	InA 32 A	8
201045 (ROS 5-6/x-12/S)		-	-	-	-	-	2	-	-	-	-	1
201046 (ROS 5-6/x-14)		1	1	-	-	1	-	-	-	5 x 6 mm ² M 32	InA 32 A	6
201047 (ROS 5-6/x-14/S)		-	-	-	-	-	1	-	-	-	-	1
201048 (ROS 5-6/x-15)		1	1	-	-	2	-	-	-	5 x 6 mm ² M 32	InA 32 A	6
201049 (ROS 5-6/x-15/S)		-	-	-	-	-	2	-	-	-	-	1
201050 (ROS 5-6/x-16)		-	-	-	-	4	-	-	-	5 x 6 mm ² M 32	InA 32 A	8
201051 (ROS 5-6/x-16/S)		-	-	-	-	-	4	-	-	-	-	1
201052 (ROS 5-6/x-17)		-	2	-	-	2	-	-	-	5 x 6 mm ² M 32	InA 32 A	6
201053 (ROS 5-6/x-17/S)		-	-	-	-	-	2	-	-	-	-	1
201054 (ROS 5-6/x-18)		2	-	-	-	2	-	-	-	5 x 6 mm ² M 32	InA 32 A	6
201055 (ROS 5-6/x-18/S)		-	-	-	-	-	2	-	-	-	-	1

InA = Rated current of switchgear and control gear assembly

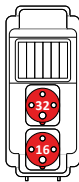
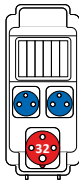
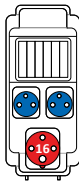

Distribution boxes ROS 6 IP54 without MCBs, fully pre-wired (continued)

Ord. No. (Type)	Layout	CEE 400 V 5P		CEE 400 V 4P		250 V		Protection		Connection	InA	Pkg (pcs.)
		32 A	16 A	32 A	16 A	16 A Fr	16 A Sch	RCCB	MCBs			
201056 (ROS 5-6/x-41)		-	-	1	1	-	-	-	-	5 x 6 mm ² M 32	InA 16 A	8
201058 (ROS 5-6/x-50)		-	-	1	-	2	-	-	-	5 x 6 mm ² M 32	InA 32 A	8
201059 (ROS 5-6/x-50/S)		-	-	-	-	2	-	-	-	-	-	-
201060 (ROS 5-6/x-52)		-	-	-	1	2	-	-	-	5 x 6 mm ² M 32	InA 32 A	8
201061 (ROS 5-6/x-52/S)		-	-	-	-	2	-	-	-	-	-	1
201062 (ROS 5-6/x-54)		-	-	1	1	1	-	-	-	5 x 6 mm ² M 32	InA 16 A	6
201063 (ROS 5-6/x-54/S)		-	-	-	-	1	-	-	-	-	-	1
201064 (ROS 5-6/x-55)		-	-	1	1	2	-	-	-	5 x 6 mm ² M 32	InA 32 A	6
201065 (ROS 5-6/x-55/S)		-	-	-	-	2	-	-	-	-	-	1

InA = Rated current of switchgear and control gear assembly



Distribution boxes ROS M6 IP54 protected





- Designed for wall mounting as part of a fixed wiring.
- Distribution boxes do not require any maintenance after installation.
- Cover resistant against excessive heat and fire (650 °C glow wire test).
- Doubled insulation.
- Pre-injected circle ø 20 mm for cable glands - bottom and top.
- Dimensions 495 x 125 x 107 mm (h x w x d).

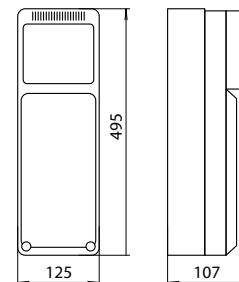

201090

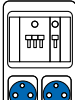

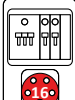
Complies with standards: STN EN 61439-1, STN EN 61439-3
 Mechanical resistance of box: IK09
 Degree of protection: IP54, IP65 Ord. No. 201090
 Material: ABS
 Nominal working voltage: 400 V~, 250 V~, 50/60 Hz
 Operating temperature: -25 °C to +55 °C

Ord. No. (Type)	Layout	CEE 400 V 5P		CEE 400 V 4P		250 V		Protection		Connection	InA	Pkg (pcs.)
		32 A	16 A	32 A	16 A	16 A Fr	16 A Sch	RCCB	MCBs			
201080 (ROS M6/I-02)						2	-	-	1xMCB 16 A 3P-C 1xMCB 16 A 1P-C	5 x 6 mm ² M 32	InA 32 A	2
201081 (ROS M6/I-02/S)		1	1	-	-	-	2	-				
201082 (ROS M6/I-03)						4	-	-	1xMCB 16 A 3P-C 2xMCB 16 A 1P-C	5 x 6 mm ² M 32	InA 32 A	2
201083 (ROS M6/I-03/S)		-	1	-	-	-	4	-				

InA = Rated current of switchgear and control gear assembly

Distribution boxes ROS M6 IP65 protected

- Distribution boxes protected with IP65 protection, other product features identical to **Distribution boxes ROS M6 IP54 protected**.

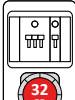
Ord. No. (Type)	Layout	CEE 400 V 5P		CEE 400 V 4P		CEE 230 V 3P	Protection		Connection	InA	Pkg (pcs.)
		32 A	16 A	32 A	16 A	16 A	RCCB	MCBs			
201090 (ROS M6/I-01))						1	-	1xMCB 16 A 3P-C 1xMCB 16 A 1P-C	5 x 6 mm ² M 32	InA 32 A	2

InA = Rated current of switchgear and control gear assembly



Distribution boxes ROS M6 IP54 without MCBs, economically pre-wired





- Designed for wall mounting as part of a fixed wiring.
- Distribution boxes do not require any maintenance after installation.
- Cover resistant against excessive heat and fire (650 °C glow wire test).
- Doubled insulation.
- Pre-injected circle ø 20 mm for cable glands - bottom and top.
- Dimensions 495 x 125 x 107 mm (h x w x d).

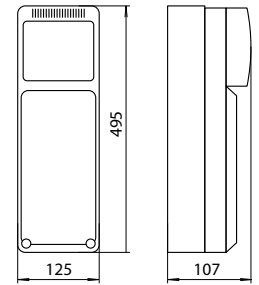

201102

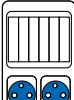

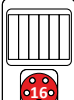
Complies with standards: STN EN 61439-1, STN EN 61439-3
 Mechanical resistance of box: IK09
 Degree of protection: IP54, IP65 Ord. No. 201110
 Material: ABS
 Nominal working voltage: 400 V~, 250 V~, 50/60 Hz
 Operating temperature: -25 °C to +55 °C

Ord. No. (Type)	Layout	CEE 400 V 5P		CEE 400 V 4P		250 V		Protection		Connection	InA	Pkg (pcs.)
		32 A	16 A	32 A	16 A	16 A Fr	16 A Sch	RCCB	MCBs			
201100 (ROS M6/x-02)						2	-			5 x 6 mm ² M 32	InA 16 A	2
201101 (ROS M6/x-02/S)		1	1	-	-	-	2	-	-			
201102 (ROS M6/x-03)						4	-			5 x 6 mm ² M 32	InA 16 A	2
201103 (ROS M6/x-03/S)		-	1	-	-	-	4	-	-			

InA = Rated current of switchgear and control gear assembly

Distribution boxes ROS M6 IP65 without MCBs, economically pre-wired

- Distribution boxes without MCBs with IP65 protection, other product features identical to **Distribution boxes ROS M6 IP54 without MCBs, economically pre-wired.**

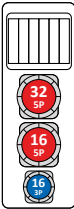
Ord. No. (Type)	Layout	CEE 400 V 5P		CEE 400 V 4P		CEE 230 V 3P	Protection		Connection	InA	Pkg (pcs.)
		32 A	16 A	32 A	16 A	16 A	RCCB	MCBs			
201110 (ROS M6/x-01))		1	1	-	-	1			5 x 6 mm ² M 32	InA 16 A	2
							-	-			

InA = Rated current of switchgear and control gear assembly





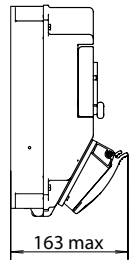
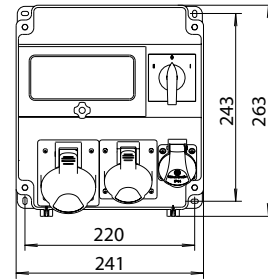



Distribution boxes ROS 7 IP54 protected with reversing switch

- Designed for wall mounting as part of a fixed wiring.
- Distribution boxes do not require any maintenance after installation.
- Cover resistant against excessive heat and fire (650 °C glow wire test).
- Possibility of locking in position 0.
- Pre-injected centric circles for glands on top: 2x (M25; M32); bottom and rear: 1x (M25; M32).
- Dimensions 263 x 241 x 163 mm (h x w x d).

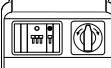

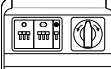
201502

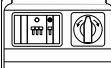
Complies with standards: STN EN 61439-1, STN EN 61439-3
 Mechanical resistance of box: IK10
 Degree of protection: IP54
 Material: ABS
 Nominal working voltage: 400 V~, 250 V~, 50/60 Hz
 Operating temperature: -25 °C to +55 °C

Ord. No. (Type)	Layout	CEE 400 V 5P		CEE 400 V 4P		250 V		Equipment	Protection	Connection	InA	Pkg (pcs.)
		32 A	16 A	32 A	16 A	16 A Fr	16 A Sch					
201500 (ROS 7/I-02)		1	1	-	-	1	-	1	1xMCB 16 A 3P-C 1xMCB 32 A 3P-C 1xMCB 16 A 1P-B	5 x 6 mm ² M 32	InA 32 A	1
201501 (ROS 7/I-02/S)						-	1					
201502 (ROS 7/I-04)		1	1	-	-	1	-	1	1xMCB 16 A 3P-C 1xMCB 16 A 1P-B	5 x 6 mm ² M 32	InA 32 A	1
201503 (ROS 7/I-04/S)						-	1					
201504 (ROS 7/I-42)		-	-	1	1	1	-	1	1xMCB 16 A 3P-C 1xMCB 32 A 3P-C 1xMCB 16 A 1P-B	5 x 6 mm ² M 32	InA 32 A	1
201505 (ROS 7/I-42/S)						-	1					
201506 (ROS 7/I-44)		-	-	1	1	1	-	1	1xMCB 16 A 3P-C 1xMCB 16 A 1P-B	5 x 6 mm ² M 32	InA 32 A	1
201507 (ROS 7/I-44/S)						-	1					

InA = Rated current of switchgear and control gear assembly

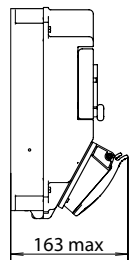
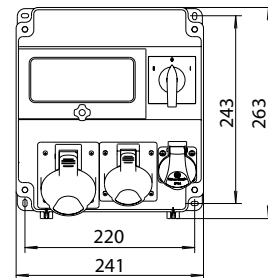

Distribution boxes ROS 7 IP54 without MCBs, economically pre-wired with reversing switch

- Designed for wall mounting as part of a fixed wiring.
- Distribution boxes do not require any maintenance after installation.
- Cover resistant against excessive heat and fire (650 °C glow wire test).
- Possibility of locking in position 0.
- Max. cable entry: 5 x 4 mm² for 16 A a 5 x 6 mm² for 32 A.
- Pre-injected centric circles for glands on top: 2x (M25; M32); bottom and rear: 1x (M25; M32).
- Dimensions 263 x 241 x 163 mm (h x w x d).

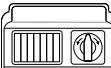

201520

Complies with standards: STN EN 61439-1, STN EN 61439-3
 Mechanical resistance of box: IK10
 Degree of protection: IP54
 Material: ABS
 Nominal working voltage: 400 V~, 250 V~, 50/60 Hz
 Operating temperature: -25 °C to +55 °C

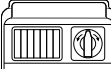
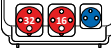
Ord. No. (Type)	Layout	CEE 400 V 5P		CEE 400 V 4P		250 V		Equipment	Protection	Connection	InA	Pkg (pcs.)
		32 A	16 A	32 A	16 A	16 A Fr	16 A Sch					
201520 (ROS 7/x-02)		1	1	-	-	1	-	1	-	5 x 6 mm ² M 32	InA 16 A	1
201521 (ROS 7/x-02/S)						-	1					
201522 (ROS 7/x-42)		-	-	1	1	1	-	1	-	5 x 6 mm ² M 32	InA 16 A	1
201533 (ROS 7/x-42/S)						-	1					

InA = Rated current of switchgear and control gear assembly



Distribution boxes ROS 7 IP54 protected with switch





- Designed for wall mounting as part of a fixed wiring.
- Distribution boxes do not require any maintenance after installation.
- Cover resistant against excessive heat and fire (650 °C glow wire test).
- Possibility of locking in position 0.
- Pre-injected centric circles for glands on top: 2x (M25; M32); bottom and rear: 1x (M25; M32).
- Dimensions 263 x 241 x 163 mm (h x w x d).

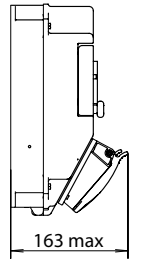
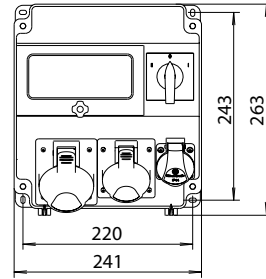

201542

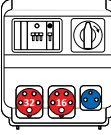
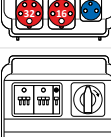
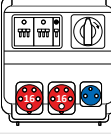
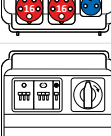
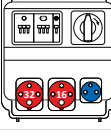
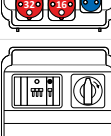

Complies with standards: STN EN 61439-1, STN EN 61439-3
 Mechanical resistance of box: IK10
 Degree of protection: IP54
 Material: ABS
 Nominal working voltage: 400 V~, 250 V~, 50/60 Hz
 Operating temperature: -25 °C to +55 °C

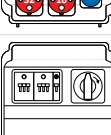
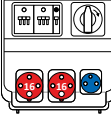
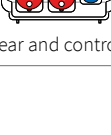
Ord. No. (Type)	Layout	CEE 400 V 5P		CEE 400 V 4P		250 V		Equipment Switch 01	Protection MCBs	Connection	InA	Pkg (pcs.)
		32 A	16 A	32 A	16 A	16 A Fr	16 A Sch					
201540 (ROS 7/I-01)		1	1	-	-	1	-	1	1xMCB 16 A 3P-C 1xMCB 32 A 3P-C 1xMCB 16 A 1P-B	5 x 6 mm ² M 32	InA 32 A	1
201541 (ROS 7/I-01/S)						-	1					
201542 (ROS 7/I-03)		1	1	-	-	1	-	1	1xMCB 16 A 3P-C 1xMCB 16 A 1P-B	5 x 6 mm ² M 32	InA 32 A	1
201543 (ROS 7/I-03/S)						-	1					
201544 (ROS 7/I-11)		-	2	-	-	1	-	1	2xMCB 16 A 3P-C 1xMCB 16 A 1P-B	5 x 6 mm ² M 32	InA 32 A	1
201545 (ROS 7/I-11/S)						-	1					
201546 (ROS 7/I-41)		-	-	1	1	1	-	1	1xMCB 16 A 3P-C 1xMCB 32 A 3P-C 1xMCB 16 A 1P-B	5 x 6 mm ² M 32	InA 32 A	1
201547 (ROS 7/I-41/S)						-	1					
201548 (ROS 7/I-43)		-	-	1	1	1	-	1	1xMCB 16 A 3P-C 1xMCB 16 A 1P-B	5 x 6 mm ² M 32	InA 32 A	1
201549 (ROS 7/I-43/S)						-	1					
201550 (ROS 7/I-51)		-	-	-	2	1	-	1	2xMCB 16 A 3P-C 1xMCB 16 A 1P-B	5 x 6 mm ² M 32	InA 32 A	1
201551 (ROS 7/I-51/S)						-	1					

InA = Rated current of switchgear and control gear assembly



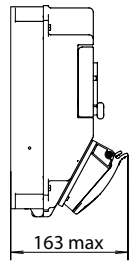
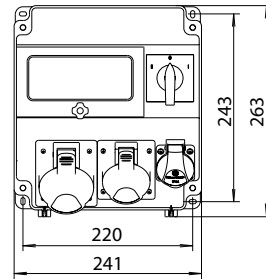

Distribution boxes ROS 7 IP54 without MCBs, economically pre-wired with switch

- Designed for wall mounting as part of a fixed wiring.
- Distribution boxes do not require any maintenance after installation.
- Cover resistant against excessive heat and fire (650 °C glow wire test).
- Possibility of locking in position 0.
- Pre-injected centric circles for glands on top: 2x (M25; M32); bottom and rear: 1x (M25; M32).
- Dimensions 263 x 241 x 163 mm (h x w x d).

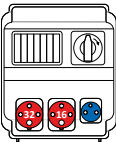

Complies with standards: STN EN 61439-1, STN EN 61439-3
 Mechanical resistance of box: IK10
 Degree of protection: IP54
 Material: ABS
 Nominal working voltage: 400 V~, 250 V~, 50/60 Hz
 Operating temperature: -25 °C to +55 °C

201570

Ord. No. (Type)	Layout	CEE 400 V 5P		CEE 400 V 4P		250 V		Equipment Switch 01	Protection MCBs	Connection	InA	Pkg (pcs.)
		32 A	16 A	32 A	16 A	16 A Fr	16 A Sch					
201570 (ROS 7/x-01)		1	1	-	-	1	-	1	-	5 x 6 mm ² M 32	InA 16 A	1
201571 (ROS 7/x-01/S)						-	1					
201572 (ROS 7/x-41)		-	-	1	1	1	-	1	-	5 x 6 mm ² M 32	InA 16 A	1
201573 (ROS 7/x-41/S)						-	1					

InA = Rated current of switchgear and control gear assembly



Distribution boxes ROS 11 IP54 with RCCB





- Designed for wall mounting as part of a fixed wiring.
- Distribution boxes do not require any maintenance after installation.
- Cover resistant against excessive heat and fire (650 °C glow wire test).
- Pre-injected centric circles for glands on top: 2x (M25; M32); bottom and rear: 1x (M25; M32).
- Dimensions 343 x 241 x 163 mm (h x w x d).

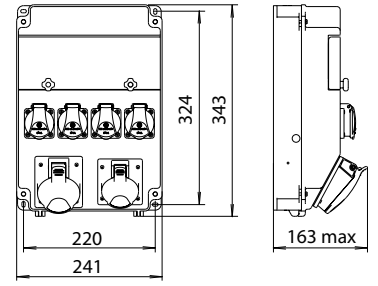

202034

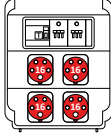

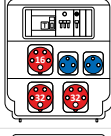
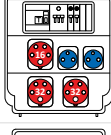
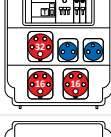
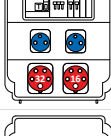
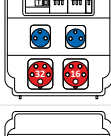
Complies with standards: STN EN 61439-1, STN EN 61439-3
 Mechanical resistance of box: IK10
 Degree of protection: IP54
 Material: ABS
 Nominal working voltage: 400 V~, 250 V~, 50/60 Hz
 Operating temperature: -25 °C to +55 °C

Ord. No. (Type)	Layout	CEE 400 V 5P		CEE 400 V 4P		250 V		Protection		Connection	InA	Pkg (pcs.)
		32 A	16 A	32 A	16 A	16 A Fr	16 A Sch	RCCB	MCBs			
202000 (ROS 11/FI-01)		4	-	-	-	-	-	1xRCCB 40 A/4/0,03 A (Type A)	2xMCB 32 A 3P-C	5 x 6 mm ² M 32	InA 40 A	1
202002 (ROS 11/FI-03)		-	4	-	-	-	-	1xRCCB 40 A/4/0,03 A (Type A)	2xMCB 16 A 3P-C	5 x 6 mm ² M 32	InA 32 A	1
202004 (ROS 11/FI-05))		2	2	-	-	-	-	1xRCCB 40 A/4/0,03 A (Type A)	1xMCB 16 A 3P-C	5 x 6 mm ² M 32	InA 32 A	1
202006 (ROS 11/FI-11)		2	1	-	-	2	-	1xRCCB 40 A/4/0,03 A (Type A)	1xMCB 16 A 3P-C 1xMCB 16 A 1P-B	5 x 6 mm ² M 32	InA 32 A	1
202007 (ROS 11/FI-11/S)		2	1	-	-	-	2	1xRCCB 40 A/4/0,03 A (Type A)	1xMCB 16 A 3P-C 2xMCB 16 A 1P-B	5 x 6 mm ² M 32	InA 32 A	1
202008 (ROS 11/FI-12)		2	1	-	-	2	-	1xRCCB 40 A/4/0,03 A (Type A)	1xMCB 16 A 3P-C 2xMCB 16 A 1P-B	5 x 6 mm ² M 32	InA 32 A	1
202009 (ROS 11/FI-12/S)		2	1	-	-	-	2	1xRCCB 40 A/4/0,03 A (Type A)	1xMCB 16 A 3P-C 2xMCB 16 A 1P-B	5 x 6 mm ² M 32	InA 32 A	1
202010 (ROS 11/FI-14)		1	2	-	-	2	-	1xRCCB 40 A/4/0,03 A (Type A)	1xMCB 16 A 3P-C 1xMCB 16 A 1P-B	5 x 6 mm ² M 32	InA 32 A	1
202011 (ROS 11/FI-14/S)		1	2	-	-	-	2	1xRCCB 40 A/4/0,03 A (Type A)	1xMCB 16 A 3P-C 2xMCB 16 A 1P-B	5 x 6 mm ² M 32	InA 32 A	1
202012 (ROS 11/FI-15)		1	2	-	-	2	-	1xRCCB 40 A/4/0,03 A (Type A)	1xMCB 16 A 3P-C 2xMCB 16 A 1P-B	5 x 6 mm ² M 32	InA 32 A	1
202013 (ROS 11/FI-15/S)		1	2	-	-	-	2	1xRCCB 40 A/4/0,03 A (Type A)	1xMCB 16 A 3P-C 2xMCB 16 A 1P-B	5 x 6 mm ² M 32	InA 32 A	1
202014 (ROS 11/FI-65)		1	1	-	-	2	-	1xRCCB 40 A/4/0,03 A (Type A)	1xMCB 16 A 3P-C 2xMCB 16 A 1P-B	5 x 6 mm ² M 32	InA 32 A	1
202015 (ROS 11/FI-65/S)		1	1	-	-	-	2	1xRCCB 40 A/4/0,03 A (Type A)	1xMCB 16 A 3P-C 2xMCB 16 A 1P-B	5 x 6 mm ² M 32	InA 32 A	1
202016 (ROS 11/FI-632)		1	1	-	-	2	-	1xRCCB 40 A/4/0,03 A (Type A)	1xMCB 16 A 3P-C 1xMCB 32 A 3P-C 1xMCB 16 A 1P-B	5 x 6 mm ² M 32	InA 40 A	1
202017 (ROS 11/FI-632/S)		1	1	-	-	-	2	1xRCCB 40 A/4/0,03 A (Type A)	1xMCB 16 A 3P-C 1xMCB 32 A 3P-C 1xMCB 16 A 1P-B	5 x 6 mm ² M 32	InA 40 A	1
202018 (ROS 11/FI-66)		2	-	-	-	2	-	1xRCCB 40 A/4/0,03 A (Type A)	1xMCB 32 A 3P-C 2xMCB 16 A 1P-B	5 x 6 mm ² M 32	InA 40 A	1
202019 (ROS 11/FI-66/S)		2	-	-	-	-	2	1xRCCB 40 A/4/0,03 A (Type A)	1xMCB 32 A 3P-C 2xMCB 16 A 1P-B	5 x 6 mm ² M 32	InA 40 A	1

InA = Rated current of switchgear and control gear assembly

Distribution boxes ROS 11 IP54 with RCCB (continued)

Ord. No. (Type)	Layout	CEE 400 V 5P		CEE 400 V 4P		250 V		Protection		Connection	InA	Pkg (pcs.)
		32 A	16 A	32 A	16 A	16 A Fr	16 A Sch	RCCB	MCBs			
202020 (ROS 11/FI-64)		-	2	-	-	2	-	1xRCCB 40 A/4/0,03 A (Type A)	1xMCB 16 A 3P-C 2xMCB 16 A 1P-B	5 x 6 mm ² M 32	InA 32 A	1
202021 (ROS 11/FI-64/S)		-	-	-	-	-	2	-	-	-	-	-
202022 (ROS 11/FI-26)		1	1	-	-	2	-	1xRCCB 40 A/4/0,03 A (Type A)	1xMCB 16 A 3P-C 1xMCB 32 A 3P-C 1xMCB 16 A 1P-B	5 x 6 mm ² M 32	InA 40 A	1
202023 (ROS 11/FI-26/S)		-	-	-	-	-	2	-	-	-	-	-
202024 (ROS 11/FI-31)		1	1	1	1	2	-	1xRCCB 40 A/4/0,03 A (Type A)	1xMCB 16 A 3P-C 2xMCB 16 A 1P-B	5 x 6 mm ² M 32	InA 32 A	1
202025 (ROS 11/FI-31/S)		-	-	-	-	-	2	-	-	-	-	-
202026 (ROS 11/FI-67)		1	1	-	-	3	-	1xRCCB 40 A/4/0,03 A (Type A)	1xMCB 16 A 3P-C 3xMCB 16 A 1P-B	5 x 6 mm ² M 32	InA 32 A	1
202027 (ROS 11/FI-67/S)		-	-	-	-	-	3	-	-	-	-	-
202028 (ROS 11/FI-69)		2	-	-	-	3	-	1xRCCB 40 A/4/0,03 A (Type A)	1xMCB 32 A 3P-C 3xMCB 16 A 1P-B	5 x 6 mm ² M 32	InA 40 A	1
202029 (ROS 11/FI-69/S)		-	-	-	-	-	3	-	-	-	-	-
202030 (ROS 11/FI-68)		-	2	-	-	3	-	1xRCCB 40 A/4/0,03 A (Type A)	1xMCB 16 A 3P-C 3xMCB 16 A 1P-B	5 x 6 mm ² M 32	InA 32 A	1
202031 (ROS 11/FI-68/S)		-	-	-	-	-	3	-	-	-	-	-
202032 (ROS 11/FI-70)		-	1	-	-	3	-	1xRCCB 40 A/4/0,03 A (Type A)	1xMCB 16 A 3P-C 3xMCB 16 A 1P-B	5 x 6 mm ² M 32	InA 32 A	1
202033 (ROS 11/FI-70/S)		-	-	-	-	-	3	-	-	-	-	-
202034 (ROS 11/FI-21)		1	1	-	-	4	-	1xRCCB 40 A/4/0,03 A (Type A)	1xMCB 16 A 3P-C 2xMCB 16 A 1P-B	5 x 6 mm ² M 32	InA 32 A	1
202035 (ROS 11/FI-21/S)		-	-	-	-	-	4	-	-	-	-	-
202036 (ROS 11/FI-22)		2	-	-	-	4	-	1xRCCB 40 A/4/0,03 A (Type A)	1xMCB 32 A 3P-C 2xMCB 16 A 1P-B	5 x 6 mm ² M 32	InA 40 A	1
202037 (ROS 11/FI-22/S)		-	-	-	-	-	4	-	-	-	-	-
202038 (ROS 11/FI-23)		-	2	-	-	4	-	1xRCCB 40 A/4/0,03 A (Type A)	1xMCB 16 A 3P-C 2xMCB 16 A 1P-B	5 x 6 mm ² M 32	InA 16 A	1
202039 (ROS 11/FI-23/S)		-	-	-	-	-	4	-	-	-	-	-
202040 (ROS 11/FI-24)		1	-	-	-	6	-	1xRCCB 40 A/4/0,03 A (Type A)	6xMCB 16 A 1P-B	5 x 6 mm ² M 32	InA 32 A	1
202041 (ROS 11/FI-24/S)		-	-	-	-	-	6	-	-	-	-	-
202042 (ROS 11/FI-25)		-	-	-	-	7	-	1xRCCB 40 A/4/0,03 A (Type A)	3xMCB 16 A 1P-B	5 x 6 mm ² M 32	InA 32 A	1
202043 (ROS 11/FI-25/S)		-	-	-	-	-	7	-	-	-	-	-

InA = Rated current of switchgear and control gear assembly



Distribution boxes ROS 11 IP54 protected

- Designed for wall mounting as part of a fixed wiring.
- Distribution boxes do not require any maintenance after installation.
- Cover resistant against excessive heat and fire (650 °C glow wire test).
- Ord. No. 202088, 202089 with safety toroidal transformer (SELV) 24 V AC / 150 VA.
- Pre-injected centric circles for glands on top: 2x (M25; M32); bottom and rear: 1x (M25; M32).
- Dimensions 343 x 241 x 163 mm (h x w x d).

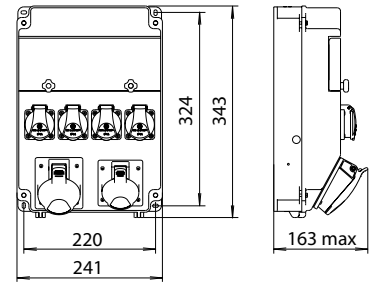



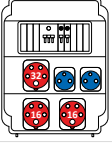

Complies with standards: STN EN 61439-1, STN EN 61439-3
 Mechanical resistance of box: IK10
 Degree of protection: IP54
 Material: ABS
 Nominal working voltage: 400 V~, 250 V~, 50/60 Hz
 Operating temperature: -25 °C to +55 °C

202084

Ord. No. (Type)	Layout	CEE 400 V 5P		CEE 400 V 4P		250 V		Protection		Connection	InA	Pkg (pcs.)	
		32 A	16 A	32 A	16 A	16 A Fr	16 A Sch	RCCB	MCBs				
202060 (ROS 11/I-01)		4	-	-	-	-	-	-	-	2xMCB 32 A 3P-C	5 x 6 mm ² M 32	InA 40 A	1
202062 (ROS 11/I-11)		2	1	-	-	2	-	-	-	1xMCB 16 A 3P-C 1xMCB 16 A 1P-B	5 x 6 mm ² M 32	InA 32 A	1
202063 (ROS 11/I-11/S)						-	2	-	-				
202064 (ROS 11/I-12)		2	1	-	-	2	-	-	-	1xMCB 16 A 3P-C 2xMCB 16 A 1P-B	5 x 6 mm ² M 32	InA 32 A	1
202065 (ROS 11/I-12/S)						-	2	-	-				
202066 (ROS 11/I-13)		2	1	-	-	2	-	-	-	1xMCB 16 A 3P-C 1xMCB 32 A 3P-C 2xMCB 16 A 1P-B	5 x 6 mm ² M 32	InA 40 A	1
202067 (ROS 11/I-13/S)						-	2	-	-				
202068 (ROS 11/I-14)		1	2	-	-	2	-	-	-	1xMCB 16 A 3P-C 1xMCB 16 A 1P-B	5 x 6 mm ² M 32	InA 32 A	1
202069 (ROS 11/I-14/S)						-	2	-	-				
202070 (ROS 11/I-15)		1	2	-	-	2	-	-	-	1xMCB 16 A 3P-C 2xMCB 16 A 1P-B	5 x 6 mm ² M 32	InA 32 A	1
202071 (ROS 11/I-15/S)						-	2	-	-				
202072 (ROS 11/I-16)		1	2	-	-	2	-	-	-	2xMCB 16 A 3P-C 2xMCB 16 A 1P-B	5 x 6 mm ² M 32	InA 32 A	1
202073 (ROS 11/I-16/S)						-	2	-	-				
202074 (ROS 11/I-17)		1	2	-	-	2	-	-	-	2xMCB 16 A 3P-C 1xMCB 32 A 3P-C 2xMCB 16 A 1P-B	5 x 6 mm ² M 32	InA 40 A	1
202075 (ROS 11/I-17/S)						-	2	-	-				
202076 (ROS 11/I-21)		1	1	-	-	4	-	-	-	1xMCB 16 A 3P-C 2xMCB 16 A 1P-B	5 x 6 mm ² M 32	InA 32 A	1
202077 (ROS 11/I-21/S)						-	4	-	-				
202078 (ROS 11/I-22)		1	1	-	-	4	-	-	-	1xMCB 16 A 3P-C 1xMCB 32 A 3P-C 2xMCB 16 A 1P-B	5 x 6 mm ² M 32	InA 40 A	1
202079 (ROS 11/I-22/S)						-	4	-	-				

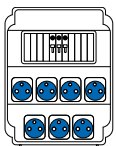
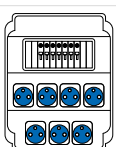
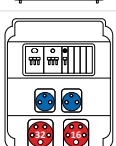
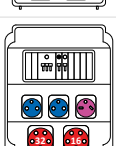
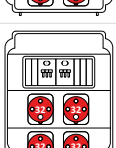
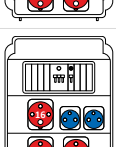
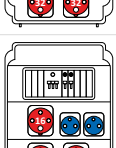
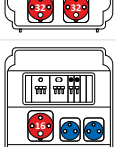
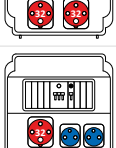
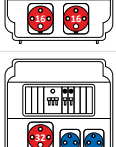
InA = Rated current of switchgear and control gear assembly



Distribution boxes ROS 11 IP54 protected (continued)

Ord. No. (Type)	Layout	CEE 400 V 5P		CEE 400 V 4P		250 V		Protection		Connection	InA	Pkg (pcs.)
		32 A	16 A	32 A	16 A	16 A Fr	16 A Sch	RCCB	MCBs			
202080 (ROS 11/I-23)		1	1	-	-	4	-	-	1xMCB 16 A 3P-C 1xMCB 32 A 3P-C 4xMCB 16 A 1P-B	5 x 6 mm ² M 32	InA 40 A	1
202081 (ROS 11/I-23/S)		-	-	-	-	-	4	-	-	-	-	-
202082 (ROS 11/I-25)		-	-	-	-	7	-	-	3xMCB 16 A 1P-B	5 x 6 mm ² M 32	InA 32 A	1
202083 (ROS 11/I-25/S)		-	-	-	-	-	7	-	-	-	-	-
202084 (ROS 11/I-26)		-	-	-	-	7	-	-	7xMCB 16 A 1P-B	5 x 6 mm ² M 32	InA 32 A	1
202085 (ROS 11/I-26/S)		-	-	-	-	-	7	-	-	-	-	-
202086 (ROS 11/I-632)		1	1	-	-	2	-	-	1xMCB 16 A 3P-C 1xMCB 32 A 3P-C 1xMCB 16 A 1P-B	5 x 6 mm ² M 32	InA 40 A	1
202087 (ROS 11/I-632/S)		-	-	-	-	-	2	-	-	-	-	-
202088 (ROS 11/I-32/24 V)		1	1	-	-	2	-	-	1xMCB 16 A 3P-C 1xMCB 6 A 1P-C 1xMCB 16 A 1P-B	5 x 6 mm ² M 32	InA 32 A	1
202089 (ROS 11/I-32/24 V/S)		-	-	-	-	1 x 24 V/10 A	2	-	-	-	-	-
202090 (ROS 11/I-41)		-	-	4	-	-	-	-	2xMCB 32 A 3P-C	5 x 6 mm ² M 32	InA 40 A	1
202092 (ROS 11/I-51)		-	-	2	1	2	-	-	1xMCB 16 A 3P-C 1xMCB 16 A 1P-B	5 x 6 mm ² M 32	InA 32 A	1
202093 (ROS 11/I-51/S)		-	-	-	-	-	2	-	-	-	-	-
202094 (ROS 11/I-52)		-	-	2	1	2	-	-	1xMCB 16 A 3P-C 2xMCB 16 A 1P-B	5 x 6 mm ² M 32	InA 32 A	1
202095 (ROS 11/I-52/S)		-	-	-	-	-	2	-	-	-	-	-
202096 (ROS 11/I-53)		-	-	2	1	2	-	-	1xMCB 16 A 3P-C 1xMCB 32 A 3P-C 2xMCB 16 A 1P-B	5 x 6 mm ² M 32	InA 40 A	1
202097 (ROS 11/I-53/S)		-	-	-	-	-	2	-	-	-	-	-
202098 (ROS 11/I-54)		-	-	1	2	2	-	-	1xMCB 16 A 3P-C 1xMCB 16 A 1P-B	5 x 6 mm ² M 32	InA 32 A	1
202099 (ROS 11/I-54/S)		-	-	-	-	-	2	-	-	-	-	-
202100 (ROS 11/I-55)		-	-	1	2	2	-	-	1xMCB 16 A 3P-C 2xMCB 16 A 1P-B	5 x 6 mm ² M 32	InA 32 A	1
202101 (ROS 11/I-55/S)		-	-	-	-	-	2	-	-	-	-	-

InA = Rated current of switchgear and control gear assembly

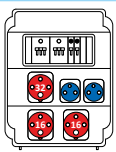
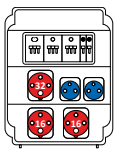
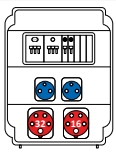
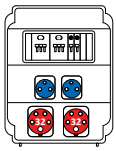
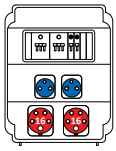
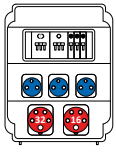
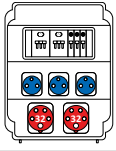
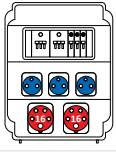
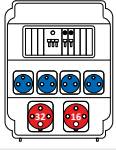
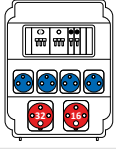
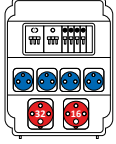

Distribution boxes ROS 11 IP54 protected (continued)

Ord. No. (Type)	Layout	CEE 400 V 5P		CEE 400 V 4P		250 V		Protection		Connection	InA	Pkg (pcs.)
		32 A	16 A	32 A	16 A	16 A Fr	16 A Sch	RCCB	MCBs			
202102 (ROS 11/I-56)		-	-	1	2	2	-	-	2xMCB 16 A 3P-C 2xMCB 16 A 1P-B	5 x 6 mm ² M 32	InA 32 A	1
202103 (ROS 11/I-56/S)		-	-	1	2	-	2	-	2xMCB 16 A 3P-C 1xMCB 32 A 3P-C 2xMCB 16 A 1P-B	5 x 6 mm ² M 32	InA 40 A	1
202104 (ROS 11/I-57)		-	-	1	2	2	-	-	1xMCB 32 A 3P-C 1xMCB 16 A 3P-C 2xMCB 16 A 1P-B	5 x 6 mm ² M 32	InA 40 A	1
202105 (ROS 11/I-57/S)		-	-	1	2	-	2	-	1xMCB 32 A 3P-C 1xMCB 16 A 3P-C 2xMCB 16 A 1P-B	5 x 6 mm ² M 32	InA 40 A	1
202106 (ROS 11/I-65)		1	1	-	-	2	-	-	1xMCB 32 A 3P-C 1xMCB 16 A 3P-C 2xMCB 16 A 1P-B	5 x 6 mm ² M 32	InA 40 A	1
202107 (ROS 11/I-65/S)		1	1	-	-	-	2	-	2xMCB 32 A 3P-C 2xMCB 16 A 1P-B	5 x 6 mm ² M 32	InA 40 A	1
202108 (ROS 11/I-66)		2	-	-	-	2	-	-	2xMCB 32 A 3P-C 2xMCB 16 A 1P-B	5 x 6 mm ² M 32	InA 40 A	1
202109 (ROS 11/I-66/S)		2	-	-	-	-	2	-	2xMCB 16 A 3P-C 2xMCB 16 A 1P-B	5 x 6 mm ² M 32	InA 32 A	1
202110 (ROS 11/I-64)		-	2	-	-	2	-	-	1xMCB 16 A 3P-C 1xMCB 32 A 3P-C 3xMCB 16 A 1P-B	5 x 6 mm ² M 32	InA 40 A	1
202111 (ROS 11/I-64/S)		-	2	-	-	-	2	-	2xMCB 16 A 3P-C 3xMCB 16 A 1P-B	5 x 6 mm ² M 32	InA 40 A	1
202112 (ROS 11/I-67)		1	1	-	-	3	-	-	1xMCB 16 A 3P-C 1xMCB 32 A 3P-C 3xMCB 16 A 1P-B	5 x 6 mm ² M 32	InA 40 A	1
202113 (ROS 11/I-67/S)		1	1	-	-	-	3	-	2xMCB 32 A 3P-C 3xMCB 16 A 1P-B	5 x 6 mm ² M 32	InA 40 A	1
202114 (ROS 11/I-69)		2	-	-	-	3	-	-	2xMCB 16 A 3P-C 3xMCB 16 A 1P-B	5 x 6 mm ² M 32	InA 40 A	1
202115 (ROS 11/I-69/S)		2	-	-	-	-	3	-	2xMCB 16 A 3P-C 3xMCB 16 A 1P-B	5 x 6 mm ² M 32	InA 32 A	1
202116 (ROS 11/I-68)		-	2	-	-	3	-	-	1xMCB 16 A 3P-C 2xMCB 16 A 1P-B	5 x 6 mm ² M 32	InA 32 A	1
202117 (ROS 11/I-68/S)		-	2	-	-	-	3	-	1xMCB 16 A 3P-C 2xMCB 16 A 1P-B	5 x 6 mm ² M 32	InA 32 A	1
202118 (ROS 11/I-61)		-	-	1	1	4	-	-	1xMCB 16 A 3P-C 2xMCB 16 A 1P-B	5 x 6 mm ² M 32	InA 32 A	1
202119 (ROS 11/I-61/S)		-	-	1	1	-	4	-	1xMCB 16 A 3P-C 1xMCB 32 A 3P-C 2xMCB 16 A 1P-B	5 x 6 mm ² M 32	InA 40 A	1
202120 (ROS 11/I-62)		-	-	1	1	4	-	-	1xMCB 16 A 3P-C 1xMCB 32 A 3P-C 2xMCB 16 A 1P-B	5 x 6 mm ² M 32	InA 40 A	1
202121 (ROS 11/I-62/S)		-	-	1	1	-	4	-	1xMCB 16 A 3P-C 1xMCB 32 A 3P-C 4xMCB 16 A 1P-B	5 x 6 mm ² M 32	InA 40 A	1
202122 (ROS 11/I-63)		-	-	1	1	4	-	-	1xMCB 16 A 3P-C 1xMCB 32 A 3P-C 4xMCB 16 A 1P-B	5 x 6 mm ² M 32	InA 40 A	1
202123 (ROS 11/I-63/S)		-	-	1	1	-	4	-	1xMCB 16 A 3P-C 1xMCB 32 A 3P-C 4xMCB 16 A 1P-B	5 x 6 mm ² M 32	InA 40 A	1

InA = Rated current of switchgear and control gear assembly



Distribution boxes ROS 11 IP54 without MCBs, fully pre -wired

- Designed for wall mounting as part of a fixed wiring.
- Distribution boxes do not require any maintenance after installation.
- Cover resistant against excessive heat and fire (650 °C glow wire test).
- Ord. No. 202168, 22169 with safety toroidal transformer (SELV) 24 V AC/150 VA.
- Pre-injected centric circles for glands on top: 2x (M25; M32); bottom and rear: 1x (M25; M32).
- Dimensions 343 x 241 x 163 mm (h x w x d).

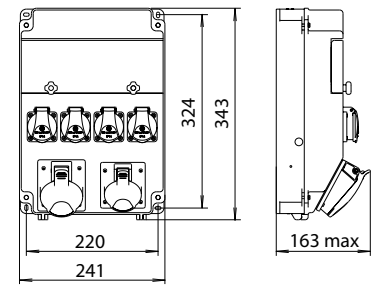

Complies with standards: STN EN 61439-1, STN EN 61439-3
 Mechanical resistance of box: IK10
 Degree of protection: IP54
 Material: ABS
 Nominal working voltage: 400 V-, 250 V-, 50/60 Hz
 Operating temperature: -25 °C to +55 °C

202156

Ord. No. (Type)	Layout	CEE 400 V 5P		CEE 400 V 4P		250 V		Protection		Connection	InA	Pkg (pcs.)
		32 A	16 A	32 A	16 A	16 A Fr	16 A Sch	RCCB	MCBs			
202150 (ROS 11/x-01)		4	-	-	-	-	-	-	-	5 x 6 mm ² M 32	InA 40 A	4
202152 (ROS 11/x-03)		-	4	-	-	-	-	-	-	5 x 6 mm ² M 32	InA 16 A	4
202154 (ROS 11/x-05)		2	2	-	-	-	-	-	-	5 x 6 mm ² M 32	InA 16 A	4
202156 (ROS 11/x-11)		2	1	-	-	2	-	-	-	5 x 6 mm ² M 32	InA 32 A	4
202157 (ROS 11/x-11/S)		-	-	-	-	-	2	-	-	-	-	1
202158 (ROS 11/x-14)		1	2	-	-	2	-	-	-	5 x 6 mm ² M 32	InA 32 A	4
202159 (ROS 11/x-14/S)		-	-	-	-	-	2	-	-	-	-	1
202160 (ROS 11/x-65)		1	1	-	-	2	-	-	-	5 x 6 mm ² M 32	InA 40 A	4
202161 (ROS 11/x-65/S)		-	-	-	-	-	2	-	-	-	-	1
202162 (ROS 11/x-632)		1	1	-	-	2	-	-	-	5 x 6 mm ² M 32	InA 40 A	4
202163 (ROS 11/x-632/S)		-	-	-	-	-	2	-	-	-	-	1
202164 (ROS 11/x-66)		2	-	-	-	2	-	-	-	5 x 6 mm ² M 32	InA 40 A	4
202165 (ROS 11/x-66/S)		-	-	-	-	-	2	-	-	-	-	1
202166 (ROS 11/x-64)		-	2	-	-	2	-	-	-	5 x 6 mm ² M 32	InA 32 A	4
202167 (ROS 11/x-64/S)		-	-	-	-	-	2	-	-	-	-	1

InA = Rated current of switchgear and control gear assembly





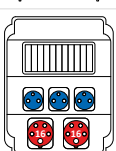
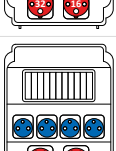

Distribution boxes ROS 11 IP54 without MCBs, fully pre-wired (continued)

Ord. No. (Type)	Layout	CEE 400 V 5P		CEE 400 V 4P		250 V		Protection		Connection	InA	Pkg (pcs.)
		32 A	16 A	32 A	16 A	16 A Fr	16 A Sch	RCCB	MCBs			
202168 (ROS 11/x-32/24 V)		1	1	-	-	2	-	-	-	5 x 6 mm ² M 32	InA 16 A	4
202169 (ROS 11/x-32/24 V/S)						-	2					1 x 24 V/10 A
202170 (ROS 11/x-67)		1	1	-	-	3	-	-	-	5 x 6 mm ² M 32	InA 40 A	4
202171 (ROS 11/x-67/S)						-	3					1 x 24 V/10 A
202172 (ROS 11/x-68)		-	2	-	-	3	-	-	-	5 x 6 mm ² M 32	InA 32 A	4
202173 (ROS 11/x-68/S)						-	3					1
202174 (ROS 11/x-70)		-	1	-	-	3	-	-	-	5 x 6 mm ² M 32	InA 32 A	4
202175 (ROS 11/x-70/S)						-	3					1
202176 (ROS 11/x-69)		2	-	-	-	3	-	-	-	5 x 6 mm ² M 32	InA 40 A	4
202177 (ROS 11/x-69/S)						-	3					1
202178 (ROS 11/x-21)		1	1	-	-	4	-	-	-	5 x 6 mm ² M 32	InA 32 A	4
202179 (ROS 11/x-21/S)						-	4					1
202180 (ROS 11/x-22)		2	-	-	-	4	-	-	-	5 x 6 mm ² M 32	InA 40 A	4
202181 (ROS 11/x-22/S)						-	4					1
202182 (ROS 11/x-23)		-	2	-	-	4	-	-	-	5 x 6 mm ² M 32	InA 40 A	4
202183 (ROS 11/x-23/S)						-	4					1
202184 (ROS 11/x-25)		-	-	-	-	7	-	-	-	5 x 6 mm ² M 32	InA 32 A	4
202185 (ROS 11/x-25/S)						-	7					1
202186 (ROS 11/x-41)		-	-	4	-	-	-	-	-	5 x 6 mm ² M 32	InA 32 A	4
202188 (ROS 11/x-43)		-	-	-	4	-	-	-	-	5 x 6 mm ² M 32	InA 16 A	4
202190 (ROS 11/x-45)		-	-	2	2	-	-	-	-	5 x 6 mm ² M 32	InA 16 A	4

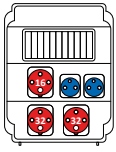
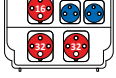
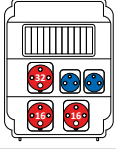
InA = Rated current of switchgear and control gear assembly

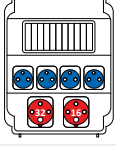
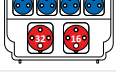
Distribution boxes ROS 11 IP54 without MCBs, fully pre-wired (continued)

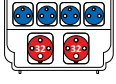
Ord. No. (Type)	Layout	CEE 400 V 5P		CEE 400 V 4P		250 V		Protection		Connection	InA	Pkg (pcs.)
		32 A	16 A	32 A	16 A	16 A Fr	16 A Sch	RCCB	MCBs			
202192 (ROS 11/x-51)		-	-	2	1	2	-	-	-	5 x 6 mm ² M 32	InA 32 A	4
202193 (ROS 11/x-51/S)		-	-	2	1	-	2	-	-			1
202194 (ROS 11/x-54)		-	-	1	2	2	-	-	-	5 x 6 mm ² M 32	InA 32 A	4
202195 (ROS 11/x-54/S)		-	-	1	2	-	2	-	-			1
202196 (ROS 11/x-61)		-	-	1	1	4	-	-	-	5 x 6 mm ² M 32	InA 32 A	4
202197 (ROS 11/x-61/S)		-	-	1	1	-	4	-	-			1
202198 (ROS 11/x-62)		-	-	2	-	4	-	-	-	5 x 6 mm ² M 32	InA 40 A	4
202199 (ROS 11/x-62/S)		-	-	2	-	-	4	-	-			4

InA = Rated current of switchgear and control gear assembly







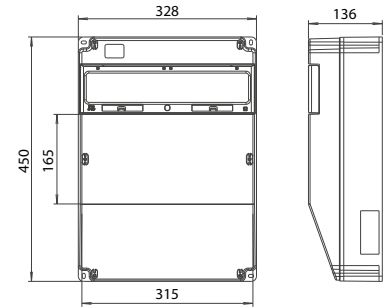















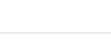
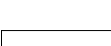





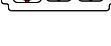

Distribution boxes ROS 16 IP54 a IP66

- ROS 16/FI -Standard = distribution boxes are fully equipped with the necessary MCBs and RCCB.
- ROS 16/I - Economic= basic number MCBs.
- ROS 16/x - Unprotected = without MCBs, precabling ready for installation MCBs according to the Standard version.
- Designed for wall mounting as part of a fixed wiring.
- Cover resistant against excessive heat and fire (650 °C).
- Pre-injected centric circles for glands from top and bottom: 2x (M32; M40), 1x (M25; M32; M40; M50); rear 1x (23.5 to 52.5 mm).
- Supplied gland M 40 in combinations without inlet.
- Max. cable entry: 5 x 25 mm²
- Dimensions 450 x 328 x 136 mm (h x w x d).



Complies with standards:: STN EN 61439-1, STN EN 61439-3
 Mechanical resistance of box: IK10
 Material: ABS
 Nominal working voltage: 400 V~, 250 V~, 50/60 Hz
 Operating temperature: -25 °C to +55 °C

203080

Ord. No. (Type)	Layout	CEE 400 V 5P			250 V		Main switch 63 A	RCCB 63 A/4/0,03 A	MCBs			Connection	Degree of protection	InA	RDF	Pkg (pcs.)
		63 A	32 A	16 A	16 A Fr	16 A Sch			32 A 3P-C	16 A 3P-C	16 A 1P-B					
203000 (ROS 16/FI-103)					4	-										
203001 (ROS 16/FI-103/S)					-	4		1	1	1	4	5 x 16 mm ² M40	IP54	InA 63 A	0,6	1
203002 (ROS 16/I-103)		-	1	1	4	-	-	-	1	1	2				1,0	
203003 (ROS 16/I-103/S)					4	-									0,6	
203004 (ROS 16/x-103)					-	4									0,6	
203005 (ROS 16/x-103/S)					6	-		1	1	1	6				0,6	
203006 (ROS 16/FI-104)					-	6									0,6	1
203007 (ROS 16/FI-104/S)		-	1	1	6	-	-	-	1	1	3	5 x 16 mm ² M40	IP54	InA 63 A	1,0	
203008 (ROS 16/I-104)					6	-									0,6	
203009 (ROS 16/I-104/S)					-	6									0,6	
203010 (ROS 16/x-104)					6	-									0,6	
203011 (ROS 16/x-104/S)					-	6									0,6	
203012 (ROS 16/FI-108)					12	-		1	1	1	6				0,6	1
203013 (ROS 16/FI-108/S)		-	1	1	-	12	-	-	1	1	4	5 x 16 mm ² M40	IP54	InA 63 A	0,8	
203014 (ROS 16/I-108)					12	-									0,6	
203015 (ROS 16/I-108/S)					-	12									0,6	
203016 (ROS 16/x-108)					12	-									0,6	
203017 (ROS 16/x-108/S)					-	12									0,6	
203018 (ROS 16/FI-111)					4	-		1	1	2	2				0,6	1
203019 (ROS 16/FI-111/S)		-	1	2	-	4	-	-	1	1	2	5 x 16 mm ² M40	IP54	InA 63 A	1,0	
203020 (ROS 16/I-111)					4	-									0,6	
203021 (ROS 16/I-111/S)					-	4									0,6	
203022 (ROS 16/x-111)					4	-									0,6	
203023 (ROS 16/x-111/S)					-	4									0,6	
203024 (ROS 16/FI-112)					6	-		1	1	2	3				0,6	1
203025 (ROS 16/FI-112/S)		-	1	2	-	6	-	-	1	1	3	5 x 16 mm ² M40	IP54	InA 63 A	1,0	
203026 (ROS 16/I-112)					6	-									0,6	
203027 (ROS 16/I-112/S)					-	6									0,6	
203028 (ROS 16/x-112)					6	-									0,6	
203029 (ROS 16/x-112/S)					-	6									0,6	
203030 (ROS 16/FI-117)					4	-		1	2	1	2				0,5	1
203031 (ROS 16/FI-117/S)		-	2	1	-	4	-	-	1	1	2	5 x 16 mm ² M40	IP54	InA 63 A	1,0	
203032 (ROS 16/I-117)					4	-									0,5	
203033 (ROS 16/I-117/S)					-	4									0,5	
203034 (ROS 16/x-117)					4	-									0,6	
203035 (ROS 16/x-117/S)					-	4									0,6	
203036 (ROS 16/FI-123)					4	-		1	1	2	2				0,6	1
203037 (ROS 16/FI-123/S)		-	2	2	-	4	-	-	1	1	2	5 x 16 mm ² M40	IP54	InA 63 A	1,0	
203038 (ROS 16/I-123)					4	-									0,6	
203039 (ROS 16/I-123/S)					-	4									0,6	
203040 (ROS 16/x-123)					4	-									0,6	
203041 (ROS 16/x-123/S)					-	4									0,6	

RDF = Rated diversity factor, InA = Rated current of switchgear and control gear assembly

Distribution boxes ROS 16 IP54 and IP66 (continued)

Ord. No. (Type)	Layout	CEE 400 V 5P			250 V		Main switch 63 A	RCCB 63 A/4/0,03 A	MCBs			Connection	Degree of protection	InA	RDF	Pkg (pcs.)
		63 A	32 A	16 A	16 A Fr	16 A Sch			32 A 3P-C	16 A 3P-C	16 A 1P-B					
203042 (ROS 16/FI-128)					3	-		1	1	2	3	5 x 16 mm ² M40	IP54	InA 63 A	1,0	1
203043 (ROS 16/FI-128/S)					-	3										
203044 (ROS 16/I-128)					3	-										
203045 (ROS 16/I-128/S)			2	3	-	3			1	1	3					
203046 (ROS 16/x-128)					3	-										
203047 (ROS 16/x-128/S)					-	3					0,6					
203048 (ROS 16/FI-134)					15	-		1	-	-	10	5 x 16 mm ² M40	IP54	InA 63 A	1,0	1
203049 (ROS 16/FI-134/S)					-	15										
203050 (ROS 16/I-134)					15	-					5					
203051 (ROS 16/I-134/S)					-	15										
203052 (ROS 16/x-134)					15	-										
203053 (ROS 16/x-134/S)					-	15					0,8					

RDF = Rated diversity factor, InA = Rated current of switchgear and control gear assembly

with 63 A socket

Ord. No. (Type)	Layout	CEE 400 V 5P			250 V		Main switch 63 A	RCCB 63 A/4/0,03 A	MCBs			Connection	Degree of protection	InA	RDF	Pkg (pcs.)	
		63 A	32 A	16 A	16 A Fr	16 A Sch			32 A 3P-C	16 A 3P-C	16 A 1P-B						
203070 (ROS 16/FI-203)					4	-		1	1	1	4	5 x 16 mm ² M40	IP54	InA 63 A	0,5	1	
203071 (ROS 16/FI-203/S)					-	4											
203072 (ROS 16/I-203)					4	-											
203073 (ROS 16/I-203/S)			1	1	1	-	4			1	1						2
203074 (ROS 16/x-203)						4	-										
203075 (ROS 16/x-203/S)					-	4						0,4					
203076 (ROS 16/FI-206)					10	-		1	1	1	5	5 x 16 mm ² M40	IP54	InA 63 A	0,5	1	
203077 (ROS 16/FI-206/S)					-	10											
203078 (ROS 16/I-206)					10	-											
203079 (ROS 16/I-206/S)			1	1	1	-	10			1	1						3
203080 (ROS 16/x-206)						10	-										
203081 (ROS 16/x-206/S)					-	10						0,4					
203082 (ROS 16/FI-209)					4	-		1	1	2	2	5 x 16 mm ² M40	IP54	InA 63 A	0,5	1	
203083 (ROS 16/FI-209/S)					-	4											
203084 (ROS 16/I-209)					4	-											
203085 (ROS 16/I-209/S)			1	1	2	-	4			1	1						2
203086 (ROS 16/x-209)						4	-										
203087 (ROS 16/x-209/S)					-	4						0,4					
203088 (ROS 16/FI-215)					4	-		1	2	1	2	5 x 16 mm ² M40	IP54	InA 63 A	0,5	1	
203089 (ROS 16/FI-215/S)					-	4											
203090 (ROS 16/I-215)					4	-											
203091 (ROS 16/I-215/S)			1	2	1	-	4			1	1						2
203092 (ROS 16/x-215)						4	-										
203093 (ROS 16/x-215/S)					-	4						0,3					
203094 (ROS 16/FI-221)					4	-		1	1	2	2	5 x 16 mm ² M40	IP54	InA 63 A	0,5	1	
203095 (ROS 16/FI-221/S)					-	4											
203096 (ROS 16/I-221)					4	-											
203097 (ROS 16/I-221/S)			1	2	2	-	4			1	1						2
203098 (ROS 16/x-221)						4	-										
203099 (ROS 16/x-221/S)					-	4						0,4					
203100 (ROS 16/FI-225)					3	-		1	1	2	3	5 x 16 mm ² M40	IP54	InA 63 A	0,5	1	
203101 (ROS 16/FI-225/S)					-	3											
203102 (ROS 16/I-225)					3	-											
203103 (ROS 16/I-225/S)			1	2	3	-	3			1	1						3
203104 (ROS 16/x-225)						3	-										
203105 (ROS 16/x-225/S)					-	3						0,4					

RDF = Rated diversity factor, InA = Rated current of switchgear and control gear assembly



Distribution boxes ROS 16 IP54 and IP66 (continued)
with 63 A straight inlet

Ord. No. (Type)	Layout	CEE 400 V 5P			250 V		Main switch 63 A	RCCB 63 A/4/0,03 A	MCBs			Connection CEE inlet 63 A/5P/400 V	Degree of protection IP54	InA InA 63 A	RDF	Pkg (pcs.)	
		63 A	32 A	16 A	16 A Fr	16 A Sch			32 A 3P-C	16 A 3P-C	16 A 1P-B						
203130 (ROS 16/FI-304)					6	-		1	1	1	6				0,6	1	
203131 (ROS 16/FI-304/S)					-	6											
203132 (ROS 16/I-304)					6	-											
203133 (ROS 16/I-304/S)			1	1	1	-	6		-	1	1						3
203134 (ROS 16/x-304)						6	-										
203135 (ROS 16/x-304/S)						-	6										

RDF = Rated diversity factor, InA = Rated current of switchgear and control gear assembly

with 63 A switch

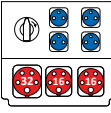
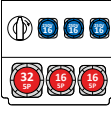
Ord. No. (Type)	Layout	CEE 400 V 5P			250 V		Main switch 63 A	RCCB 63 A/4/0,03 A	MCBs			Connection 5 x 16 mm ² M40	Degree of protection IP54	InA InA 63 A	RDF	Pkg (pcs.)	
		63 A	32 A	16 A	16 A Fr	16 A Sch			32 A 3P-C	16 A 3P-C	16 A 1P-B						
203150 (ROS 16/FI-412)					4	-		1	1	2	2				0,6	1	
203151 (ROS 16/FI-412/S)					-	4											
203152 (ROS 16/I-412)					4	-											
203153 (ROS 16/I-412/S)			-	1	2	-	4		-	1	1						2
203154 (ROS 16/x-412)						4	-										
203155 (ROS 16/x-412/S)						-	4										
203156 (ROSG 16/FI-411)					3	-		1	1	2	2				0,6	1	
203157 (ROSG 16/FI-411/S)					-	3											
203158 (ROSG 16/I-411)					3	-											
203159 (ROSG 16/I-411/S)			-	1	2	-	3		-	1	1						3
203160 (ROSG 16/x-411)						3	-										
203161 (ROSG 16/x-411/S)						-	3										

RDF = Rated diversity factor, InA = Rated current of switchgear and control gear assembly

with 63 A switch and inlet

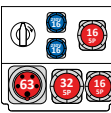
Ord. No. (Type)	Layout	CEE 400 V 5P			250 V		Main switch 63 A	RCCB 63 A/4/0,03 A	MCBs			Connection CEE inlet 63 A/5P/400 V	Degree of protection IP54	InA InA 63 A	RDF	Pkg (pcs.)	
		63 A	32 A	16 A	16 A Fr	16 A Sch			32 A 3P-C	16 A 3P-C	16 A 1P-B						
203180 (ROS 16/FI-516)					4	-		1	1	2	2				0,6	1	
203181 (ROS 16/FI-516/S)					-	4											
203182 (ROS 16/I-516)					4	-											
203183 (ROS 16/I-516/S)			-	2	2	-	4		-	1	1						2
203184 (ROS 16/x-516)						4	-										
203185 (ROS 16/x-516/S)						-	4										
203186 (ROSG 16/FI-506)					2	-		1	1	2	2				0,6	1	
203187 (ROSG 16/FI-506/S)					-	2											
203188 (ROSG 16/I-506)					2	-											
203189 (ROSG 16/I-506/S)			-	1	2	-	2		-	1	1						1
203190 (ROSG 16/x-506)						2	-										
203191 (ROSG 16/x-506/S)						-	2										

RDF = Rated diversity factor, InA = Rated current of switchgear and control gear assembly

with 63 A socket, main switch, straight inlet and the possibility of looping

Ord. No. (Type)	Layout	CEE 400 V 5P			250 V		Main switch 63 A	RCCB 63 A/4/0,03 A	MCBs			Connection CEE inlet 63 A/5P/400 V	Degree of protection IP54	InA InA 63 A	RDF	Pkg (pcs.)	
		63 A	32 A	16 A	16 A Fr	16 A Sch			32 A 3P-C	16 A 3P-C	16 A 1P-B						
203200 (ROS 16/FI-603)					4	-		1	1	1	4				0,4	1	
203201 (ROS 16/FI-603/S)					-	4											
203202 (ROS 16/I-603)					4	-											
203203 (ROS 16/I-603/S)			1	1	1	-	4		-	1	1						2
203204 (ROS 16/x-603)						4	-										
203205 (ROS 16/x-603/S)						-	4										

RDF = Rated diversity factor, InA = Rated current of switchgear and control gear assembly

Distribution boxes on stand ROS 11S IP54 with RCCB

- Using in exterior or interior, residential sector, building sites and industrial zones.
- Cover resistant against excessive heat and fire (650 °C glow wire test).
- Pre-injected centric circles for glands on top: 2x (M25; M32); bottom and rear: 1x (M25; M32).
- Dimensions 737 x 344 x 262/518 mm (h x w x d).



204000

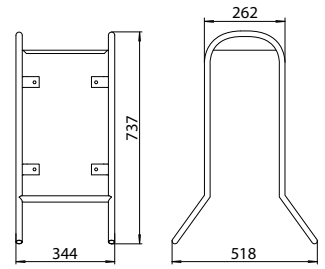

Complies with standards: STN EN 61439-1, STN EN 61439-3
 Mechanical resistance of box: IK10
 Degree of protection: IP54
 Material: ABS
 Nominal working voltage: 400 V~, 250 V~, 50/60 Hz
 Operating temperature: -25 °C to +55 °C

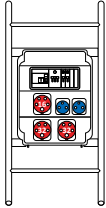
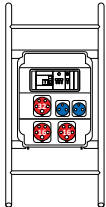
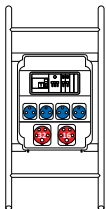
Ord. No. (Type)	Layout	CEE 400 V 5P		CEE 400 V 4P		250 V		Protection		Connection	InA	RDF	Pkg (pcs.)
		32 A	16 A	32 A	16 A	16 A Fr	16 A Sch	RCCB	MCBs				
204000 (ROS 11S/FI-12)		2	1	-	-	2	-	1xRCCB 40 A/4/0,03 A (Type A)	1xMCB 16 A 3P-C 2xMCB 16 A 1P-B	5 x 6 mm ² M 32	InA 32 A	0,5	1
204001 (ROS 11S/FI-12/S)	-					2							
204002 (ROS 11S/FI-14)		1	2	-	-	2	-	1xRCCB 40 A/4/0,03 A (Type A)	1xMCB 16 A 3P-C 1xMCB 16 A 1P-B	5 x 6 mm ² M 32	InA 32 A	0,5	1
204003 (ROS 11S/FI-14/S)	-					2							
204004 (ROS 11S/FI-21)		1	1	-	-	4	-	1xRCCB 40 A/4/0,03 A (Type A)	1xMCB 16 A 3P-C 2xMCB 16 A 1P-B	5 x 6 mm ² M 32	InA 32 A	0,5	1
204005 (ROS 11S/FI-21/S)	-					4							

RDF = Rated diversity factor, InA = Rated current of switchgear and control gear assembly



DISTRIBUTION BOXES

Building distribution boxes 11 modules

CONNECTING ENERGY



Distribution boxes on stand ROS 11S IP54 with RCCB and supply cable

- Using in exterior or interior, residential sector, building sites and industrial zones.
- Cover resistant against excessive heat and fire (650 °C glow wire test).
- Supply cable 2 m terminated with a plug 32 A/5P/400 V.
- Pre-injected centric circles for glands on top: 2x (M25; M32); bottom and rear: 1x (M25; M32).
- Dimensions 737 x 344 x 262/518 mm (h x w x d).

Complies with standards: STN EN 61439-1, STN EN 61439-3
 Mechanical resistance of box: IK10
 Degree of protection: IP54
 Material: ABS
 Nominal working voltage: 400 V~, 250 V~, 50/60 Hz
 Operating temperature: -25 °C to +55 °C



204020

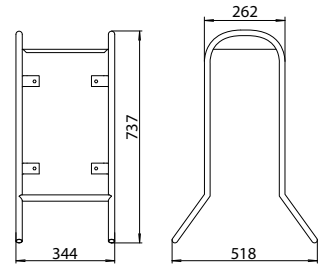

Ord. No. (Type)	Layout	CEE 400 V 5P		CEE 400 V 4P		250 V		Protection		Connection	InA RDF	RDF	Pkg (pcs.)
		32 A	16 A	32 A	16 A	16 A Fr	16 A Sch	RCCB	MCBs				
204020 (ROS 11S/FI-12/P)		2	1	-	-	2	-	1xRCCB 40 A/4/0,03 A (Type A)	1xMCB 16 A 3P-C 2xMCB 16 A 1P-B	cable 2 m with plug 32 A/5P/400 V	InA 32 A	0,5	1
204021 (ROS 11S/FI-12/P/S)						-	2						
204022 (ROS 11S/FI-14/P)		1	2	-	-	2	-	1xRCCB 40 A/4/0,03 A (Type A)	1xMCB 16 A 3P-C 1xMCB 16 A 1P-B	cable 2 m with plug 32 A/5P/400 V	InA 32 A	0,5	1
204023 (ROS 11S/FI-14/P/S)						-	2						
204024 (ROS 11S/FI-21/P)		1	1	-	-	4	-	1xRCCB 40 A/4/0,03 A (Type A)	1xMCB 16 A 3P-C 2xMCB 16 A 1P-B	cable 2 m with plug 32 A/5P/400 V	InA 32 A	0,5	1
204025 (ROS 11S/FI-21/P/S)						-	4						

RDF = Rated diversity factor, InA = Rated current of switchgear and control gear assembly



DISTRIBUTION BOXES

Building distribution boxes 12 modules

CONNECTING ENERGY



Portable distribution boxes ROS 12SD IP44, handle

- Distribution boxes with handle have been designed to be part of mobile wiring.
- Using in exterior or interior, residential sector, building sites and industrial zones.
- Cover resistant against excessive heat and fire (650 °C glow wire test).
- Pre-injected centric circles for glands bottom: 1x (M25; M32).
- Dimensions 385 x 195 x 215 (h x w x d).



204040

Complies with standards:	STN EN 61439-1, STN EN 61439-3
Mechanical resistance of box:	IK08
Degree of protection:	IP44
Material:	ABS
Nominal working voltage:	400 V~, 250 V~, 50/60 Hz
Operating temperature:	-25 °C to +55 °C

Ord. No. (Type)	Layout	CEE 400 V 5P		CEE 400 V 4P		250 V		Protection		Connection	InA	RDF	Pkg (pcs.)
		32 A	16 A	32 A	16 A	16 A Fr	16 A Sch	RCCB	MCBs				
204040 (ROS 12SD/FI-21/P)		1	1	-	-	4	-	1xRCCB 40 A/4/0,03 A (Type A)	1xMCB 16 A 3P-C 2xMCB 16 A 1P-B	cable 2 m with plug 32 A/5P/400 V	InA 32 A	0,5	1
204041 (ROS 12SD/FI-21/P/S)						-	4						
204042 (ROS 12SD/FI-27/P)		-	-	-	-	6	-	1xRCCB 40 A/4/0,03 A (Type A)	3xMCB 16 A 1P-B	cable 2 m with plug 16 A/5P/400 V	InA 16 A	0,5	1
204043 (ROS 12SD/FI-27/P/S)						-	6						
204044 (ROS 12SD/23/P)		-	2	-	-	4	-	-	-	cable 2 m with plug 16 A/5P/400 V	InA 16 A	0,25	1
204045 (ROS 12SD/23/P/S)						-	4						
204046 (ROS 12SD/24/PR)		-	1	-	-	4	-	-	-	CEE inlet 16 A/5P/400 V	InA 16 A	0,35	1
204047 (ROS 12SD/24/PR/S)						-	4						

RDF = Rated diversity factor, InA = Rated current of switchgear and control gear assembly



DISTRIBUTION BOXES

Building distribution boxes 16 modules

CONNECTING ENERGY



Distribution boxes on stand ROS 16S IP54 and IP66 with RCCB

- ROS 16S/FI - Standard = distribution boxes are fully equipped with the necessary MCBs and RCCB.
- Distribution boxes with handle have been designed to be part of mobile wiring.
- Using in exterior or interior, residential sector, building sites and industrial zones.
- Cover resistant against excessive heat and fire (650 °C glow wire test).
- Possibility of locking in position 0.
- Pre-injected centric circles for glands from top and bottom: 2x(M32; M40), 1x(M25; M32; M40; M50); rear 1x (23,5 to 52,5 mm).
- Supplied gland M 40 in combinations without inlet.
- Max. cable entry: 5 x 25 mm².
- Dimensions 817 x 400 x 262/518 mm (h x w x d).

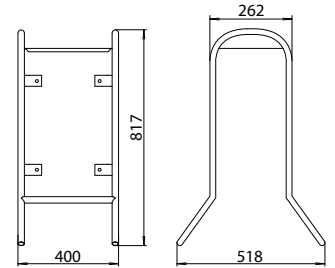

Complies with standards::	STN EN 61439-1, STN EN 61439-3
Mechanical resistance of box:	IK08
Material:	ABS
Nominal working voltage:	400 V~, 250 V~, 50/60 Hz
Operating temperature:	-25 °C to +55 °C

with 63 A switch

Ord. No. (Type)	Layout	CEE 400 V 5P			250 V		Main switch	RCCB	MCBs			Degree of protection	InA	RDF	Pkg (pcs.)
		63 A	32 A	16 A	16 A Fr	16 A Sch	63 A	63 A/4/0,03 A	32 A 3P-C	16 A 3P-C	16 A 1P-B				
204060 (ROS 16S/FI-425)		-	2	3	3	-	1	1	1	2	3	IP54	InA 63 A	0,6	1
204061 (ROS 16S/FI-425/S)		-	2	3	-	3	1	1	1	2	3	IP54	InA 63 A	0,6	1
204062 (ROSG 16S/FI-412)		-	1	2	4	-	1	1	1	2	3	IP66	InA 63 A	0,6	1
204063 (ROSG 16S/FI-412/S)		-	1	2	-	4	1	1	1	2	3	IP66	InA 63 A	0,6	1

RDF = Rated diversity factor, InA = Rated current of switchgear and control gear assembly

with 63 A switch and inlet

Ord. No. (Type)	Layout	CEE 400 V 5P			250 V		Main switch	RCCB	MCBs			Degree of protection	InA	RDF	Pkg (pcs.)
		63 A	32 A	16 A	16 A Fr	16 A Sch	63 A	63 A/4/0,03 A	32 A 3P-C	16 A 3P-C	16 A 1P-B				
204070 (ROS 16S/FI-506)		-	1	2	2	-	1	1	1	2	2	IP54	InA 63 A	0,6	1
204071 (ROS 16S/FI-506/S)		-	1	2	-	2	1	1	1	2	2	IP54	InA 63 A	0,6	1
204072 (ROSG 16S/FI-506)		-	1	2	2	-	1	1	1	2	2	IP66	InA 63 A	0,6	1
204073 (ROSG 16S/FI-506/S)		-	1	2	-	2	1	1	1	2	2	IP66	InA 63 A	0,6	1

RDF = Rated diversity factor, InA = Rated current of switchgear and control gear assembly

with 63 A socket, main switch, straight inlet and the possibility of looping

Ord. No. (Type)	Layout	CEE 400 V 5P			250 V		Main switch	RCCB	MCBs			Degree of protection	InA	RDF	Pkg (pcs.)
		63 A	32 A	16 A	16 A Fr	16 A Sch	63 A	63 A/4/0,03 A	32 A 3P-C	16 A 3P-C	16 A 1P-B				
204080 (ROS 16S/FI-601)		1	1	1	2	-	1	1	1	1	2	IP54	InA 63 A	0,4	1
204081 (ROS 16S/FI-601/S)		1	1	1	-	2	1	1	1	1	2	IP54	InA 63 A	0,4	1
204082 (ROSG 16S/FI-601)		1	1	1	2	-	1	1	1	1	2	IP66	InA 63 A	0,4	1
204083 (ROSG 16S/FI-601/S)		1	1	1	-	2	1	1	1	1	2	IP66	InA 63 A	0,4	1

RDF = Rated diversity factor, InA = Rated current of switchgear and control gear assembly







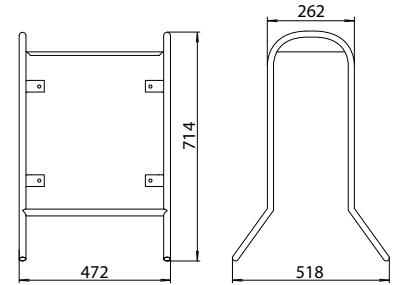

Distribution boxes on stand ROS 12S IP54 with RCCB and switch

- Distribution boxes with handle have been designed to be part of mobile wiring.
- Using in exterior or interior, residential sector, building sites and industrial zones.
- Cover resistant against excessive heat and fire (650 °C glow wire test).
- Possibility of locking in position 0.
- Dimensions 714 x 472 x 262/518 mm (h x w x d).



Complies with standards::	STN EN 61439-1, STN EN 61439-3
Mechanical resistance of box:	IK10
Degree of protection:	IP65 - Ord. No. 204120, 204121 IP54
Material:	Glass fiber reinforced polyester
Flammability resistance:	UL94 -V0
Resistance to pressure:	200 N/mm ²
Nominal working voltage:	400 V~, 250 V~, 50/60 Hz
Operating temperature:	-25 °C to +55 °C



204104

Ord. No. (Type)	Layout	CEE 400 V 5P		CEE 400 V 4P		250 V		Protection		Connection	InA	RDF	Pkg (pcs.)
		32 A	16 A	32 A	16 A	16 A Fr	16 A Sch	RCCB	MCBs				
204100 (ROS 12S/FI-01)		1	1	-	-	2	-	1xRCCB 63 A/4/0,03 A (Type A)	1xMCB 32 A 3P-C 1xMCB 16 A 3P-C 2xMCB 16 A 1P-B	5 x 10 mm ² M 32	InA 63 A	0,8	1
204101 (ROS 12S/FI-01/S)						-	2						
204102 (ROS 12S/FI-02)			2	-	-	2	-	1xRCCB 63 A/4/0,03 A (Type A)	2xMCB 16 A 3P-C 2xMCB 16 A 1P-B	5 x 10 mm ² M 32	InA 63 A	1,0	1
204103 (ROS 12S/FI-02/S)						-	2						
204104 (ROS 12S/FI-03)		1	1	-	-	6	-	1xRCCB 63 A/4/0,03 A (Type A)	1xMCB 32 A 3P-C 1xMCB 16 A 3P-C 2xMCB 16 A 1P-B	CEE inlet 63 A/5P/400 V	InA 63 A	0,8	1
204105 (ROS 12S/FI-03/S)						-	6						

RDF = Rated diversity factor, InA = Rated current of switchgear and control gear assembly

Distribution boxes on stand ROS 12SG IP65 with RCCB and switch

- Distribution boxes with IP65 protection, other product features identical to **distribution boxes ROS 12S IP54 with RCCB and switch**.

Ord. No. (Type)	Layout	CEE 400 V 5P		CEE 400 V 4P		250 V		Protection		Connection	InA	RDF	Pkg (pcs.)
		32 A	16 A	32 A	16 A	16 A Fr	16 A Sch	RCCB	MCBs				
204120 (ROS 12SG/FI-04)		1	1	-	-	5	-	1xRCCB 63 A/4/0,03 A (Type A)	1xMCB 32 A 3P-C 1xMCB 16 A 3P-C 2xMCB 16 A 1P-B	CEE inlet 63 A/5P/400 V	InA 63 A	0,8	1
204121 (ROS 12SG/FI-04/S)						-	5						

RDF = Rated diversity factor, InA = Rated current of switchgear and control gear assembly



DISTRIBUTION BOXES

Building distribution boxes - 24 modules

CONNECTING ENERGY



Distribution boxes on stand ROS 24S IP54 with RCCB and switch

- Distribution boxes with handle have been designed to be part of mobile wiring.
- Using in exterior or interior, residential sector, building sites and industrial zones.
- Cover resistant against excessive heat and fire (650 °C glow wire test).
- Possibility of locking in position 0.
- Dimensions 714 x 672 x 262/518 mm (h x w x d).

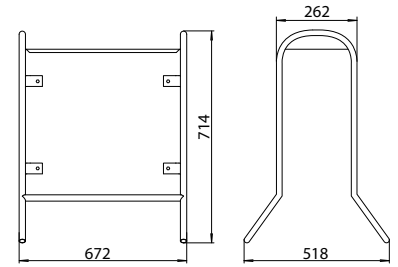

Complies with standards:	STN EN 61439-1, STN EN 61439-3
Mechanical resistance of box:	IK10
Degree of protection:	IP65 - Ord. No. 204160, 204161 IP54
Material:	Glass fiber reinforced polyester
Flammability resistance:	UL94 -V0
Resistance to pressure:	200 N/mm ²
Nominal working voltage:	400 V~, 250 V~, 50/60 Hz
Operating temperature:	-25 °C to +55 °C

204140

Ord. No. (Type)	Layout	CEE 400 V 5P		CEE 400 V 4P		CEE 230 V 3P		250 V		Protection		Connection	InA	RDF	Pkg (pcs.)
		32 A	16 A	32 A	16 A	32 A	16 A	16 A Fr	16 A Sch	RCCB	MCBs				
204140 (ROS 24S/FI-01)		2	2	-	-	-	-	4	-	1xRCCB 63 A/4/0,03 A (Type A)	2xMCB 32 A 3P-C 2xMCB 16 A 3P-C 4xMCB 16 A 1P-B	5 x 10 mm ² M 32	InA 63 A	0,4	1
204141 (ROS 242S/FI-01/S)								-	4						
204142 (ROS 24S/FI-02)		1	1	1	1	-	-	4	-	1xRCCB 63 A/4/0,03 A (Type A)	2xMCB 32 A 3P-C 2xMCB 16 A 3P-C 4xMCB 16 A 1P-B	5 x 10 mm ² M 32	InA 63 A	0,4	1
204143 (ROS 242S/FI-02/S)								-	4						

RDF = Rated diversity factor, InA = Rated current of switchgear and control gear assembly

Distribution boxes on stand ROS 24SG IP65 with RCCB, straight inlet and switch

- Distribution boxes with IP65 protection, other product features identical to **Distribution boxes ROS 24S IP54 with RCCB and switch**.

Ord. No. (Type)	Layout	CEE 400 V 5P		CEE 400 V 4P		CEE 230 V 3P		250 V		Protection		Connection	InA	RDF	Pkg (pcs.)
		32 A	16 A	32 A	16 A	32 A	16 A	16 A Fr	16 A Sch	RCCB	MCBs				
204160 (ROS 24SG/FI-03)		1	1	-	-	1	1	6	-	1xRCCB 63 A/4/0,03 A (Type A)	1xMCB 32 A 3P-C 1xMCB 16 A 3P-C 1xMCB 32 A 1P-C 1xMCB 16 A 1P-C 6xMCB 16 A 1P-B	CEE inlet 63 A/5P/400 V	InA 63 A	0,4	1
204161 (ROS 242SG/FI-03/S)								-	6						

RDF = Rated diversity factor, InA = Rated current of switchgear and control gear assembly



DISTRIBUTION BOXES

Semi-assemblies and spare parts

CONNECTING ENERGY



Unassembled semi-assemblies

- As an alternative to purchase of fully equipped distribution boxes for (4, 6, 7, 8, 11 and 16 modules) we offer the "unassembled" semi-assemblies without mounted sockets, MCBs and RCCB.





205004

Material:	ABS
Mechanical resistance of box:	IK10
Operating temperature:	-25 °C to +55 °C

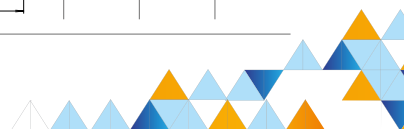
Ord. No. (Type)	Product view		Product view	Supplied accessories	Degree of protection	Dimension drawing	Dimensions (mm)		
							A (height)	B (width)	C (depth)
205000 (ROS 8/Z)			8 - modules	Box, 8-modules window, cable gland Pg 21, terminal block, Din rail TS35, cable clamp	IP44		260	190	84
205001 (ROS 4/Z)			4 - modules	Box, 4-modules window, cable gland Pg 21, terminal block, Din rail TS35, cable clamp	IP44		260	190	89
205002 (ROS /Z)			-	Box -plain surface, cable gland Pg 21, terminal block, DIN rail TS35, cable clamp	IP44		260	190	64
205003 (ROS 8/Z) - handle			8 - modules	Box with handle, 8-modules window, cable gland Pg 21, terminal block, DIN rail TS35, cable clamp	IP44		305	190	84
205004 (ROS 4/Z) - handle			4 - modules	Box with handle, 4-modules window, cable gland Pg 21, terminal block, DIN rail TS35, cable clamp	IP44		305	190	89
205005 (ROS /Z) - handle			-	Box -plain surface with handle, cable gland Pg 21, terminal block, DIN rail TS35, cable clamp	IP44		305	190	64
205006 (ROS 5-6/Z)			6 - modules	6-modules window, cable gland M 32, DIN rail TS 35, 5-pole terminal strip, 10 mm ² (6336-60), cable clamp	IP 54		343	136	122
205007 (ROS 7/Z)			7 - modules	7-modules window, gland M 32, DIN rail TS 35, switch carrying rail, 5-pole terminal strip, 10 mm ² (6336-60), cable clamp, does not contain a switch	IP54		263	241	121
205008 (ROS 11/Z)			11 - modules	11-modules window, cable gland M 32, DIN rail TS 35, 5-pole terminal block, 10 mm ² (6336-60), cable clamp	IP54		343	241	122

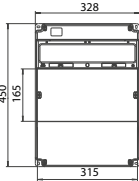

Unassembled semi-assemblies (continued)

Ord. No. (Type)	Product view		Product view	Supplied accessories	Degree of protection	Dimension drawing	Dimensions (mm)		
							A (height)	B (width)	C (depth)
205009 (ROS 16/Z)			16 - modules	16 - module window, bottom of distribution box, top cover of distribution box, DIN rail TS35 for MCBs, 12x 16 mm ² input busbar green (12/Z), 12 x 16 mm ² input busbar blue (12/N), cable clamp, 6 x screw KA 50 x 25 WN 1412, 4 x screw ISO 7049-ST 3,9 x 9,5; 2 x screw hardened 3,5 x 22, DIN rail TS 35, 5 x terminal block RS 25 (colour blue, green, white), side cover of terminal block, 2 x end clamp, cable gland M 40, bag PE 120 x 70, cardboard box 510 x 330 x 170	IP54				
205010 (ROSG 16/Z)			16 - modules	16 - module window, bottom of distribution box, top cover of distribution box, DIN rail TS35 for MCBs, sealing string IP65, 12x 16 mm ² input busbar green (12/Z), 12 x 16 mm ² input busbar blue (12/N), cable clamp, 6 x screw KA 50 x 25 WN 1412, 4 x screw ISO 7049-ST 3,9 x 9,5; 2 x screw hardened 3,5 x 22, DIN rail TS 35, 5 x terminal block RS 25 (colour blue, green, white), side cover of terminal block, 2 x end clamp, cable gland M 40, bag PE 120 x 70, cardboard box 510 x 330 x 170,	IP66				
205011 (ROS 16/ZB)			16 - modules	Bottom of distribution box, top cover of distribution box, DIN rail TS35 for MCBs, 12x 16 mm ² input busbar green (12/Z), 12 x 16 mm ² input busbar blue (12/N), cable clamp, 6 x screw KA 50 x 25 WN 1412, 2 x screw ISO 7049-ST 3,9 x 9,5; 2 x screw hardened 3,5 x 22, 1/2 5-pole terminal strip, 16 mm ² (6336-70), bag PE 120 x 70, cardboard box 510 x 330 x 170,,	IP54		450	328	136
205012 (ROSG 16/ZB)			16 - modules	Bottom of distribution box, top cover of distribution box, sealing string IP65, DIN rail TS35 for MCBs, 12x 16 mm ² input busbar green (12/Z), 12 x 16 mm ² input busbar blue (12/N), cable clamp, 6 x screw KA 50 x 25 WN 1412, 2 x screw ISO 7049-ST 3,9 x 9,5; 2 x screw hardened 3,5 x 22, 1/2 5-pole terminal strip, 16 mm ² (6336-70), bag PE 120 x 70, cardboard box 510 x 330 x 170,	IP66				
205013 (ROS 16/ZC)			16 - modules	Bottom of distribution box, top cover distribution box, DIN rail TS35 for MCBs, 6x screw KA 50 x 25 WN 1412, bag PE 120 x 70, cardboard box 510 x 330 x 170,	IP54				
205014 (ROSG 16/ZC)			16 - modules	Bottom of distribution box, top cover distribution box, sealing string IP65, DIN rail TS35 for MCBs, 6x screw KA 50 x 25 WN 1412, bag PE 120 x 70, cardboard box 510 x 330 x 170,	IP66				



**Mounting frame for panel socket
250 V / 16 A and 24 V / 10 A with
a mounting spacing of 38 x 38 mm.**

- For installation use a $\varnothing 4$ mm screw for plastics.
- Ord. No. 105761 for: Ord. No. 103750 to 103759, 103790 to 103793, 103830.

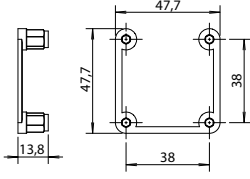
Ord. No. (Type)	Product view	Mounting holes
105761 (ND 105-2677)		

**Mounting frame for panel sockets
CEE 400 V / 16 A and 32 A with mounting
spacing 60 x 60 mm or 60 x 70 mm.**

- For installation use a $\varnothing 4$ mm screw for plastics.
- Ord. No. 105760 for : 104076, 104083, 104084, 104079, 104085, 104087, 104174, 104177, 104264, 104267, 104310 to 104315, 104329 to 104333, 104400, 104402, 104404 to 104406, 104408, 104410, 104411, 104414, 104416, 104417.

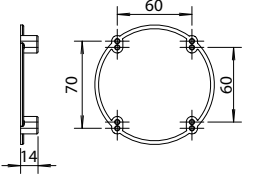
Ord. No. (Type)	Product view	Mounting holes
105760 (ND 105-2177)		

**Stand for building distribution boxes
ROS 11S**

- Dimensions 737 x 344 x 262/518 mm (h x w x d).

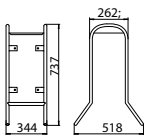
Ord. No. (Type)	Product view	Dimension drawing
205110 (ROS 11S)		

**Stand for building distribution boxes
ROS 16S**

- Dimensions 817 x 400 x 262/518 mm (h x w x d).

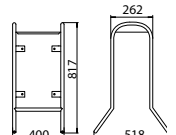
Ord. No. (Type)	Product view	Dimension drawing
205111 (ROS 16S)		

**Stand for building distribution boxes
ROS 12S**

- Dimensions 714 x 472 x 262/518 mm (h x w x d).

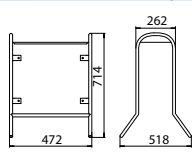
Ord. No. (Type)	Product view	Dimension drawing
205112 (ROS 12S)		

**Stand for building distribution boxes
ROS 24S**

- Dimensions 714 x 672 x 262/518 mm (h x w x d).

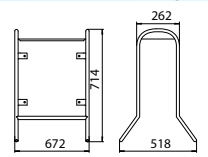
Ord. No. (Type)	Product view	Dimension drawing
205113 (ROS 24S)		



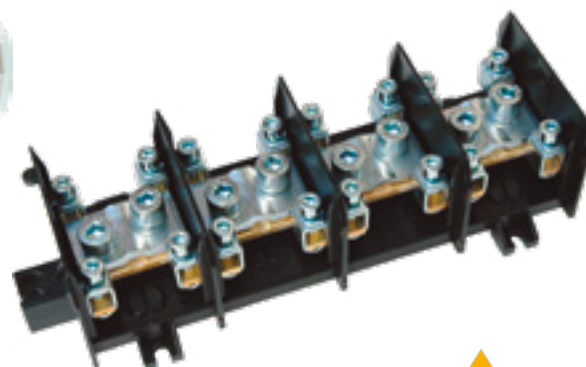
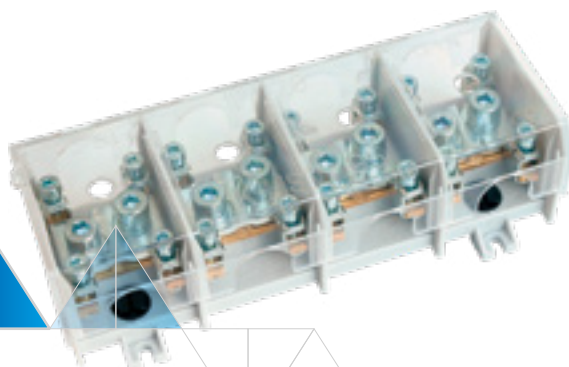
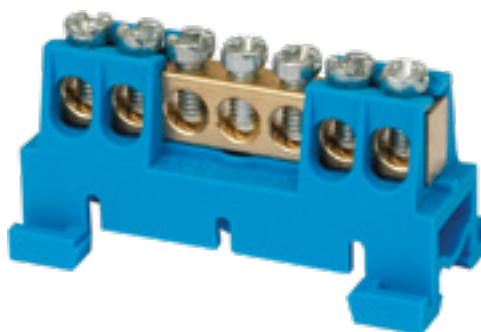
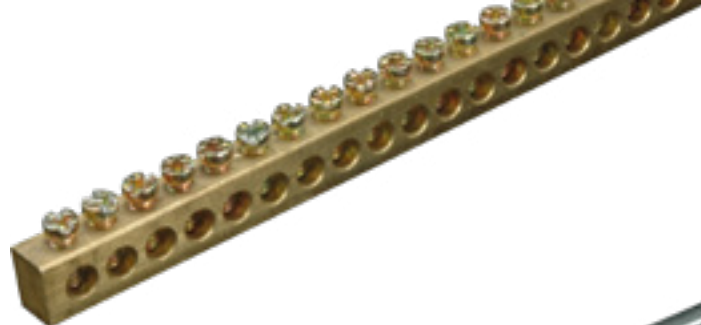

TERMINAL BLOCKS, STRIPS AND TERMINAL BOARDS

CONTENTS

Terminal blocks, strips and terminal boards	122 - 125
Terminal blocks	126 - 128
Ending clamp	128
DIN rails	129
Terminal strips	129
Instrument terminal strips	130
Ceramic couplings and ceramic terminal blocks	130 - 131
Terminal boards for rising mains	131 - 133
Equipotential terminal blocks	133



TERMINAL BLOCKS, STRIPS AND BOARDS

The basic features of the original system of terminal blocks by SEZ DK include:

RS, RSDPS are designed for connecting of copper rigid and stranded conductors. RSDPS are certified also for aluminum conductors

- quality plastic materials complying with the hot wire test for 850°C
- colour ranges adjusted to your requirements
- copper and brass materials with a special surface finish in order to provide the lowest transfer resistance and the maximum anti-corrosion protection
- high variability of connecting options

Technical solutions guarantee convenient, fast and effective installation of electric distributions. Terminal blocks are fitted with wound clamps with the screw shanks fastened in the pressed case. Unless otherwise stated, each terminal enables a reliable connection of one or more conductors with the nominal connecting cross section one or two degrees smaller (e.g. terminal 2,5 mm² enables the connection of conductors 1,5 or 1 mm² as well). The torsion moment of screw terminals complies with the requirements of EN 60998-2-1.

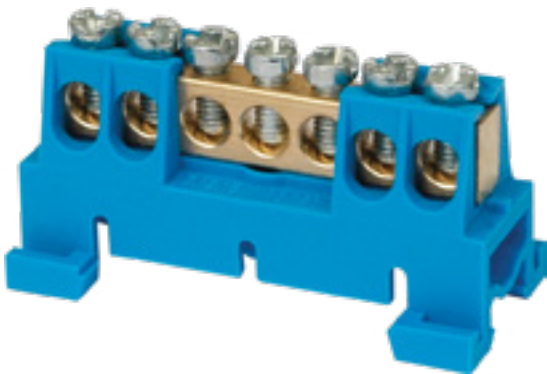

INTERCONNECTION OF TERMINAL BLOCKS

The interconnection of terminal blocks is enabled by jumpers for the connection of 2, 3 and 5 terminal blocks. The side walls of terminal blocks must be removed prior to connection. The jumpers consist of a connecting bridge and screws. After the connecting screws (screw) have been removed, the interconnection of terminal blocks over terminal blocks with a different voltage will also be enabled. The surface ways and air distances between jumpers and live parts of such terminal block correspond with the nominal insulation voltage. The interconnection range may be increased if several jumpers are connected by a connecting bridge for two terminal blocks.

TERMINAL BLOCKS RS

A terminal blocks for universal use.

It has the following advantages compared to RSDPS series:

- protection increased to IP 20
- when using jumpers, a space between terminal blocks is unnecessary
- better fastening to DIN rail
- larger connection range

TERMINAL BLOCKS RSDPS

Traditional and popular solution for electric distributions. Degree of protection IP 00. Both case and screws are made of brass.

JUMPERS

They are used for the permanent connection of adjoining terminal blocks in a terminal board. A space of the width of one terminal block must be left between the jumpers of different polarity and different poles, respectively.

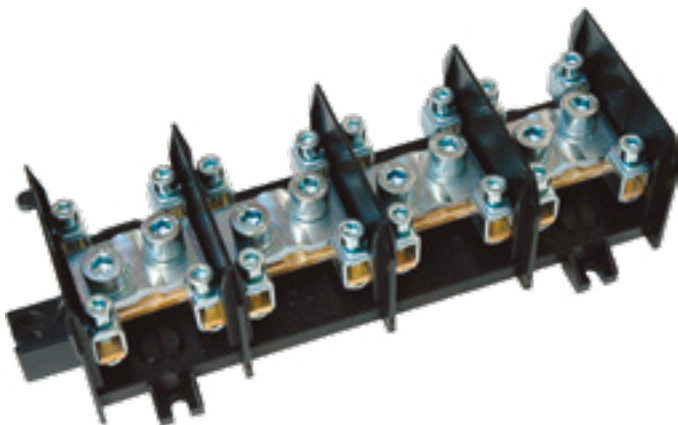

TERMINAL BOARDS FOR DEVICES AND RISING MAINS

Our terminal boards for devices and rising mains are manufactured from a variety of materials in order to ensure reliable operation under all conditions:

Material - thermoplast

- With permanent heat resistance 100 °C.
- For the operation environment -25 °C to 40 °C.
- With short-term heat resistance 140 °C.
 - With hot wire resistance 850 °C.

Ceramic material

- With permanent heat resistance 110 °C.
- With short-term heat resistance 140 °C.

Material for terminals

- Brass material.
- Brass material galvanically modified.

INSTRUMENT TERMINAL STRIPS 12 POLES

It is mainly used in industrial distributions in compliance with EN 60947-7-1. They are also designed for home use by EN 60998-2-1, which sets out the torque of screw terminals.

CERAMIC INSTRUMENT TERMINAL BLOCKS 4P/6P WITH FLANGE

Ceramic terminal blocks for devices are widely used in the connection of electric devices and in the distributors with a higher working temperature (up to 110 °C; up to 140 °C short-term).

Ceramic terminal blocks are manufactured in 4- and 6-pole modifications. Surface-treated terminal bridges made of brass are riveted on the body of terminal board. There are two fastening screw openings in the body.

TERMINAL BLOCKS FOR LIGHTING FITTINGS 2P/3P

Terminal blocks for lighting fittings have been designed for the connection in light distributions. Their ceramic case contains two (or three) bushing terminals in profile openings. The number of bushing terminals corresponds to the number of poles. There is one (or two) fastening opening(s) of $\varnothing 3,5$ mm in the case.

CERAMIC COUPLINGS FOR LIGHTING 1P/2P/3P

Ceramic couplings for lighting are used for the connection in electric light installations. The ceramic case contains 1-3 bushing terminals in profile openings. The number of bushing terminals corresponds to the number of poles.

TERMINAL BOARDS FOR RISING MAINS

They are used to connect branches to rising mains. All the Types consist of the main body made from thermoplastic which carries appropriate terminal H-bridges. Each bridge contains one transition splice clamp for the connection of main conductor without its interruption and 4 bushing terminals for connecting of branch conductors.

TERMINAL BOARDS 1P AND 4P FOR RISING MAINS 35 mm².

Terminal board 4P (Ord. No. 300510/HSV 35) is supplied in four-pole modification and terminal board 1P (Ord. No. 300480/SV 35) in single-pole modification. Terminal board 4P (Ord. No. 300510/HSV 35) and 1P (Ord. No. 300480/SV 35) may be joined to blocks to obtain a five-pole formation usable in a five-pole installation system. The construction of main board enables the fastening of terminal board to a pad by M5 screws or by sliding it on a shaped DIN rail TS 35 mm.

With cover:

Type 4P (Ord. No. 300511/HSV 35K) in fact an 4P (Ord. No. 300510/HSV 35) terminal board with a sealable cover made from transparent plastic, with openings for the measuring needle measurement, and with the degree of protection IP20 after of all the conductors have been connected into clamps. Type 1P (Ord. No. 300481/SVK 35) is in fact an 1P (Ord. No. 300480/SV 35) terminal board with a sealable cover made from transparent plastic, with openings for the measuring needle measurement, and with the degree of protection IP 20 after of all the conductors have been connected into clamps. Using 1P (Ord. No. 300480/SV 35) as a fifth pole, it is necessary to re-label sign "PEN" to "N" on 4P (Ord. No. 300510/HSV 35) and label the pole of 1P (Ord. No. 300480/SV 35) as "PE".

TERMINAL BOARDS 1P AND 4P FOR RISING MAINS 95 mm².

Terminal board 4P (Ord. No. 300520/HSV 95) is supplied in four-pole modification and terminal board 1P (Ord. No. 300490/SV 95) in single-pole modification. Terminal boards 4P (Ord. No. 300520/HSV 95) and 1P (Ord. No. 300490/SV 95) may be joined to blocks to obtain a five-pole formation usable in a five-pole installation system TN-S. The construction of main board enables the fastening of terminal board to a pad by M5 screws or by sliding it on a shaped DIN rail TS 35. The terminal board may be secured against drawing-out by a plastic bayonet joint.

With cover:

Type 4P (Ord. No. 300521/HSV 95K) is in fact an 4P (Ord. No. 300520/HSV 95) terminal board with a sealable cover made from transparent plastic, with openings for the measuring needle measurement, and with the degree of protection IP 20 after of all the conductors have been connected into clamps. Type 1P (Ord. No. 300491/SVK 95) is in fact an 1P (Ord. No. 300490/SV 95) terminal board with a sealable cover made from transparent plastic, with openings for the measuring needle measurement, and with the degree of protection IP 20 after of all conductors have been connected into clamps. Using 1P (Ord. No. 300490/SV 95) as a fifth pole, it is necessary to re-label sign "PEN" to "N" on 4P (Ord. No. 300520/HSV 95) and label the pole of 1P (Ord. No. 300490/SV 95) as "PE". Fastening with M5 screws or on DIN rail 35 mm.

EQUIPOTENTIAL TERMINAL BLOCKS SINGLE AND DOUBLE ROW

According to the norm STN 33 2000-4-41, the equalisation of potential is required during installation to provide safety against electric current injuries. It is achieved by the mutual connection of conductive non-live parts of the device and external conductive parts by a conductor of prescribed cross section.

The main connection is established in each building and in each object by a mutual conductive connection of the following elements:

- protection conductor of the network
- grounding supply or main protective terminal
- conductive pipeline and pipes leading into the object (gas, water, heating, air-conditioning, etc.)
- aerials, telephone devices.

The equipotential terminal board has been designed for main and also complementary connection in both home and industrial distributions. The connecting part of terminal board consists of brass bridge with steel terminals and splice for the fixation of main grounding or the steel rope. The terminals are mechanically secured against fall-out. The whole bridge is fixed in two insulation cases made from thermoplastic.

The terminal boards may be fastened in several ways:

- to rail Din TS 35
- by two screws of $\varnothing 5 \times 30$ through the bridge and the insulation case
- by four screws of $\varnothing 4 \times 10$ through the insulation case



Terminal blocks RS 2,5 - 120

- Designed for connecting of copper rigid and flexible conductors.
- Mutual interconnection of terminal blocks by using of jumpers for 2, 3 and 5 clamps.
- The surface ways and air distances between jumpers and live parts of such terminal block correspond with the nominal insulation voltage.
- Available in multiple colours.
- Mounting on DIN rails 35 mm: Ord. No. 300000 - 300041.
- Mounting on DIN rails 32 mm: Ord. No. 300028 - 300034.
- Mounting on DIN rails 15 mm: Ord. No. 300000 - 300027.

Complies with standards: EN 60947-7-1, EN 60998-2-1
 The torsion moment of screw terminals complies with the requirements: EN 60998-2-1
 Degree of protection: IP20
 Material: Polyamide PA6, Cu and brass
 Nominal insulation voltage: 800 V
 Glow wire test: 850 °C
 Operating temperature: -20 °C to +75 °C



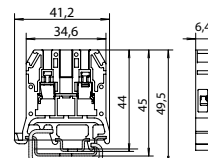
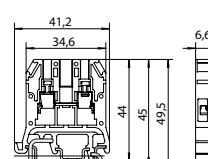
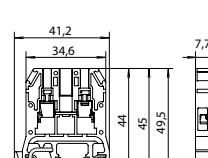
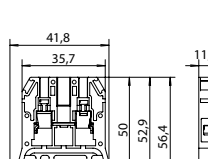
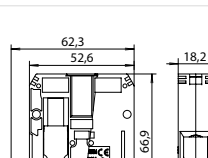
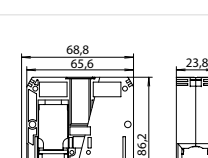

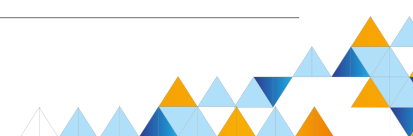

Ord. No. (Type)	Colour	Rigid conductor (mm ²)	Flexible conductor (mm ²)	Max. nominal current (A)	Stripped wire length (mm)	Pkg. (pcs.)	Dimensions (mm)
300000 (RS 2,5/0)	White ○	0,35 - 4	0,5 - 2,5	26		48	
300001 (RS 2,5/1)	Blue ●						
300002 (RS 2,5/2)	Gray ●						
300003 (RS 2,5/3)	Yellow ●						
300004 (RS 2,5/4)	Green ●						
300005 (RS 2,5/6)	Red ●						
300006 (RS 2,5/7)	Brown ●						
300007 (RS 6/0)	White ○	0,35 - 6	0,5 - 4	46	9	48	
300008 (RS 6/1)	Blue ●						
300009 (RS 6/2)	Gray ●						
300010 (RS 6/3)	Yellow ●						
300011 (RS 6/4)	Green ●						
300012 (RS 6/6)	Red ●						
300013 (RS 6/7)	Brown ●						
300014 (RS 10/0)	White ○	0,35 - 10	0,5 - 6	61	10.5	36	
300015 (RS 10/1)	Blue ●						
300016 (RS 10/2)	Gray ●						
300017 (RS 10/3)	Yellow ●						
300018 (RS 10/4)	Green ●						
300019 (RS 10/6)	Red ●						
300020 (RS 10/7)	Brown ●						
300021 (RS 25/0)	White ○	1,5 - 25	2,5 - 16	101	10	28	
300022 (RS 25/1)	Blue ●						
300023 (RS 25/2)	Gray ●						
300024 (RS 25/3)	Yellow ●						
300025 (RS 25/4)	Green ●						
300026 (RS 25/6)	Red ●						
300027 (RS 25/7)	Brown ●						
300028 (RS 50/0)	White ○	1,5 - 70*	2,5 - 50	150	14	18	
300029 (RS 50/1)	Blue ●						
300030 (RS 50/2)	Gray ●						
300031 (RS 50/3)	Yellow ●						
300032 (RS 50/4)	Green ●						
300033 (RS 50/6)	Red ●						
300034 (RS 50/7)	Brown ●						
300035 (RS 120/0)	White ○	2,5 - 120	6 - 95	269	20	7	
300036 (RS 120/1)	Blue ●						
300037 (RS 120/2)	Gray ●						
300038 (RS 120/3)	Yellow ●						
300039 (RS 120/4)	Green ●						
300040 (RS 120/6)	Red ●						
300041 (RS 120/7)	Brown ●						

* 95 mm² cross - section for rigid-stranded conductor

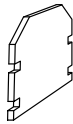

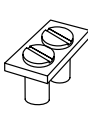
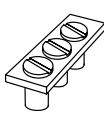
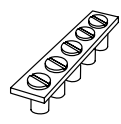
Accessories - terminal blocks

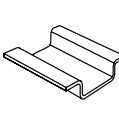
							
	Side plate	Ending clamp	Jumper for 2 term. blocks	Jumper for 3 term. blocks	Jumper for 5 term. blocks	Badge without description	DIN rail
RS term. blocks accs.			Ord. No. (Type)				
Ord. No. 300000 - 300006 (RS 2,5/x)	300100 (PRS/2)	300190 (RSD 88)	300110 (P 6/2)	300120 (P 6/3)	300130 (P 6/5)	300160 (Z5)	300200 (TS 35)
Ord. No. 300007 - 300013 (RS 6/x)			300111 (P 10/2)	300121 (P 10/3)	300131 (P 10/5)		
Ord. No. 300014 - 300020 (RS 10/x)	300101 (PRS/25/2)		300112 (P 25/2)	300122 (P 25/3)	300132 (P 25/5)		
Ord. No. 300021 - 300027 (RS 25/x)	-		300113 (P 50/2)	300123 (P 50/3)	-		
Ord. No. 300028 - 300034 (RS 50/x)	-		-	300124 (P 120/3)	-		
Ord. No. 300035 - 300041 (RS 120/x)	-		-	-	-		



Terminal blocks RSDPS

- Designed for connecting of copper rigid and flexible conductors - they are also certified for aluminum conductors.
- Mutual interconnection of terminal blocks by using of jumpers for 2, 3 clamps.
- The surface ways and air distances between jumpers and live parts of such terminal block correspond with the nominal insulation voltage.
- Mounting on DIN rail 35 mm, 32 mm, 15 mm.





Complies with standards:	EN 60947-7-1, EN 60998-2-1
The torsion moment of screw terminals complies with the requirements:	EN 60998-2-1
Degree of protection:	IP00
Material:	Polyamide PA6, Brass clamp and screws
Nominal insulation voltage:	500 V
Nominal insulation voltage:	660 V - Ord. No. 300082
Glow wire test:	850 °C
Operating temperature:	-20 °C to +75 °C

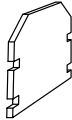

300080

Ord. No. (Type)	Colour	Rigid conductor (mm ²)	Flexible conductor (mm ²)	Max. nominal current (A)	Stripped wire length (mm)	Pkg. (pcs.)	Dimensions (mm)
300080 (RSDPS-00/7)	Brown ●	1.5	1.5	17.5	9	48	
300081 (RSDPS-10/7)		4	4	25	11	36	
300082 (RSDPS-20/7)	Brown ●	10	10	40	13	30	
300083 (RSDPS-30/7)		25	25	80	16	24	

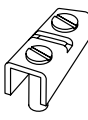
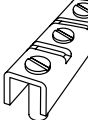
Types 300080 to 300083 - available while supplies last.

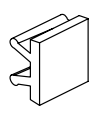
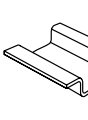
							
	Side plate	Ending clamp	Jumper for 2 term. blocks	Jumper for 3 term. blocks	Badge without description	Badge for RSDPS	DIN rail
RSDPS term. blocks accs.	Ord. No. (Type)						
Ord. No. 300080 (RSD-PS-00/7)	300102 (RSDPS-01)	300190 (RSD 88)	300140 (6035-03)	-	300160 (Z5)	300170 (6035-01 K)	300200 (TS 35)
Ord. No. 300081 (RSD-PS-10/7)	300103 (RSDPS-11)		300141 (6035-13)	300150 (6035-12)			
Ord. No. 300082 (RSD-PS-20/7)	300104 (RSDPS-21)		300142 (6035-23)	300151 (6035-22)			
Ord. No. 300083 (RSD-PS-30/7)	300105 (RSDPS-31)		300143 (6035-33)	300152 (6035-32)			

Ending clamp

- It is used to secure a group of terminal blocks on a DIN rail against side displacement.

Material:	Polyamide
Operating temperature:	-20 °C to +75 °C



300190

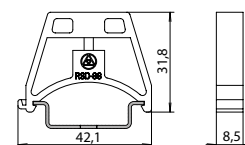

Ord. No. (Type)	Width (mm)	Pkg. (pcs.)
300190 (RSD 88)	8,5	200

Din rails TS 35

- Designed for mounting devices (MCBs, contactors, terminals, etc.) in switchboards or distribution boxes.
- With holes and grooves at both ends for quick mounting on the base.
- Width 35 mm.

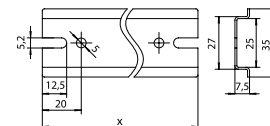

Material: Zinc steel

300200

Ord. No. (Type)	Length (x) (mm)	Pkg. (pcs.)
300200 (TS 35/10/0)	100	20
300201 (TS 35/160/2)	160	
300202 (TS 35/20/0)	200	
300203 (TS 35/210/2)	210	
300204 (TS 35/250/2)	250	
300205 (TS 35/30/0)	300	
300206 (TS 35/40/0)	400	
300207 (TS 35/50/0)	500	
300208 (TS 35/60/0)	600	
300209 (TS 35/70/0)	700	
300210 (TS 35/80/0)	800	
300211 (TS 35/90/0)	900	
300212 (TS 35/100/0)	1000	
300213 (TS 35/110/0)	1110	
300214 (TS 35/120/0)	1200	

Perforated DIN rails TSP

- Designed for mounting devices (MCBs, contactors, terminals, etc.) in switchboards or distribution boxes.
- With holes and grooves at both ends for quick mounting on the base.
- Width 35 mm.

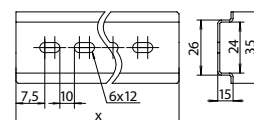
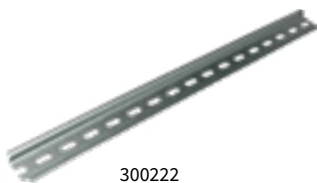

Material: Zinc steel

300222

Ord. No. (Type)	Length(x) (mm)	Height (mm)	Pkg. (pcs.)
300222 (TSP 35-SZP 35H7/1)	1000	7	50
300229 (TSP 35-SZP35H7/2)	2000		30
300232 (TSP 35-SZP35H15/1)	1000	15	10
300239 (TSP 35-SZP35H15/2)	2000		20

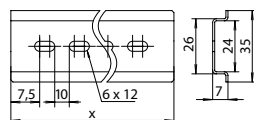

300232, 300239

300222, 300229

Terminal strips 7/12/15 clamps

- Terminal blocks for mounting on a 35 mm DIN rail width.
- DIN rail mounting by clicking.
- Available in green, blue, black and yellow.

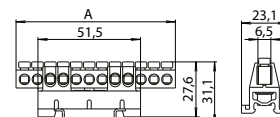

Complies with standards: EN 60947-7-1, EN 60998-2-1
Degree of protection: IP00
Material: Polyamide PA6 - self-extinguishing
Material: Brass
Screws: M4
Operating temperature: -5 °C to +60 °C

300251

Ord. No. (Type)	Colour	Number of clamps	Voltage (V)	Current (A)	Max. Cu conductor cross section		A (mm)	Pkg. (pcs.)
					Rigid (mm ²)	Flexible (mm ²)		
300250 (7/Z)	Green	7	660	63	16	10	47	45
300251 (7/N)	Blue							
300252 (7/C)	Black							
300253 (7/Y)	Yellow	12	660	63	16	10	80	25
300254 (12/Z)	Green							
300255 (12/N)	Blue							
300256 (12/C)	Black	15	660	63	16	10	99	25
300257 (12/Y)	Yellow							
300258 (15/Z)	Green							
300259 (15/N)	Blue	15	660	63	16	10	99	25
300260 (15/C)	Black							
300261 (15/Y)	Yellow							

Screw brass bar

- For Cu rigid conductor up to 16 mm², for Cu flexible conductor up to 10 mm²
- Use in switchboards.

Material:	Brass
Degree of protection:	IP00
Screws:	M4

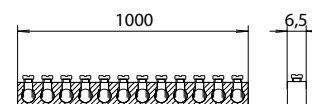
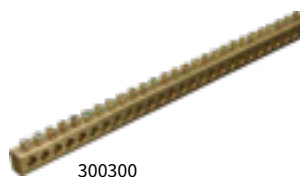

Ord. No. (Type)	Length (mm)	Rigid conductor (mm ²)	Flexible conductor (mm ²)	Pkg. (pcs.)
300300 (NS 154/100)	1000	16	10	1

Instrument terminal strips 12 poles

- Connecting of two conductors by two screws in a brass profile clamp.
- The required number of clamps can be separated with by a knife or breaking up.

Complies with standards:	EN 60947-1, EN 60947-7-1 EN 60998-1, EN 60998-2-1 EN 60999
Degree of protection:	IP20
Material:	Thermoplastic, Brass

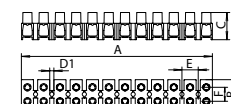
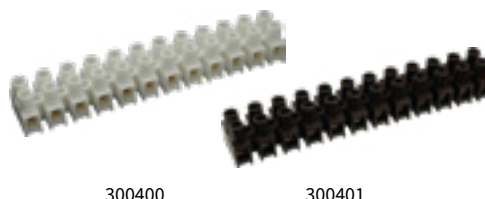

Ord. No. (Type)	Colour	Cross section (mm ²)	Voltage (V)	Current (A)	Number of poles	Pkg. (pcs.)	Dimensions (mm)						
							A	B	C	D1	E	F	
300400 (6336-10)	White ○	1,5	400	17,5	12	35	94,6	16	13,7	2,6	8,1	6,4	
300401 (6336-17)	Brown ●												
300402 (6336-20)	White ○	2,5		24			30	116,6	19	17,2	3,2	10	8
300403 (6336-27)	Brown ●												
300404 (6336-30)	White ○	4		32			40	134,5	23	19	3,3	11,5	10
300405 (6336-37)	Brown ●												
300406 (6336-50)	White ○	6		41	40	134,5	21	18,7	3,3	11,5	10		
300407 (6336-57)	Brown ●												
300408 (6336-60)	White ○	10		57	40	150,3	23	21,4	3,3	12,8	11		
300409 (6336-67)	Brown ●												
300410 (6336-70)	White ○	16		76	15	150,3	23	21,4	3,3	12,8	11		
300411 (6336-77)	Brown ●												

Ceramic couplings for lighting 1P/2P/3P

- For connection in electric lighting fixtures and heating elements.

Complies with standards:	STN 60998-2-1, EN 60947-7-1
Degree of protection:	IP20
Material:	Ceramics, brass clamps
Permanent heat resistance:	+110 °C

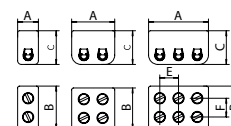

Ord. No. (Type)	Cross section (mm ²)	Voltage (V)	Current (A)	Number of poles	Pkg. (pcs.)	Dimensions (mm)				
						A	B	C	E	F
300430 (6110 -06)	4	400	-	1	275	11	23	18	-	10
300431 (6111-06)				2	135	22			10	
300432 (6112-06)				3	90	33			10	

Ceramic terminal blocks for lighting fittings 2P/3P

- For fire resistant boxes.
- For connection in a lighting system.
- Types 300442, 300443 are suitable for applications requiring proven functionality in fire.

Complies with standards:	EN 60947-7-1
Degree of protection:	IP00
Material:	Ceramics
Permanent heat resistance:	+110 °C

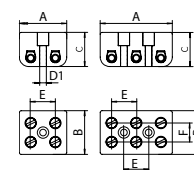

Ord. No. (Type)	Cross section (mm ²)	Voltage (V)	Current (A)	Number of poles	Pkg. (pcs.)	Dimensions (mm)					
						A	B	C	D1	E	F
300440 (6311 - 06)	4	400	-	2	120	25	23	18	3,5	13	10
300441 (6311 - 07)				3	83	38					
300442 (6311 - 04)	10	400	-	2	120	25	23	18	3,5	13	10
300443 (6311 - 05)				3	83	38					

Ceramic instrument terminal blocks 4P/6P with flange

- Using for connection of electric devices and appliances with a higher working temperature.

Complies with standards: EN 60947-7-1
Degree of protection: IP00
Material: Ceramics, Brass
Permanent heat resistance: +110 °C



300460

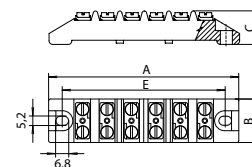

Ord. No. (Type)	Cross section (mm ²)	Voltage (V)	Current (A)	Number of poles	Pkg. (pcs.)	Dimensions (mm)			
						A	B	C	E
300460 (6313 -14 MP)	4	400	20	4	36	77	24	18	64
300461 (6314-14 MP)				6	24	104			90

Ceramic instrument terminal blocks 4P/6P

- Surface-treated brass terminal bridges.

Complies with standards: EN 60947-7-1
Degree of protection: IP00
Material: Ceramics, Brass
Permanent heat resistance: +110 °C



300470

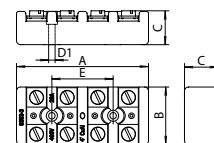

Ord. No. (Type)	Cross section (mm ²)	Voltage (V)	Current (A)	Number of poles	Pkg. (pcs.)	Dimensions (mm)				
						A	B	C	E	D1
300470 (6353 -30)	4	400	20	4	75	65,5	28,5	17	30,4	3,2
300471 (6354-30)				6	28	95,9			60,8	

Terminal boards 1P for rising mains 35 mm²

- They are used in rising distribution boards in apartment buildings.
- No need to interrupt the main rising conductor.
- Ord. No. 300481 - with cover.
- Fastening with M5 screws or on DIN rail 35 mm.
- The lock allows terminal blocks to be connected side by side.
- Rising terminals boards sealable.
- Inbus screws with cylinder head.

Complies with standards: EN 60947-7-1, EN 60998-2-1
Degree of protection: IP00, IP20 with cover
Material: Thermoplastic



300480



300481

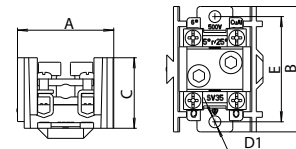

Ord. No. (Type)	Connec. cross section (mm ²)		Clamps for main conductor	Clamps for secondary conductor	Nominal insulation. voltage (V)	Nominal current of conductor (A) Main/Secondary	Number of poles	Pkg. (pcs.)	Dimensions (mm)				
	Main. conductor Cu, Al	Side conductor Cu, Al							A	B	C	D1	E
300480 (SV 35)	10 - 35	2,5 - 6/10r Cu	1	4	500	125 / 41	1	32	42	56	31	5,4	47
300481 (SVK 35)								30	60	33,5			

Terminal boards 1P for rising mains 95 mm²

- They are used in rising distribution boards in apartment buildings.
- No need to interrupt the main rising conductor.
- Ord. No. 300491 - with cover.
- Fastening with M5 screws or on DIN rail 35 mm.
- The lock allows terminal blocks to be connected side by side.
- Rising terminals boards sealable.
- Inbus screws with cylinder head.

Complies with standards: EN 60947-7-1, EN 60998-2-1
Degree of protection: IP00, IP20 with cover
Material: Thermoplastic



300490



300491

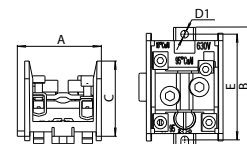

Ord. No. (Type)	Connec. cross section (mm ²)		Clamps for main conductor	Clamps for secondary conductor	Nominal insulation. voltage (V)	Nominal current of conductor (A) Main/Secondary	Number of poles	Pkg. (pcs.)	Dimensions (mm)				
	Main. conductor Cu, Al	Side conductor Cu, Al							A	B	C	D1	E
300490 (SV 95)	16 - 95	6 - 16/25r Cu	1	4	630	232 / 76	1	36	57	81	51	5,4	72
300491 (SVK 95)									53				

Terminal boards 4P for rising mains 35 mm²

- They are used in rising distribution boards in apartment buildings.
- No need to interrupt the main rising conductor.
- Ord. No. 300511 - with cover.
- Fastening with M5 screws or on DIN rail 35 mm.
- The lock allows terminal blocks to be connected side by side.
- Rising terminals boards sealable.
- Inbus screws with cylinder head.

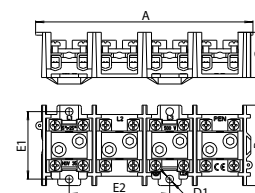

Complies with standards: EN 60947-7-1, EN 60998-2-1
Degree of protection: IP00, IP20 with cover
Material: PA6

300510

Ord. No. (Type)	Connec. cross section (mm ²)		Clamps for main conductor	Clamps for secondary conductor	Nominal insulation voltage (V)	Nominal current of conductor (A) Main/Secondary	Number of poles	Pkg. (pcs.)	Dimensions (mm)					
	Main. conductor Cu, Al	Side conductor Cu, Al							A	B	C	D1	E1	E2
300510 (HSV 35)	10 - 35	2,5 - 6/10r Cu	4	16	500	125 / 41	4	8	148	56	31	5,4	47	70
300511 (HSV 35 K)										64	33,5			

Terminal boards 4P for rising mains 95 mm²

- They are used in rising distribution boards in apartment buildings.
- No need to interrupt the main rising conductor.
- Ord. No. 300521 - with cover.
- Fastening with M5 screws or on DIN rail 35 mm.
- The lock allows terminal blocks to be connected side by side.
- Rising terminals boards sealable.
- Inbus screws with cylinder head.

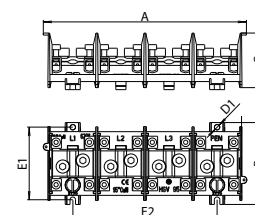

Complies with standards: EN 60947-7-1, EN 60998-2-1
Degree of protection: IP00, IP20 with cover
Material: PA6

300521

Ord. No. (Type)	Con. cross section (mm ²)		Clamps for main conductor	Clamps for secondary conductor	Nominal insulation voltage (V)	Nominal current of conductor (A) Main/Secondary	Number of poles	Pkg. (pcs.)	Dimensions (mm)					
	Main. conductor Cu, Al	Side conductor Cu, Al							A	B	C	D1	E1	E2
300520 (HSV 95)	16 - 95	6 - 16/25r Cu	4	16	630	232 / 76	4	9	201	81	51	5,4	72	143
300521 (HSV 95 K)											53			

Terminal boards 4P for rising mains 95 mm² - black

- They are used in rising distribution boards in apartment buildings.
- No need to interrupt the main rising conductor.
- Ord. No. 300531 - with cover.
- Fastening with M5 screws or on DIN rail 35 mm.
- Rising terminals boards sealable.
- Inbus screws with cylinder head.

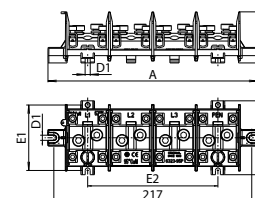

Complies with standards: EN 60947-7-1, EN 60998-2-1
Degree of protection: IP00, IP20 with cover
Material: PA6

300530

Ord. No. (Type)	Con. cross section (mm ²)		Clamps for main conductor	Clamps for secondary conductor	Nominal insulation voltage (V)	Nominal current of conductor (A) Main/Secondary	Number of poles	Pkg. (pcs.)	Dimensions (mm)					
	Main. conductor Cu, Al	Side conductor Cu, Al							A	B	C	D1	E1	E2
300530 (6323 - 95 P)	16 - 95	6 - 16/25r Cu	4	16	630	232 / 76	4	8	230	81	56	5,4	72	143
300531 (6323 - 95 PK)											58			

Covers for rising terminal boards 1P

- Transparent covers can be secured by sealing.

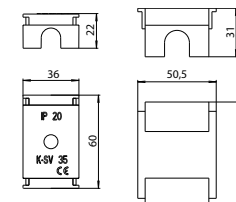
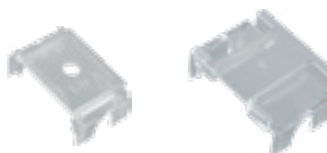

Material: Transparent polycarbonate

300540

300541

Ord. No. (Type)	Use with terminal blocks (Ord. No.)	Pkg. (pcs.)
300540 (ND SV 35)	300480	24
300541 (ND SV 95)	300490	36



Covers for rising terminal boards 4P

• Transparent covers can be secured by sealing.

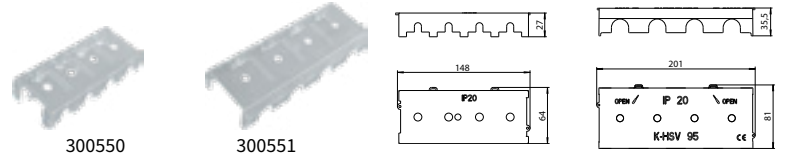

Material: Transparent polycarbonate

Ord. No. (Type)	Transparent polycarbonate (Ord. No.)	Pkg. (pcs.)
300550 (ND HSV 35)	300510	40
300551 (ND HSV 95)	300520 300530	10

Equipotential terminal blocks double row

- Version with cover designed for a wall installation or on DIN rail with the possibility of sealing.
- Version without cover designed for an in-box installation or on DIN rail in switchboard.
- Ord. No. 300601 - with cover.

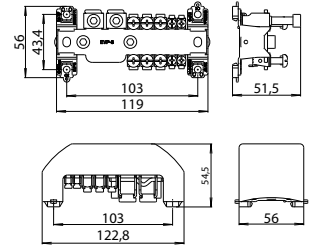

Complies with standards: EN 60947-7-1, EN 60998-2-1, EN 60998-1
Degree of protection: IP00, IP20 with cover
Material: Brass bridge with steel screw clamps, isolators PA6.

Ord. No. (Type)	Connectable cross section (mm ²)	Connectable grounding belt	Number of clamps for conductors	Pkg. (pcs.)
300600 (EVP-S)	2,5 - 10	30 x 4 mm or 20 x 3 mm ø 8 - 12 mm*	4	6
	10 - 25		6	
	25 - 70		2	
300601 (EVP-SK with cover)	2,5 - 10	30 x 4 mm or 20 x 3 mm ø 8 - 12 mm*	4	4
	10 - 25		6	
	25 - 70		2	

* if necessary, this terminal for the groundig belt can also be used to connect a round conductor

Equipotential terminal blocks single row

- Version with cover designed for a wall installation or on DIN rail with the possibility of sealing.
- Version without cover designed for an in-box installation or on DIN rail in switchboard.
- Ord. No. 300611 - with cover.

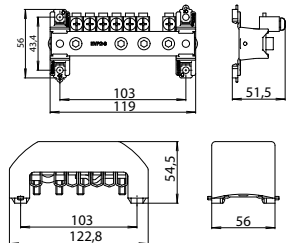
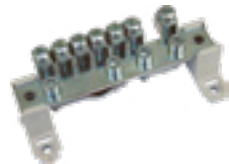

Complies with standards: EN 60947-7-1, EN 60998-2-1, EN 60998-1
Degree of protection: IP00, IP20 with cover
Material: Brass bridge with steel screw clamps, isolators PA6.

Ord. No. (Type)	Connectable cross section (mm ²)	Connectable grounding belt	Number of clamps for conductors	Pkg. (pcs.)
300610 (EVP2-S)	8 - 10	30 x 4 mm or 20 x 3 mm ø 8-12 mm*	1	7
	10 - 25		7	
300611 (EVP2-SK with cover)	8 - 10	30 x 4 mm or 20 x 3 mm ø 8-12 mm*	1	4
	10 - 25		7	

* if necessary, this terminal for the groundig belt can also be used to connect a round conductor

Cover equipotential terminal block

- Cover can be secured by sealing for Ord. No: 300600 and 300610.
- The cover common for single and double-row terminal blocks.

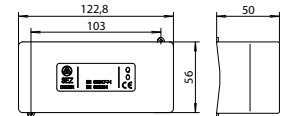

Material: PA6

Ord. No. (Type)	Use with terminal blocks (Ord. No.)	Pkg. (pcs.)
300620 (EVP-K)	300600	6
	300610	



INSTALLATION BOXES, CABLE GLANDS AND TERMINAL BLOCKS

CONTENTS

Installation boxes, cable glands and terminal blocks	136- 139
On wall boxes with terminal rings	140 - 141
Under the plaster boxes	141 - 142
Hollow walls boxes	143 - 144
Hollow walls boxes, terminal rings	144
On wall boxes	145 - 146
Junction box with proven functionality in fire	147
Surface boxes for trunkings	148
On wall boxes IP65	149
Junction and lightning protection boxes	150
Cable glands Pg, Metric and fixing nuts	151 - 153
Cable connectors	154
Mounting accessories	155 - 157



Installation boxes, cable glands and terminal blocks

The safety of electric installations is greatly influenced by the quality of the installation distributions used in residential and industrial buildings. While most cable distributions are protected by the self-extinguishing halogen PVC, installation boxes available on the market are manufactured from various plastics with different self-extinguishability rates.

INSTALLATION ON FLAMMABLE SURFACES

SEZ DK realizes our responsibility for your safety and so we developed an elaborated informational system of the usability of our installation boxes on the different classes of building materials with respect to their flammability. Standard STN EN 13501-1 introduced a new approach, where instead of flammability introduced "Reaction to fire".

tab. 1 - Slovak Republic

Degree of flammability according to the old STN 73 0862		Classification according to the new STN EN 13501-1 (Reaction to fire)
A	Non-flammable	A1
		A2-s1, d0
B	Not easily flammable	Other A2, B
C1	Difficulty flammable	C
C2	Medium flammable	D, E
C3	Easily flammable	F

tab. 2 - Czech Republic

Degree of flammability according to the old CSN 73 0862		Classification according to the new STN EN 13501-1 (Reaction to fire)
A	Non-flammable	A1
B	Not easily flammable	A2
C1	Difficulty flammable	B
C2	Medium flammable	C or D
C3	Easily flammable	E or F

Below we present a detailed classification of particular building materials according to their trade names.

LISTING OF BUILDING MATERIALS IN TERMS OF THEIR FLAMMABILITY ACCORDING TO STN 730823

Class: A - Meaning: non-flammable building materials

Example: stone, slate, sandstone, granite, concrete, bricks, concrete blocks, pavement blocks, ceramic tiles, mortars, cement plasters, gypsum plasters, perlite, building metals (steel, aluminum), glass, fused basalt and fire-retardant coatings and some types of plasterboard.

Class: B - Meaning: not easily flammable

Example: Akumin, Izomin, Heraclite, nonsoftened PVC (Novodur, Durofol B), tough PVC (Duroplast H, Dekorplast), retarded polyester glass laminate, mineral fiber boards (basalt felt).

Class: C1 - Meaning: difficulty flammable

Example: foliaceous wood (oak, beech, ash), retarded polystyrene, hardened paper, organic fiber boards, plywood for general use.

Class: C2 - Meaning: medium flammable

Example: coniferous wood (spruce, fir, pine, red spruce), general purpose chipboard, SP-type cork boards, cork parquets, rubber flooring.

Class: C3 - Meaning: easily flammable

Example: laminated chipboards, sawdust boards, BA type cork boards, linear polyethylene, expanded polyethylene standard, organic glass (Acrylon, Umplex), polypropylene, foam rubber, rubber insulation carpet for electrical engineering, floor fabrics woven with synthetic fibres, cardboard and bituminous binder materials, asphalt belt with a type S cardboard insert.

According to the new standard STN 332312: 2013 not required thermal insulation panel. Article 4. 6. 1 of that standard states that the mounting box directly into a flammable material can be performed, provided that the boxes are resistant to the spread of flame, or meet resistance of insulating material requirements according to STN EN 60670 -1 i resistance to glow wire 650 °C. (850 °C for hollow walls).

MATERIALS USED

We build on our long-standing experience and our customers' requirements in the construction of our products. We take into account the requirements of maximum quality and environmental protection, as well as those of budget limitations.

RESISTANCE OF MATERIALS

The external parts of products and the insulation parts bearing live parts must be resistant to both excessive heat and combustion. The hot wire test, detailed in IEC 60695-2-11, is used to check whether this requirement has been met. The minimum resistance to hot wire effects is 650 °C for covers made of insulation material and 850 °C for insulation parts bearing live parts and for insulation parts into hollow walls.



Junction boxes ACIDUR 3 with Pg lamellar cable glands - IP67

- Used for connecting and branching of installation cables.
- For use in an environment with increased humidity and dust.
- Cable sealing with a single elastic sealing ring.
- Ensured sealing after cutting off the preinjected blanks even without a cable.
- Protected design at EU level.

Complies with standards: STN EN 60670-1 and STN EN 60670-22
 Degree of protection: IP67
 Material: PA - self-extinguishing 30 s
 Nominal insulation voltage: 400 V~
 Glow wire test: 850 °C
 Installation on the surface of class (SK): I_{max} ≤ 16 A - materials A1 to E
 I_{max} > 16 A - material A1
 Operating temperature: -25 °C to +60 °C



Ord. No. (Type)	Rigid conductor cross section (mm ²)	Bridges / No. of terminals			Sealing range (mm)	Colour	Pkg. (pcs.)	Dimensions (mm)			
		L	N	PE				A	B	d	C
400022 (6455-11 5.P/2 ACIDUR 3)	4	3/4	1/4	1/4	7 - 14,5	grey	50	125	106	4,2	45
400023 (6455-11 5.P/5 ACIDUR 3)						black					
400024 (6455-11 5.P/7 ACIDUR 3)						brown					
400025 (6455-12 5.P/2 ACIDUR 3)						grey					
400026 (6455-12 5.P/5 ACIDUR 3)	4	3/4	1/4	-	7 - 14,5	black	50	125	106	4,2	45
400027 (6455-12 5.P/7 ACIDUR 3)						brown					

Junction boxes ACIDUR Classic with Pg cable glands - IP67

- Used for connecting and branching of installation cables.
- For use in an environment with increased humidity and dust.
- Cable glands with two cut-off thin-wall elastic rings to achieve appropriate sealing in two ranges.

Complies with standards: STN EN 60670-1 and STN EN 60670-22
 Degree of protection: IP67
 Material: PP - self-extinguishing 30 s
 Nominal insulation voltage: 400 V~
 Glow wire test: 850 °C
 Installation on the surface of class (SK): I_{max} ≤ 16 A - materials A1 to E
 I_{max} > 16 A - material A1
 Operating temperature: -25 °C to +60 °C



Ord. No. (Type)	Rigid conductor cross section (mm ²)	Bridges / No. of terminals			Sealing range (mm)	Colour	Pkg. (pcs.)	Dimensions (mm)			
		L	N	PE				A	B	d	C
400010 (6455-11P/2)	4	3/4	1/4	1/4	8 - 12 12 - 16	grey	50	122	105	4,2	44,6
400011 (6455-11P/5)						black					
400012 (6455-11P/7)						brown					
400013 (6455-11P/2/BM)	4	3/4	1/4	-	8 - 12 12 - 16	grey	50	122	105	4,2	44,6
400014 (6455-12P/2)						black					
400015 (6455-12P/5)						brown					
400016 (6455-12P/7)	6	3/4	1/4	-	9 - 13 15 - 19	grey	20	144	134	5,3	67,0
400017 (6455-26P/2)						black					
400018 (6455-26P/5)						brown					
400019 (6455-26P/2E)	6	3/4	1/4	1/4	9 - 13 15 - 19	grey	20	144	134	5,3	67,0
400020 (6455-27P/2)						black					
400021 (6455-27P/5)						black					

Junction boxes with snap-on lid and elastic cut-off glands - IP54

- Used for connecting and branching of installation cables.
- Snap-on lid reduces box opening time by 90 %.
- Version with screw terminals or without (empty box).
- Elastic cut-off gland 4 x Pg 13,5.

Complies with standards: STN EN 60670-1 and STN EN 60670-22
 Degree of protection: IP54
 Material: PP - self-extinguishing 30 s
 Nominal insulation voltage: 400 V~
 Glow wire test: 850 °C
 Installation on the surface of class (SK): I_{max} ≤ 16 A - materials A1 to E
 I_{max} > 16 A - material A1
 Operating temperature: -25 °C to +60 °C

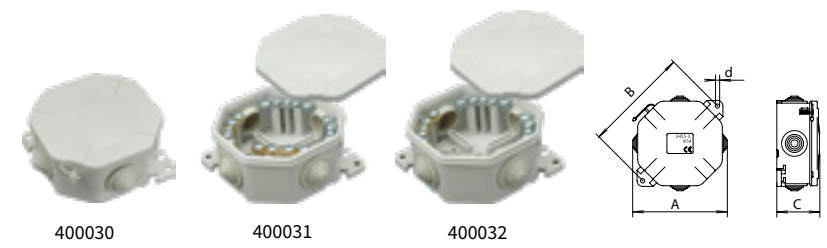

Ord. No. (Type)	Rigid conductor cross section (mm ²)	Bridges / No. of terminals			Sealing range (mm)	Colour	Pkg. (pcs.)	Dimensions (mm)			
		L	N	PE				A	B	d	C
400030 (6455-30)	-	-	-	-	4 - 17	grey	60	94	105	4,2	42,9
400031 (6455-31)	4	3/4	1/4	1/4							
400032 (6455-32)	4	3/4	1/4	-							



Junction box with elastic cut-off glands - IP43

- Used for connecting and branching of installation cables.
- Cable sealing range from 7 to 14 mm.
- The box contains 4P terminal ring.

Complies with standards:	STN EN 60670-1 and STN EN 60670-22
Degree of protection:	IP43
Material:	PVC - self-extinguishing 30 s
Nominal insulation voltage:	400 V~
Glow wire test:	850 °C
Installation on the surface of class (SK):	Imax ≤ 16 A - materials A1 to E
Operating temperature:	Imax > 16 A - material A1 -25 °C to +60 °C



400040

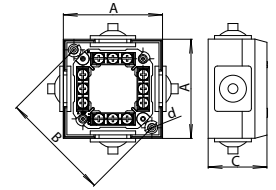

Ord. No. (Type)	Rigid conductor cross section (mm ²)	Bridges / No. of term.		Sealing range (mm)	Colour	Pkg. (pcs.)	Dimensions (mm)			
		L	N				A	B	d	C
400040 (6456-13)	4	3/3	1/3	7 - 14	white	90	70	77,8	3,2	41,5

Universal boxes 71 x 43 mm

- Allows to install the lid by snapping at the adjustable depth.
- Allows to install also a lid with a 60 mm screw distance.
- The lock allows to link boxes side by side.

Complies with standards:	STN EN 60670-1 and STN EN 60670-22
Degree of protection:	IP20 with lid
Material:	PP
Nominal insulation voltage:	400 V~
Glow wire test:	650 °C
Installation on the surface of class (SK):	material A1
Operating temperature:	-25 °C to +60 °C



400100



400101



400102

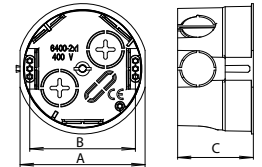

Ord. No. (Type)	Diameter (mm)	Depth (mm)	Inlet openings	Accessories in the package	Colour	Pkg. (pcs.)	Dimensions (mm)		
							A	B	C
400100 (6400-201/3)	71	43	7 x ø 20 1 x (6 x 20)	-	black	140	71	60	43
400101 (6400-211/3)		43		Lid 82 mm		70			
400102 (6400-221/3)		43		Lid 82 mm 4P/3 terminal ring		70			

Univerzal deep box 71 x 73 mm for intelligent installations

- Used for simultaneous cables distribution and installation of terminal ring 4P/3 clamps and installation of electro-installation devices as well as devices of intelligent installation.
- Allows to install also a lid with a 60 mm screw distance.
- The lock allows to link boxes side by side.

Complies with standards:	STN EN 60670-1 and STN EN 60670-22
Degree of protection:	IP20 with lid
Material:	PP
Nominal insulation voltage:	400 V~
Glow wire test:	650 °C
Installation on the surface of class (SK):	material A1
Operating temperature:	-25 °C to +60 °C



400110

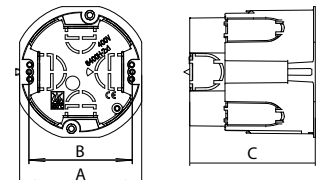

Ord. No. (Type)	Diameter (mm)	Depth (mm)	Inlet openings	Accessories in the package	Colour	Pkg. (pcs.)	Dimensions (mm)		
							A	B	C
400110 (6400 H-201/3)	71	73	4 x (21 x 33) 2 x (21 x 23) 2 x (17 x 21)	-	grey	54	71	60	73

Universal box 112 x 52 mm

- Used for convenient branching of cables (generous mounting space).
- Allows you to install terminal rings 4P/4 clamps or 5P/4 clamps.

Complies with standards:	STN EN 60670-1 and STN EN 60670-22
Degree of protection:	IP20 with lid
Material:	PP
Nominal insulation voltage:	400 V~
Glow wire test:	650 °C
Installation on the surface of class (SK):	material A1
Operating temperature:	-25 °C to +60 °C



400120

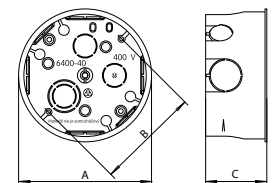

Ord. No. (Type)	Diameter (mm)	Depth (mm)	Inlet openings	Accessories in the package	Colour	Pkg. (pcs.)	Dimensions (mm)		
							A	B	C
400120 (6400 -41)	71	73	4 x ø 20 4 x ø 27 1 x ø 20/27	Lid 120 mm	black	32	112	88	52

Instrument box 71 x 43 mm halogen-free

- Halogen-free material for buildings with an increased request for protection of people and property.
- The lock allows to link boxes side by side.

Complies with standards:	STN EN 60670-1
Degree of protection:	IP20 with lid
Material:	ABS - halogen-free
Nominal insulation voltage:	400 V~
Glow wire test:	650 °C
Installation on the surface of class (SK):	material A1
Operating temperature:	-25 °C to +60 °C



400130

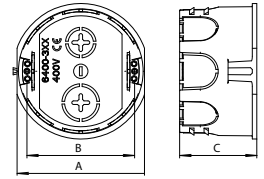

Ord. No. (Type)	Diameter (mm)	Depth (mm)	Inlet openings	Accessories in the package	Colour	Pkg. (pcs.)	Dimensions (mm)		
							A	B	C
400130 (6400 -301)	71	43	8 x (20 x 20) 1 x ø 17 1 x ø 21	-	black	140	71	60	43

Instrument box 71 x 32 mm for thin walls

- Used for mounting of electrical installation devices in thin walls.
- The lock allows to link boxes side by side.

Complies with standards:	STN EN 60670-1
Degree of protection:	IP20 with lid
Material:	PP
Nominal insulation voltage:	400 V~
Glow wire test:	650 °C
Installation on the surface of class (SK):	material A1
Operating temperature:	-25 °C to +60 °C



400140

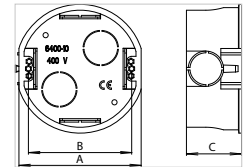

Ord. No. (Type)	Diameter (mm)	Depth (mm)	Inlet openings	Accessories in the package	Colour	Pkg. (pcs.)	Dimensions (mm)		
							A	B	C
400140 (6400 -10)	71	32	6 x ø 20	-	black	100	71	60	32

Lids with screws

- For final covering of universal and instrument junction boxes.
- Lid used for closing of boxes with a 60 mm screw distance.

Complies with standards:	STN EN 60670-1
Material:	ABS
Glow wire test:	650 °C
Operating temperature:	-25 °C to +60 °C



400150

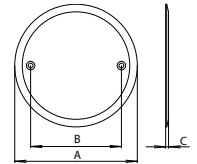

Ord. No. (Type)	Diameter (mm)	Depth (mm)	Colour	Pkg. (pcs.)	Dimensions (mm)		
					A	B	C
400150 (V 081)	81	1,9	white	100	81	60	1,9

Snap-on lids

- For final covering of universal and instrument junction boxes.
- The lengthened thread of lid is used when mounted into a box which has not been levelled with the plaster surface. Break off the lengthened part of thread when mounting into a correctly installed box.

Complies with standards:	STN EN 60670-1
Material:	ABS
Glow wire test:	650 °C
Operating temperature:	-25 °C to +60 °C



400151

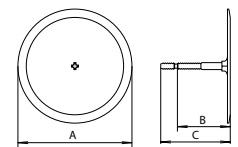
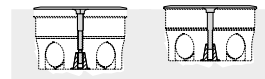

Ord. No. (Type)	Diameter (mm)	Depth (mm)	Colour	Pkg. (pcs.)	Dimensions (mm)		
					A	B	C
400151 (V 082)	82	50	white	300	82	38	50
400152 (V 120)	120	60		220	120	48	60



Deep univerzal box 71 x 73 mm for intelligent installations

- Used for simultaneous cables distribution and installation of terminal ring 4P/3 clamps and installation of electro-installation devices as well as devices of intelligent installation.
- Thickness of the hollow wall 10 to 30 mm.
- The lock allows to link boxes side by side.
- Box designed for use in hollow walls.
- Ord. No. 400201 includes a terminal ring 4P/3 with a 82 mm lid.

Complies with standards: STN EN 60670-1 and STN EN 60670-22
Material: PP - self-extinguishing 30 s
Nominal insulation voltage: 400 V~
Glow wire test: 850 °C
Instal. on the surface of class (SK): materials A1 to E
Operating temperature: -25 °C to +60 °C

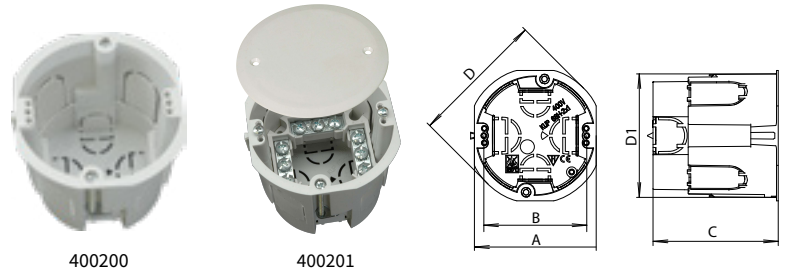

Ord. No. (Type)	Diameter (mm)	Depth (mm)	Inlet openings	Colour	Pkg. (pcs.)	Dimensions (mm)				
						A	B	C	D	D1
400200 (KUP 68H-201/3 LP SK)	71	73	4 x (21 x 33) 2 x (21 x 23) 2 x (17 x 21)	grey	54	71	60	73	79	72
400201 (KUP 68H-221/3 LP SK)										

Universal box for hollow walls

- New claws made from plastic.
- The metal screw features a double thread that speeds up the assembly into hollow walls.
- Thickness of the hollow wall 5 to 30 mm.
- Diameter of drilled holes 72 mm.

Complies with standards: STN EN 60670-1
Material: PP - self-extinguishing 30 s
Nominal insulation voltage: 400 V~
Glow wire test: 850 °C
Instal. on the surface of class (SK): materials A1 to E
Operating temperature: -25 °C to +60 °C

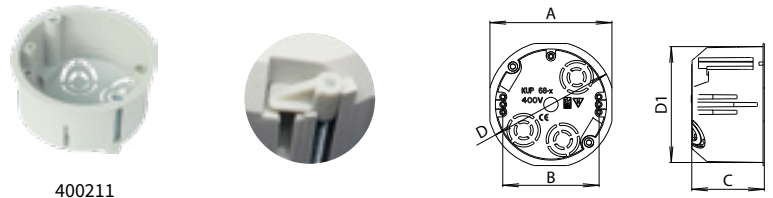

Ord. No. (Type)	Diameter (mm)	Depth (mm)	Inlet openings	Colour	Pkg. (pcs.)	Dimensions (mm)				
						A	B	C	D	D1
400211 (KUP 68 LP/SK)	79	45	3 x ø 21/12	grey	90	76	60	45	79	72

Universal box for hollow walls, double

- New claws made from plastic.
- The metal screw features a double thread that speeds up the assembly into hollow walls.
- Thickness of the hollow wall 5 to 30 mm.
- Diameter of drilled holes 68 mm.
- For installations into multiple frames.

Complies with standards: STN EN 60670-1
Material: PP - self-extinguishing 30 s
Nominal insulation voltage: 400 V~
Glow wire test: 850 °C
Instal. on the surface of class (SK): materials A1 to E
Operating temperature: -25 °C to +60 °C

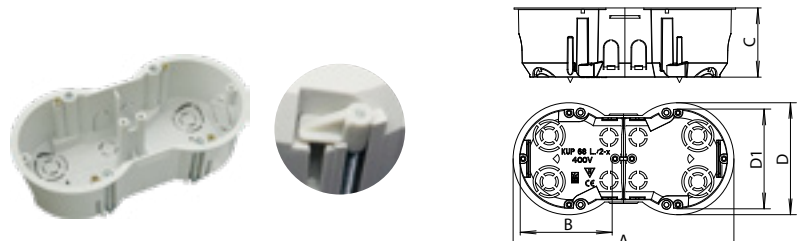

Ord. No. (Type)	Diameter (mm)	Depth (mm)	Inlet openings	Colour	Pkg. (pcs.)	Dimensions (mm)				
						A	B	C	D	D1
400212 (KUP 68 LP/2 SK)	144	45	4 x ø 21/12 4 x ø 12 2 x ø 21 4 x (10 x 18)	grey	70	144	60	45	73	68

Universal box for hollow walls, tripple

- New claws made from plastic.
- The metal screw features a double thread that speeds up the assembly into hollow walls.
- Thickness of the hollow wall 5 to 30 mm.
- Diameter of drilled holes 68 mm.
- Or installations into multiple frames.

Complies with standards: STN EN 60670-1
Material: PP - self-extinguishing 30 s
Nominal insulation voltage: 400 V~
Glow wire test: 850 °C
Instal. on the surface of class (SK): materials A1 to E
Operating temperature: -25 °C to +60 °C

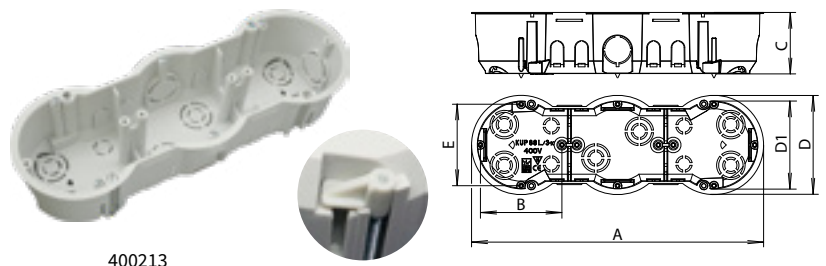

Ord. No. (Type)	Diameter (mm)	Depth (mm)	Inlet openings	Colour	Pkg. (pcs.)	Dimensions (mm)				
						A	B/E	C	D	D1
400213 (KUP 68 LP/3 SK)	215	45	6 x ø 21/12 4 x ø 12 4 x ø 21 8 x (10 x 18)	grey	80	215	60	45	73	68

Universal box for hollow walls, quadruple

- New claws made from plastic.
- The metal screw features a double thread that speeds up the assembly into hollow walls.
- Thickness of the hollow wall 5 to 30 mm.
- Diameter of drilled holes 68 mm.
- Or installations into multiple frames.

Complies with standards: STN EN 60670-1
 Material: PP - self-extinguishing 30 s
 Nominal insulation voltage: 400 V~
 Glow wire test: 850 °C
 Installation on the surface of class (SK): materials A1 to E
 Operating temperature: -25 °C to +60 °C



400214

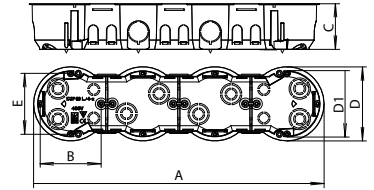

Ord. No. (Type)	Diameter (mm)	Depth (mm)	Inlet openings	Colour	Pkg. (pcs.)	Dimensions (mm)				
						A	B/E	C	D	D1
400214 (KUP 68 LP/4 SK)	286	45	8 x ø 21/12 4 x ø 12 6 x ø 21 12 x (10 x 18)	grey	30	286	60	45	73	68

Universal box for hollow walls, fivefold

- Thickness of the hollow wall 5 to 30 mm.
- Diameter of drilled holes 68 mm.
- Or installations into multiple frames.

Complies with standards: STN EN 60670-1
 Material: PP - self-extinguishing 30 s
 Nominal insulation voltage: 400 V~
 Glow wire test: 850 °C
 Installation on the surface of class (SK): materials A1 to E
 Operating temperature: -25 °C to +60 °C



400215

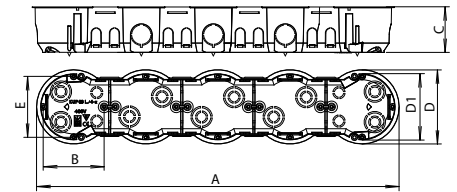

Ord. No. (Type)	Diameter (mm)	Depth (mm)	Inlet openings	Colour	Pkg. (pcs.)	Dimensions (mm)				
						A	B/E	C	D	D1
400215 (KUP 68 LA/5)	356	45	10 x ø 10/20 6 x ø 20 8 x (15 x 18) 8 x (10 x 18)	grey	60	356	60	45	73	68

Terminal ring 4P/3 clamps and 4P/4 clamps

- Used to connect installation cables in boxes.
- Ord. No. 400250 use with boxes Ord. No. 400100, 400101, 400110, 400200, 400501, 400511.
- Ord. No. 400251 use with boxes Ord. No. 400120.

Complies with standards: STN EN 60998-1
 STN EN 60998-2-1
 Degree of protection: IP00
 Material: PA - self-extinguishing 30 s, flame resistant
 Nominal insulation voltage: 400 V~
 Glow wire test: 850 °C
 Operating temperature: -25 °C to +60 °C



400250



400251

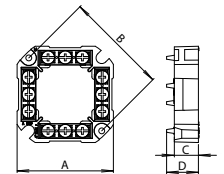

400250

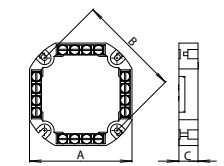

400251

Ord. No. (Type)	Rigid conductor cross section (mm ²)	Bridges / No. of terminals			Colour	Pkg. (pcs.)	Dimensions (mm)			
		L	N	PE			A	B	C	D
400250 (6303-13 P1/S)	4	3/3	1/3		grey	43	56	60	14	18,5
400251 (6303-15 P/S)	4	3/4	1/4		grey	60	86	86	16	-

Terminal ring 5P/4 clamps

- Used to connect installation cables in boxes.
- Ord. No. 400253 use with boxes Ord. No. 400120.

Complies with standards: STN EN 60998-1
 STN EN 60998-2-1
 Degree of protection: IP00
 Material: PA - self-extinguishing 30 s, flame resistant
 Nominal insulation voltage: 400 V~
 Glow wire test: 850 °C
 Operating temperature: -25 °C to +60 °C



400253

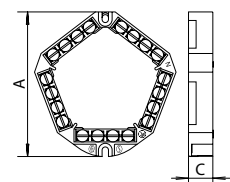

Ord. No. (Type)	Rigid conductor cross section (mm ²)	Bridges / No. of terminals			Colour	Pkg. (pcs.)	Dimensions (mm)	
		L	N	PE			A	C
400253 (6304-15/S)	4	3/4	1/4	1/4	grey	50	95	16

Junction boxes with elastic cut-off glands 45 x 90 mm

- Elastic cut-off glands.
- Snap-on lid.
- Adjusting elements allow easy in-line linking of boxes.
- A comprehensive range of "soft" branch boxes in three sizes with the function of in-line linking into assemblies.
- Holes for drained water can be cut off.

Complies with standards: STN EN 60670-1
 Degree of protection: IP54
 Material: PP-lid, PE - box
 Nominal insulation voltage: 400 V~
 Glow wire test: 650 °C
 Installation on the surface of class (SK): material A1
 Temperature: (STN EN 60670-1) -5 °C to +60 °C



400300

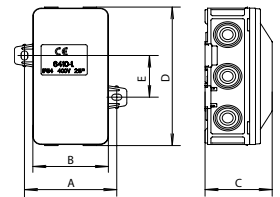

Ord. No. (Type)	Dimensions B x C x D (mm)	Sealing range (mm)	Inlet openings	Colour	Pkg. (pcs.)	Dimensions (mm)	
						A	E
400300 (6410-10)	45 x 40 x 90	5 - 10 7 - 14	10 x ø 6,5 10 x ø 9,5 from the bottom 2 x ø 5	grey	90	56	27

Junction boxes with elastic cut-off glands 90 x 90 mm

- Elastic cut-off glands.
- Snap-on lid.
- Adjusting elements allow easy in-line linking of boxes.
- A comprehensive range of "soft" branch boxes in three sizes with the function of in-line linking into assemblies.
- Holes for drained water can be cut off.

Complies with standards: STN EN 60670-1
 Degree of protection: IP54
 Material: PP-lid, PE - box
 Nominal insulation voltage: 400 V~
 Glow wire test: 650 °C
 Installation on the surface of class (SK): material A1
 Temperature: (STN EN 60670-1) -5 °C to +60 °C



400301

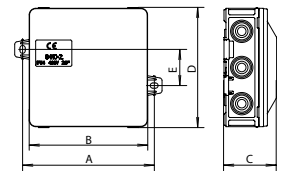

Ord. No. (Type)	Dimensions B x C x D (mm)	Sealing range (mm)	Inlet openings	Colour	Pkg. (pcs.)	Dimensions (mm)	
						A	E
400301 (6410-20)	90 x 40 x 90	5 - 10 7 - 14	14 x ø 6,5 14 x ø 9,5 from the bottom 4 x ø 5	grey	45	101	27

Junction boxes with elastic cut-off glands 135 x 90 mm

- Elastic cut-off glands.
- Snap-on lid.
- Adjusting elements allow easy in-line linking of boxes.
- A comprehensive range of "soft" branch boxes in three sizes with the function of in-line linking into assemblies.
- Holes for drained water can be cut off.

Complies with standards: STN EN 60670-1
 Degree of protection: IP54
 Material: PP-lid, PE - box
 Nominal insulation voltage: 400 V~
 Glow wire test: 650 °C
 Installation on the surface of class (SK): material A1
 Temperature: (STN EN 60670-1) -5 °C to +60 °C



400302

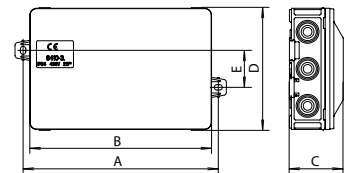

Ord. No. (Type)	Dimensions B x C x D (mm)	Sealing range (mm)	Inlet openings	Colour	Pkg. (pcs.)	Dimensions (mm)	
						A	E
400302 (6410-30)	135 x 40 x 90	5 - 10 7 - 14	18 x ø 6,5 18 x ø 9,5 from the bottom 4 x ø 5	grey	30	146	27

S-BOX Mini installation box with elastic cut-off glands

- Snap-on lid reduces box opening time by 90 %.
- Protection class II.
- Grey colour.

Complies with standards: STN EN 60670-1
 Degree of protection: IP44
 Mechanical resistance: IK08
 Material: ABS
 Nominal insulation voltage: 400 V~
 Glow wire test: 650 °C
 Installation on the surface of class (SK): material A1
 Operating temperature: -25 °C to +60 °C



400310

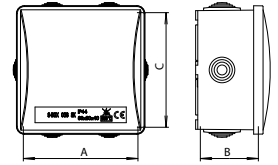

Ord. No. (Type)	Dimensions A x B x C (mm)	Elastic cut-off glands	Colour	Pkg. (pcs.)
400310 (S-Box 036)	80 x 40 x 80	6 x Pg 13,5 (ø 20,5 mm)	grey	150

S-BOX installation boxes with elastic cut-off glands

- Elements for attaching of electrical devices directly to the bottom of the box or using a DIN rail.
- 2 sets of mounting holes (inside/outside of the protected area) to be fixed up to two ways to the wall or the surface.
- Zinced screws with combi head.
- Protection class II.

Complies with standards: STN EN 60670-1
 Degree of protection: IP55
 Mechanical resistance: IK08
 Material: ABS
 Nominal insulation voltage: 400 V~
 Glow wire test: 650 °C
 Installation on the surface of class (SK): material A1
 Operating temperature: -25 °C to +60 °C



400351

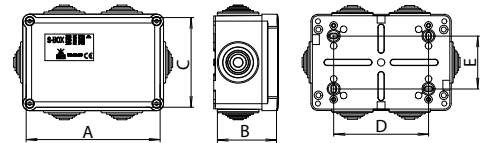

Ord. No. (Type)	Dimensions A x B x C (mm)	Elastic cut-off glands	Colour	Pkg. (pcs.)	Dimensions (mm)	
					D	E
400350 (S-Box 106)	100 x 50 x 100	6 x Pg 21 (ø 29 mm)	grey	90	60	60
400351 (S-Box 206)	120 x 50 x 80	6 x Pg 21 (ø 29 mm)		108	86	48
400352 (S-Box 306)	150 x 70 x 110	10 x Pg 21 (ø 29 mm)		50	116	72
400353 (S-Box 406)	190 x 70 x 140	10 x Pg 29 (ø 37 mm)		28	158	102
400354 (S-Box 506)	240 x 90 x 190	12 x Pg 29 (ø 37 mm)		14	206	152
400355 (S-Box 606)	300 x 120 x 220	12 x Pg 29 (ø 37 mm)		6	266	175
400356 (S-Box 706)	380 x 120 x 300	12 x Pg 29 (ø 37 mm)		5	289	259
400357 (S-Box 806)	460 x 120 x 380	18 x Pg 29 (ø 37 mm)		3	398	303

S-BOX installation boxes with plain walls (without glands)

- Elements for attaching of electrical devices directly to the bottom of the box or using a DIN rail.
- 2 sets of mounting holes (inside/outside of the protected area) to be fixed up to two ways to the wall or the surface.
- Zinced screws with combi head.
- Protection class II.

Complies with standards: STN EN 60670-1
 Degree of protection: IP66
 Degree of protection: IP56 (Ord. No. 400366, 400367)
 Mechanical resistance: IK08
 Material: ABS
 Nominal insulation voltage: 400 V~
 Glow wire test: 650 °C
 Installation on the surface of class (SK): material A1
 Operating temperature: -25 °C to +60 °C



400362

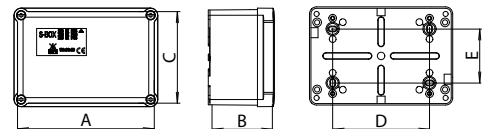

Ord. No. (Type)	Dimensions A x B x C (mm)	Elastic cut-off glands.	Colour	Pkg. (pcs.)	Dimensions (mm)	
					D	E
400360 (S-Box 116)	100 x 50 x 100	-	grey	90	60	60
400361 (S-Box 216)	120 x 50 x 80			108	86	48
400362 (S-Box 316)	150 x 70 x 110			50	116	72
400363 (S-Box 416)	190 x 70 x 140			28	158	102
400364 (S-Box 516)	240 x 90 x 190			14	206	152
400365 (S-Box 616)	300 x 120 x 220			6	266	175
400366 (S-Box 716)	380 x 120 x 300			5	289	259
400367 (S-Box 816)	460 x 120 x 380			3	398	303



Junction box with proven functionality in fire 105 x 105 mm

- Ceramic terminal blocks mounted on a metal carrier.
- The mounting of the box is done from inside through 2 holes in the carrier. Under the carrier are 2 metal spacer rollers, whose one end rests on the carrier bottom and the other end touches the wall or ceiling.
- Zinc plated screws with combi head.

Complies with standards:	STN 92 0205, class PS 90 ČSN 73 0895, class P 90-R DIN 4102-12, class E 90
Degree of protection:	IP55
Mechanical resistance:	IK08
Material:	PA - Halogen-free
Nominal insulation voltage:	400 V~
Glow wire test: Installation on the surface of class (SK):	850 °C material A1
Operating temperature:	-25 °C to +60 °C

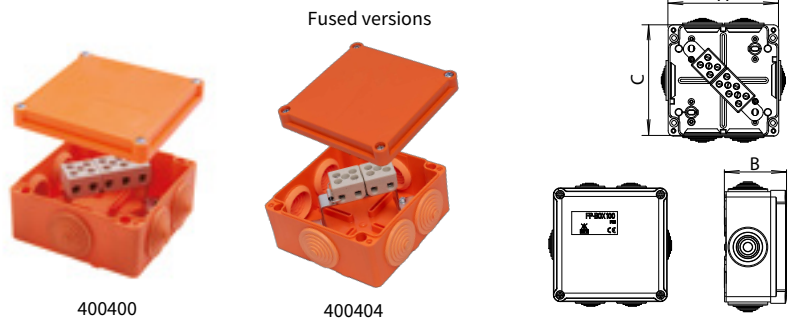

Ord. No. (Type)	Dimensions A x B x C (mm)	Elastic cut-off glands	Cross section (mm ²)	Ceramic terminal block	Mounting holes	Colour	Pkg. (pcs.)
400402 (PO 105 3P/4)	104,6 x 58,5 x 104,6	6 x Pg 21 (ø 29 mm)	4	3-pole	2 x ø 6,4 mm, spacing 60 x 60 mm	orange	12
400404 (PO 105 3P/4F)				4-pole			
400403 (PO 105 4P/4)				5-pole			
400400 (PO 105 5P/4)			10	3-pole			
400406 (PO 105 3P/10)				4-pole			
400405 (PO 105 3P/10F)				5-pole			
400401 (PO 105 5P/10)							

Order no. 400404, 400405 contain 4-pole terminal blocks, one pole intended for connecting of a thermal fuse TH 152 °C, 10A, 250V~.

Junction box with proven functionality in fire 125 x 85 mm

- Ceramic terminal blocks mounted on a metal carrier.
- The mounting of the box is done from inside through 2 holes in the carrier. Under the carrier are 2 metal spacer rollers, whose one end rests on the carrier bottom and the other end touches the wall or ceiling.
- Zinc plated screws with combi head.

Complies with standards:	STN 92 0205, class PS 90 ČSN 73 0895, class P 90-R DIN 4102-12, class E 90
Degree of protection:	IP55
Mechanical resistance:	IK08
Material:	PA - Halogen-free
Nominal insulation voltage:	400 V~
Glow wire test: Installation on the surface of class (SK):	850 °C material A1
Operating temperature:	-25 °C to +60 °C

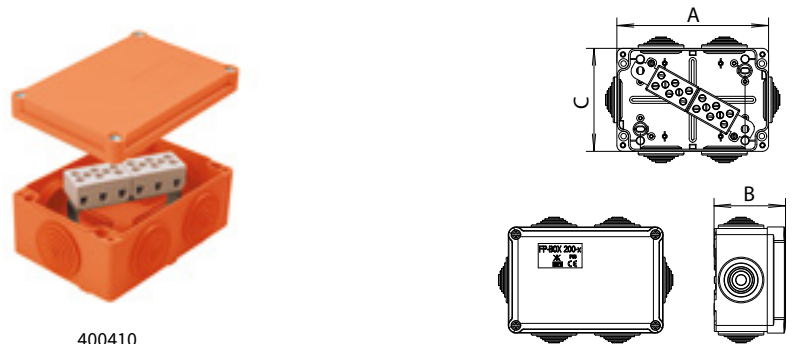

Ord. No. (Type)	Dimensions A x B x C (mm)	Elastic cut-off glands	Cross section (mm ²)	Ceramic terminal block	Mounting holes	Colour	Pkg. (pcs.)
400410 (PO 125 6P/4)	124,6 x 58,5 x 84,6	6 x Pg 21 (ø 29 mm)	4	6-pole	2 x ø 6,4 mm, spacing 86 x 48 mm	orange	9
400411 (PO 125 6P/10)			10				

Junction box with proven functionality in fire 155 x 115 mm

- Ceramic terminal blocks mounted on a metal carrier.
- The mounting of the box is done from inside through 2 holes in the carrier. Under the carrier are 2 metal spacer rollers, whose one end rests on the carrier bottom and the other end touches the wall or ceiling.
- Zinc plated screws with combi head.

Complies with standards:	STN 92 0205, class PS 90 ČSN 73 0895, class P 90-R DIN 4102-12, class E 90
Degree of protection:	IP55
Mechanical resistance:	IK08
Material:	PA - Halogen-free
Nominal insulation voltage:	400 V~
Glow wire test: Installation on the surface of class (SK):	850 °C material A1
Operating temperature:	-25 °C to +60 °C

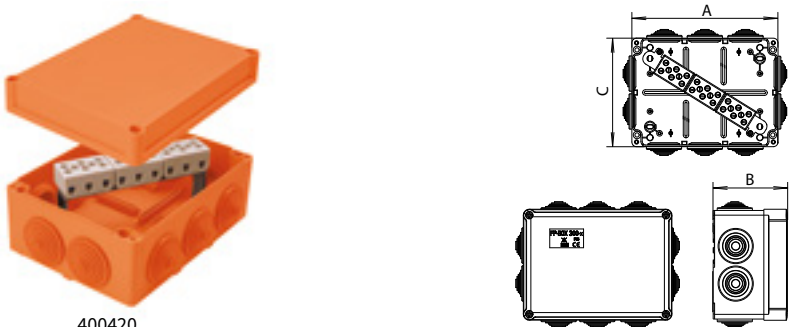

Ord. No. (Type)	Dimensions A x B x C (mm)	Elastic cut-off glands	Cross section (mm ²)	Ceramic terminal block	Mounting holes	Colour	Pkg. (pcs.)
400420 (PO 155 9P/4)	154,6 x 78,5 x 114,6	10 x Pg 21 (ø 29 mm)	4	9-pole	2 x ø 6,4 mm, spacing 116 x 72 mm	orange	6
400422 (PO 155 3P/10)			10	3-pole			
400423 (PO 155 6P/10)				6-pole			
400421 (PO 155 9P/10)				9-pole			

Note: Number of conductors that can be connected to the ceramic terminal blocks
Cross section 4 mm²: 10x 0,5mm²; 9x 0,75mm²; 8x 1mm²; 4x 1,5mm²; 3x 2,5mm²; 1x 4mm²; 1x 6mm²
Cross section 10 mm²: 10x 1mm²; 6x 1,5mm²; 4x 2,5mm²; 2x 4mm²; 1x 6mm²; 1x 10mm²

Junction surface trunking boxes 82 x 82 x 15,5 mm

- Installation holes 3 x ø16.
- For use with mounting rails.

Complies with standards: STN EN 60670-1
STN EN 60670-22
Degree of protection: IP40 - with lid
Material: PVC - self-extinguishing 30 s
Nominal insulation voltage: 400 V~
Glow wire test: 850 °C
Installation on the surface of class (SK): I_{max} ≤ 16 A - materials A1 to E
I_{max} > 16 A - material A1
Operating temperature: -25 °C to +60 °C

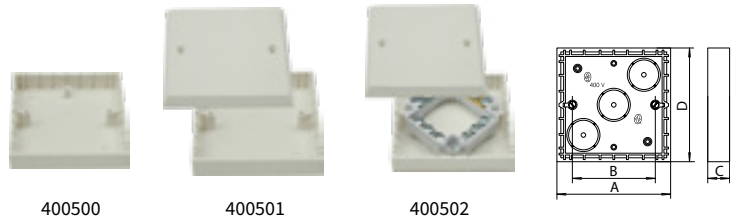

Ord. No. (Type)	Dimensions A x D x C (mm)	Accessories	Colour	Pkg. (pcs.)	Dimensions (mm)				
					A	B	C	D	E
400500 (6480-10)	82 x 82 x 15,5	-	grey	200	82	60	15,5	82	-
400501 (6481-10)	82 x 82 x 24	box lid + screws		48			24		
400502 (6481-14)	82 x 82 x 24	box lid + screws terminal ring 4P/3		48			24		

Junction surface trunking boxes 82 x 164 x 15,5 mm

- Installation holes 3 x ø16.
- For use with mounting rails.

Complies with standards: STN EN 60670-1
STN EN 60670-22
Degree of protection: IP40 with lid while both parts are covered.
Material: PVC - self-extinguishing 30 s
Nominal insulation voltage: 400 V~
Glow wire test: 850 °C
Installation on the surface of class (SK): I_{max} ≤ 16 A - materials A1 to E
I_{max} > 16 A - material A1
Operating temperature: -25 °C to +60 °C



Ord. No. (Type)	Dimensions A x D x C (mm)	Accessories	Colour	Pkg. (pcs.)	Dimensions (mm)				
					A	B	C	D	E
400510 (6482-10)	164 x 82 x 15,5	-	grey	100	164	60	15,5	82	-
400511 (6482-11)	164 x 82 x 27,5	box lid + screws		80			24		
400512 (6482-14)	164 x 82 x 27,5	box lid + screws terminal ring 4P/3		80			24		

Lid for surface trunking boxes 82 x 82 mm

- For use in surface trunking boxes.

Complies with standards: STN EN 60670-1
Material: PVC - self-extinguishing 30 s
Glow wire test: 850 °C
Operating temperature: -25 °C to +60 °C



Ord. No. (Type)	Dimensions A x D x C (mm)	Accessories	Colour	Pkg. (pcs.)	Dimensions (mm)			
					A	B	C	D
400520 (6483-11)	82 x 82 x 12	-	grey	200	82	60	12	82



Boxes with pre-injected cut-off holes and Pg glands - 660 V, IP65

- Used to connect installation cables in boxes.
- Ord. No. 400603, 400604, 400605, 400606 do not contain terminal rings.

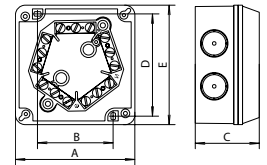

400600 - 400605

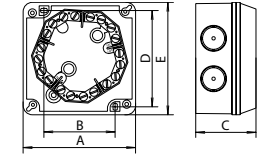

400606 - 400609



400600

Complies with standards:	STN EN 60670-1, STN EN 60670-22
Degree of protection:	IP65
Material:	PA, PVC - self-extinguishing 30 s
Nominal insulation voltage:	660 V~
Glow wire test:	960 °C - PA
Glow wire test:	850 °C - PVC
Installation on the surface of class (SK):	Imax ≤ 20 A - materials A1 to F Imax > 20 A - material A1
Operating temperature:	-25 °C to +60 °C

Ord. No. (Type)	Rigid conductor cross section (mm²)	Pre-injected cut-off holes (mm)	Pg glands (see page 151)	Terminal ring in the package	Colour	Pkg. (pcs.)	Dimensions (mm)				
							A	B	C	D	E
400600 (6457-10)	4	2 x Pg 16 + 4 x Pg 13,5	-	5P/3	grey	60	89	56	52,5	76	89
400601 (6457-11)			4 x Pg 13,5								
400602 (6457-13)			2 x Pg 13,5; 2 x Pg 16								
400603 (6457-15)	-	2 x Pg16 + 4 x Pg 13,5	4 x Pg 13,5; 2 x Pg 16	-	grey	60	89	56	52,5	76	89
400604 (6457-19)			-								
400605 (6457-19L)			-								
400606 (6457-20)	-	6 x Pg 21/Pg 16	-	-	grey	30	111	72	66	96	111
400607 (6457-21)	6 x Pg 16										
400608 (6457-22)	4 x Pg 16; 2 x Pg 21										
400609 (6457-23)	6	-	4 x Pg 16	-	-	-	-	-	-	-	-

Boxes with pre-injected holes and Pg elastic cut-off glands - 660 V, IP54

- Used to connect installation cables in boxes.
- Ord. No. 400603, 400604, 400605, 400606 do not contain terminal rings.

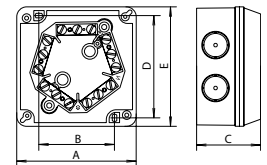

400620, 400621

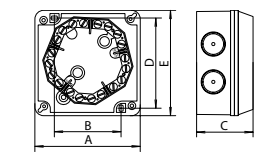

400622, 400623



400620

Complies with standards:	STN EN 60670-1, STN EN 60670-22
Degree of protection:	IP54
Material:	PA, PVC - self-extinguishing 30 s
Nominal insulation voltage:	660 V~
Glow wire test:	960 °C - PA
Glow wire test:	850 °C - PVC
Installation on the surface of class (SK):	Ord. No. 400620, 400622 Imax ≤ 39 A - materials A1 to F Imax > 39 A - material A1
Operating temperature:	-25 °C to +60 °C

Ord. No. (Type)	Rigid conductor cross section (mm²)	Pre-injected cut-off holes (mm)	Elastic cut-off glands Pg	Terminal ring in the package	Colour	Pkg. (pcs.)	Dimensions (mm)				
							A	B	C	D	E
400620 (6457-14)	-	-	6 x Pg 16	-	grey	44	89	56	52,5	76	89
400621 (6457-14 S)	4	-		5P/3							
400622 (6457-24)	-	-	6 x Pg 21	-	grey	50	111	72	66	96	111
400623 (6457-24 S)	6	-		5P/4							

Junction boxes Lava Line

- For flush mounting.
- Breakout holes on the sides and bottom of the box.

Degree of protection:	IP40
Material:	PS
Glow wire test:	650 °C
Nominal insulation voltage:	500 V~
Installation on the surface of class (SK):	material A1
Operating temperature:	-25 °C to +60 °C



400700



400703

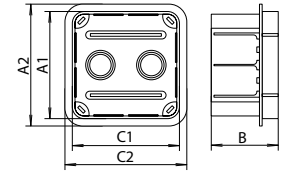

Ord. No. (Type)	Dimensions A2 x C2 (mm)	Outdoor dimensions A1 x C1 x B (mm)	Openings from the bottom of box (mm)	Openings from the side of box (mm)	Colour	Pkg. (pcs.)
400700 (Pp/t-1)	91 x 91	80 x 80 x 52	2 x ø 16/22	8 x (22 x 32)	orange	64
400701 (Pp/t-3)	111 x 111	100 x 100 x 62	2 x ø 16/22	8 x (32 x 32)		42
400702 (Pp/t-2)	91 x 131	80 x 120 x 52	2 x ø 16/22	4 x (23 x 32); 6 x (28 x 32)		42
400703 (Pp/t-4)	111 x 141	100 x 126 x 62	2 x ø 16/22	10 x (32 x 32)		36
400704 (Pp/t-5)	141 x 141	130 x 130 x 70	2 x ø 16/23/30	12 x (30 x 40)		45
400705 (Pp/t-7)	171 x 171	160 x 160 x 70	2 x ø 16/23/32/39	16 x (30 x 40)		28
400706 (Pp/t-6)	141 x 171	130 x 160 x 70	2 x ø 16/23/30	14 x (30 x 40)		36
400707 (Pp/t-8)	171 x 211	160 x 200 x 70	2 x ø 16/23/32/39	8 x (30 x 40); 8 x (40 x 40)		24
400708 (Pp/t-9)	211 x 211	200 x 200 x 70	4 x ø 16/23/32/39	16 x (30 x 40)		20

Lightning protection box

- For connecting the lightning protective conductor and the ground belt.
- Height adjustable for insulation up to 120 mm including the thickness of the plaster.
- Installation even without disassembly of the lightning protective conductor and the ground terminal connection.

Material:	PS
Glow wire test:	650 °C
Operating temperature:	-25 °C to +60 °C



400720

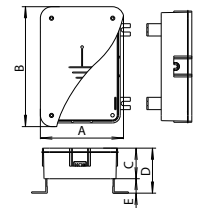

Ord. No. (Type)	Dimensions A x B (mm)	Colour	Pkg. (pcs.)	Dimensions (mm)				
				A	B	C	D	E
400720 (PZO)	168 x 218	orange	1	168	218	80	80-120	4-40



Pg industrial lamellar glands

- IP68 - tested on permanent immersion into depth of 1 m.
- They provide the dedicated sealing of the cable as well as its mechanical fastening.
- Colour grey.
- The seal is made of halogen-free plastic.
- Lamellar design ensures anti-vibration functionality.

Complies with standards: STN EN 62444
 Degree of protection: IP66 without washer, IP68 with sealing washer
 Material: PA-self-extinguishing 30 s
 Glow wire test: 850 °C
 Operating temperature: -20 °C to +80 °C



400800

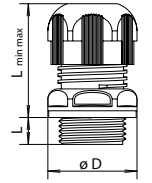

Ord. No. (Type)	Thread	Cable sealing range (mm)	Fixing clasp Type A, range (mm)	Assembly spanner of gland	Assembly spanner of nut	Tightening torque Mk/Nm	Resistance to Impact (J)	Pkg. (pcs.)	Dimensions (mm)				
									L	Lmin	Lmax	ØD	Assembly opening
400800 (TV-Pg 7)	Pg 7	3 - 7	-	16	-	2,5	1	50	8	17	21	16,5	13,0
400801 (TV-Pg 9)	Pg 9	4 - 9	9	20	-	3,8	2	50	8	21	25	21,0	15,7
400802 (TV-Pg 11)	Pg 11	4 - 9	9	20	-	3,8	2	50	8	21	25	21,0	19,1
400803 (TV-Pg 13)	Pg 13,5	7 - 12	11 - 12	24	-	3,8	2	250	10	25	30	26,5	20,9
400804 (TV-Pg 16)	Pg 16	7 - 14	9 - 14	26	-	5,0	2	170	10	26	31	28,0	23,0
400805 (TV-Pg 16-16)	Pg 16	8 - 16	9 - 16	30	-	5,0	2	150	10	30	37,5	33,0	23,0
400806 (TV-Pg 21)	Pg 21	11 - 18	12 - 18	30	-	7,5	4	120	10	29	38	33,5	29,0
400807 (TV-Pg 21-20)	Pg 21	11 - 20	12 - 20	36	-	7,5	4	100	12	35	45	40,0	29,0
400808 (TV-Pg 29)	Pg 29	14 - 26	16 - 26	46	-	7,5	4	50	12	40	50	51,0	37,5
400809 (TV-Pg 36)	Pg 36	23 - 36	30 - 36	55	-	7,5	7	30	14	50	60	61,0	47,5

Pg industrial lamellar glands with nut

- IP68 - tested on permanent immersion into depth of 1 m.
- They provide the dedicated sealing of the cable as well as its mechanical fastening.
- Colour grey.
- The seal is made of halogen-free plastic.
- Lamellar design ensures anti-vibration functionality.

Complies with standards: STN EN 62444
 Degree of protection: IP66 without washer, IP68 with sealing washer
 Material: PA- self-extinguishing 30 s
 Glow wire test: 850 °C
 Operating temperature: -20 °C to +80 °C



400824

400826

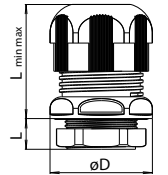

Ord. No. (Type)	Thread	Cable sealing range (mm)	Fixing clasp Type A, range (mm)	Assembly spanner of gland	Assembly spanner of nut	Tightening torque Mk/Nm	Resistance to Impact (J)	Pkg. (pcs.)	Dimensions (mm)				
									L	Lmin	Lmax	ØD	Assembly opening
400820 (TVM-Pg 7)	Pg 7	3 - 7	-	16	16	2,5	1	50	8	17	21	16,5	13,0
400821 (TVM-Pg 9)	Pg 9	4 - 9	9	20	19	3,8	2	50	8	21	25	21,0	15,7
400822 (TVM-Pg 11)	Pg 11	4 - 9	9	20	22	3,8	2	50	8	21	25	21,0	19,1
400823 (TVM-Pg 13)	Pg 13,5	7 - 12	11 - 12	24	24	3,8	2	200	10	25	30	26,5	20,9
400824 (TVM-Pg 16)	Pg 16	7 - 14	9 - 14	26	27	5,0	2	150	10	26	31	28,0	23,0
400825 (TVM-Pg 16-16)	Pg 16	8 - 16	9 - 16	30	27	5,0	2	130	10	30	37,5	33,0	23,0
400826 (TVM-Pg 21)	Pg 21	11 - 18	12 - 18	30	32	7,5	4	100	10	29	38	33,5	29,0
400827 (TVM-Pg 21-20)	Pg 21	11 - 20	12 - 20	36	32	7,5	4	80	12	35	45	40,0	29,0
400828 (TVM-Pg 29)	Pg 29	14 - 26	16 - 26	46	41	7,5	4	40	12	40	50	51,0	37,5
400829 (TVM-Pg 36)	Pg 36	23 - 36	30 - 36	55	55	7,5	7	30	14	50	60	61,0	47,5

Pg lamellar glands ECO

- They provide the dedicated sealing of the cable as well as its mechanical fastening.
- Supplied with nut.
- Lamellar design ensures anti-vibration functionality.

Complies with standards: STN EN 62444
 Degree of protection: IP68
 Material: PP
 Glow wire test: 650 °C
 Operating temperature: -30 °C to +80 °C

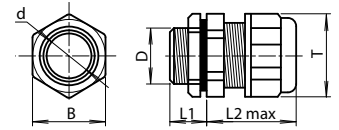

400840 400843 400846 400849

Ord. No. (Type)	Thread	Cable sealing range (mm)	Assembly spanner of gland	Assembly spanner of nut	Tightening torque Mk/Nm	Resistance to Impact (J)	Colour	Pkg. (pcs.)	Dimensions (mm)					
									L1	L2max	D	T	B	d
400840 (Pg 7)	Pg 7	3,5 - 6,5	16	18	2,5	1	grey	25	8,1	23,5	12,2	16,8	17,3	7,0
400841 (Pg 9)	Pg 9	4,5 - 7	19	22	3,8	2		25	8,1	26	15,2	20,3	20,7	8,5
400842 (Pg 11)	Pg 11	5,5 - 10	22	24	3,8	2		25	8,1	28	18,6	23,7	23,3	10,5
400843 (Pg 13)	Pg 13,5	9 - 13	24	27	3,8	2		25	9,1	29,5	20,4	25,7	26,2	12,5
400844 (Pg 16)	Pg 16	10 - 14	27	30	5,0	2		20	10,0	29,5	22,5	28,5	28,8	14,5
400845 (Pg 21)	Pg 21	14 - 17,5	32	36	7,5	4		10	10,0	34	28,3	34,6	35,7	18,5
400846 (Pg 29)	Pg 29	18 - 25	41	45	7,5	4		5	15,1	38,2	37,4	45,6	45,1	25,5
400847 (Pg 36)	Pg 36	25 - 32	50	57	7,5	7		2	15,1	46,5	47,0	58,2	56,7	32,5
400848 (Pg 42)	Pg 42	30 - 37,5	60	65	7,5	7		2	15,1	50,5	53,8	68,0	64,6	38,5
400849 (Pg 48)	Pg 48	37 - 44	62	70	7,5	7		2	15,1	50,5	59,3	72,0	69,9	44,5

Pg nuts

- Flange design allows secure mounting.

Material: PA- self-extinguishing 30 s
 Glow wire test: 850 °C
 Operating temperature: -20 °C to +80 °C



400860

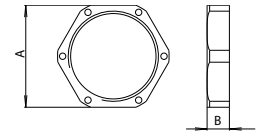

Ord. No. (Type)	Thread	Tightening torque Mk/Nm	Colour	Pkg. (pcs.)	Dimensions (mm)	
					A	B
400860 (UM 7/02)	Pg 7	2,5	grey	700	16	3,5
400861 (UM 9/02)	Pg 9	3,8		500	19	3,5
400862 (UM 11/02)	Pg 11	3,8		1800	22	4,5
400863 (UM 13/02)	Pg 13,5	3,8		2000	24	5,0
400864 (UM 16/02), (UM 16-16/02)	Pg 16	5,0		1400	27	6,0
400865 (UM 21/02), (UM 21-20/02)	Pg 21	7,5		1000	32	7,0
400866 (UM 29/02)	Pg 29	7,5		450	41	8,0
400867 (UM 36/02)	Pg 36	7,5		330	55	9,0

Sealing washers for Pg glands

- To increase the IP of Pg glands.

Material: Rubber
 Operating temperature: -20 °C to +80 °C



400880

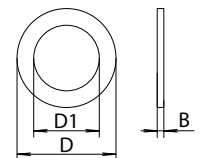

Ord. No. (Type)	For gland	Colour	Pkg. (pcs.)	Dimensions (mm)		
				D	D1	B
400880 (TP 7)	Pg 7	black	400	15,5	12,5	1,5
400881 (TP 9)	Pg 9		400	19	15,5	
400882 (TP 11)	Pg 11		300	22	18,9	
400883 (TP 13)	Pg 13,5		200	26	19,3	
400884 (TP 16), (TP16-16)	Pg 16		200	28	21,4	2,0
400885 (TP 21), (TP20-21)	Pg 21		300	35	27,0	
400886 (TP 29)	Pg 29		70	45	35,7	
400887 (TP 36)	Pg 36		60	54	45,7	



Metric lamellar cable glands

- IP68 - tested on permanent immersion into depth of 1 m.
- They provide the dedicated sealing of the cable as well as its mechanical fastening.
- Colour grey.
- The seal is made of halogen-free plastic.
- Lamellar design ensures anti-vibration functionality.

Complies with standards: STN EN 62444
 Degree of protection: IP66 without washer, IP68 with sealing washer
 Material: PA- self-extinguishing 30 s
 Glow wire test: 850 °C
 Operating temperature: -20 °C to +80 °C



400900

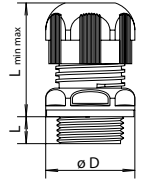

Ord. No. (Type)	Thread	Cable sealing range (mm)	Fixing clasp Type A, range (mm)	Assembly spanner of gland	Assembly spanner of nut	Tightening torque Mk/Nm	Resistance to Impact (J)	Pkg. (pcs.)	Dimensions (mm)				
									L	Lmin	Lmax	ØD	Assembly opening
400900 (TV-M 12)	M 12 x 1,5	3 - 7	-	16	-	2,5	1	50	8,0	17	21	16,5	12,5
400901 (TV-M 16)	M 16 x 1,5	4 - 9	9	20	-	3,8	2	50	8,0	21	25	21,0	16,5
400902 (TV-M 20)	M 20 x 1,5	7 - 12	11 - 12	24	-	5,0	2	250	10,0	25	30	26,5	20,5
400903 (TV-M 25)	M 25 x 1,5	8 - 16	9 - 16	30	-	7,5	2	150	10,0	30	37,5	33,0	25,5
400904 (TV-M 32)	M 32 x 1,5	11 - 20	12 - 20	36	-	10,0	4	100	12,0	35	45	40,0	32,5
400905 (TV-M 40)	M 40 x 1,5	14 - 26	16 - 26	46	-	10,0	4	50	12,0	40	50	51,0	40,5
400906 (TV-M 50)	M 50 x 1,5	23 - 36	30 - 36	55	-	10,0	7	30	14,0	50	60	61,0	50,5
400907 (TV-M 63)	M 63 x 1,5	28 - 45	32 - 45	70	-	10,0	7	16	14,0	55	65	78,0	63,5

Metric lamellar cable glands with nut

- IP68 - tested on permanent immersion into depth of 1 m.
- They provide the dedicated sealing of the cable as well as its mechanical fastening.
- Colour grey.
- The seal is made of halogen-free plastic.
- Lamellar design ensures anti-vibration functionality.

Complies with standards: STN EN 62444
 Degree of protection: IP66 without washer, IP68 with sealing washer
 Material: PA- self-extinguishing 30 s
 Glow wire test: 850 °C
 Operating temperature: -20 °C to +80 °C



400920

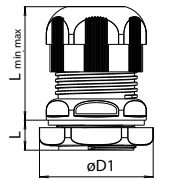

Ord. No. (Type)	Thread	Cable sealing range (mm)	Fixing clasp Type A, range (mm)	Assembly spanner of gland	Assembly spanner of nut	Tightening torque (Mk/Nm)	Resistance to Impact (J)	Pkg. (pcs.)	Dimensions (mm)				
									L	Lmin	Lmax	ØD1	Assembly opening
400920 (TVM-M 12)	M 12 x 1,5	3 - 7	-	16	16	2,5	1	50	8,0	17	21	17,6	12,5
400921 (TVM-M 16)	M 16 x 1,5	4 - 9	9	20	22	3,8	2	50	8,0	21	25	24,5	16,5
400922 (TVM-M 20)	M 20 x 1,5	7 - 12	11 - 12	24	27	5,0	2	200	10,0	25	30	30	20,5
400923 (TVM-M 25)	M 25 x 1,5	8 - 16	9 - 16	30	34	7,5	2	130	10,0	30	37,5	37,5	25,5
400924 (TVM-M 32)	M 32 x 1,5	11 - 20	12 - 20	36	41	10,0	4	80	12,0	35	45	45,5	32,5
400925 (TVM-M 40)	M 40 x 1,5	14 - 26	16 - 26	46	50	10,0	4	40	12,0	40	50	55,5	40,5
400926 (TVM-M 50)	M 50 x 1,5	23 - 36	30 - 36	55	60	10,0	7	30	14,0	50	60	66,5	50,5
400927 (TVM-M 63)	M 63 x 1,5	28 - 45	32 - 45	70	75	10,0	7	16	14,0	55	65	83,5	63,5

Metric nuts

- Flange design allows secure mounting.

Material: PA- self-extinguishing 30 s
 Glow wire test: 850 °C
 Operating temperature: -20 °C to +80 °C



400940

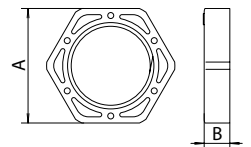

Ord. No. (Type)	Thread	Tightening torque (Mk/Nm)	Colour	Pkg. (pcs.)	Dimensions (mm)	
					A	B
400940 (UM-M 12/02)	M 12 x 1,5	2,5	grey	200	16	4,5
400941 (UM-M 16/02)	M 16 x 1,5	3,8		200	22	4,5
400942 (UM-M 20/02)	M 20 x 1,5	5,0		250	27	6,0
400943 (UM-M 25/02)	M 25 x 1,5	7,5		800	34	6,0
400944 (UM-M 32/02)	M 32 x 1,5	10,0		80	41	7,0
400945 (UM-M 40/02)	M 40 x 1,5	10,0		50	50	7,0
400946 (UM-M 50/02)	M 50 x 1,5	10,0		30	60	8,0
400947 (UM-M 63/02)	M 63 x 1,5	10,0		10	75	8,0

Sealing washers for Metric glands

- To increase the IP of metric glands.



400960

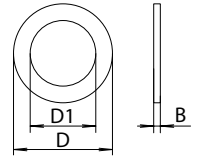

Material:	Rubber
Operating temperature:	-20 °C to +80 °C

Ord. No. (Type)	For gland	Colour	Pkg. (pcs.)	Dimensions (mm)		
				D	D1	B
400960 (TP-M 12)	M 12	black	500	16	12,0	1,0
400961 (TP-M 16)	M 16		500	20,5	16,0	1,0
400962 (TP-M 20)	M 20		500	25	20,0	1,5
400963 (TP-M 25)	M 25		300	31	25,0	1,5
400964 (TP-M 32)	M 32		250	38	32,0	2,0
400965 (TP-M 40)	M 40		150	48	40,0	2,0
400966 (TP-M 50)	M 50		60	59,4	50,4	2,0
400967 (TP-M 63)	M 63		50	76	63,0	2,0

Metric sealing plugs

- IP 67 with sealing washer for metric glands.



400980

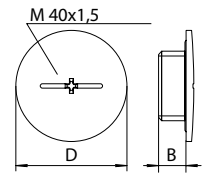

Degree of protection:	IP54 - without washer IP 67 - with sealing washer
Material:	ABS
Operating temperature:	-20 °C to +80 °C

Ord. No. (Type)	Thread	Colour	Pkg. (pcs.)	Dimensions (mm)	
				D	B
400980 (TZ-M 20)	M 20 x 1,5	grey	350	26,5	10,0
400981 (TZ-M 25)	M 25 x 1,5		200	33	10,0
400982 (TZ-M 32)	M 32 x 1,5		120	40	12,0
400983 (TZ-M 40)	M 40 x 1,5		80	51	12,0

Cable connectors 5-pole

- For connecting of multicore cables in a fixed electrical installations.
- Not intended for ground installation.

Complies with standards:	STN EN 60947-7-1
Degree of protection:	IP67
Material:	ABS - cover PA - terminal block
Nominal insulation voltage:	400 V~
Glow wire test:	cover 650 °C, terminal block 850 °C
Operating temperature:	-25 °C to +40 °C



401000

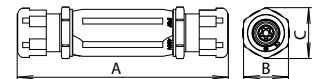

Ord. No. (Type)	Cross section (mm ²)	Stripped wire (mm)	Sealing range of gland (mm)	Max. current (A)	Pkg. (pcs.)	Dimensions (mm)		
						A	B	C
401000 (SP 2,5)	5 x (1 - 2,5)	5	10 - 14	20	14	126	27	30
401001 (SP 6)	5 x (2,5 - 6)	7	13 - 18	30		145	33	36

Cable connector 1-pole

- Not intended for ground installation.

Complies with standards:	STN EN 60947-7-1
Degree of protection:	IP67
Material:	ABS
Nominal insulation voltage:	400 V~
Glow wire test:	650 °C
Operating temperature:	-25 °C to +40 °C



401010

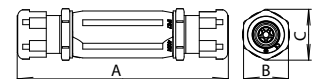

Ord. No. (Type)	Cross section (mm ²)	Sealing range of gland (mm)	Max. current (A)	Pkg. (pcs.)	Dimensions (mm)		
					A	B	C
401010 (SP 35)	1 x (16 - 35)	6,4 - 12	125	14	126	27	30



Polyamide cable clips

- Side by side linkable.
- Max. power side/axial 45N/45N.
- Resistance to impact - 2 J - medium.



401050

Complies with standards: STN EN 61914
 Material: PA - self-extinguishing 30 s
 Glow wire test: 850 °C
 Operating temperature: -25 °C to +85 °C

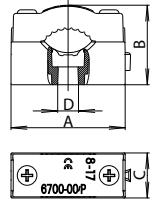

Ord. No. (Type)	Cable diameter (mm)	Dimensions A x B x C (mm)	Oval hole D (mm)	Pkg. (pcs.)
401050 (6700-00/P)	8 - 17	32 x 22 x 12,5	4 x 5,5*	200
401051 (6701-00/P)	17 - 25	44 x 32 x 15	4 x 5,5*	300

* Oval opening for the screw Ø 4 mm.

1-pole 3x (1-4) mm² insulated terminals for boxes

- For connecting of several stripped conductors.
- Oval opening for the screw Ø 4 mm.

Complies with standards: STN EN 60947-7-1
 Degree of protection: IP10
 Material: PA- self-extinguishing 30 s
 Glow wire test: 850 °C
 Nominal insulation voltage: 400 V~,
 Operating temperature: -25 °C to +60 °C



401060

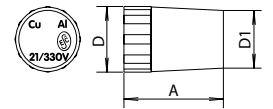

Ord. No. (Type)	Rigid conductor cross section (mm ²)	Dimensions A x D x D1 (mm)	Stripped wire (mm)	Pkg. (pcs.)
401060 (6100-04)	3 x (1 - 2,5)	20,5 x 14 x 13	14	500
401061 (6100-15)	3 x (1 - 4)	25 x 18 x 14,5	16	250

1-pole 3x (6-16) mm² insulated terminals for boxes

- Allows insertion of the main wire without its interruption.

Complies with standards: STN EN 60947-7-1
 Degree of protection: IP10
 Material: PA- self-extinguishing 30 s
 Glow wire test: 850 °C
 Nominal insulation voltage: 400 V~,
 Operating temperature: -25 °C to +60 °C



401070

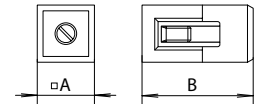

Ord. No. (Type)	Rigid conductor cross section (mm ²)	Stripped wire (mm)	Pkg. (pcs.)	Dimensions (mm)	
				A	B
401070 (6100-44)	3 x (6 - 16)	17	170	19	35

Dowels

- For fixing of screws into various material types.

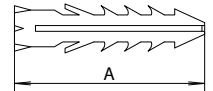

Material: PE
Operating temperature: -25 °C to +60 °C

401080

Ord. No. (Type)	Diameter hole (mm)	Diameter screw (mm)	Length screw (mm)	A (mm)	Pkg. (pcs.)
401080 (H 6)	6	2 - 4	15 - 30	30	200
401081 (H 8)	8	3 - 5	20 - 40	40	200
401082 (H 10)	10	4 - 6	25 - 50	50	200
401083 (H 12)	12	4 - 8	40 - 60	60	100

Cable ties - natural, black - UV

- Natural - resistant to oils, petrol, salt water and solvents.
- Black - UV resistant, suitable for outdoor use.

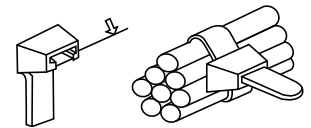

Material: PA 6,6 - halogen-free
Operating temperature: -40 °C to +85 °C

401100

401200

Ord. No. (Type)	Dimension (mm)	Colour	Pkg. (pcs.)
401100 (VPN 2-100)	2 x 100	natural	100
401101 (VPN 2-135)	2 x 135		
401102 (VPN 2-160)	2 x 160		
401103 (VPN 2-200)	2 x 200		
401104 (VPN 4-140)	4 x 140		
401105 (VPN 4-200)	4 x 200		
401106 (VPN 4-280)	4 x 280		
401107 (VPN 4-360)	4 x 360		
401108 (VPN 5-200)	5 x 200		
401109 (VPN 5-250)	5 x 250		
401110 (VPN 5-280)	5 x 280		
401111 (VPN 5-360)	5 x 360		
401112 (VPN 5-380)	5 x 380		
401113 (VPN 5-430)	5 x 430		
401114 (VPN 8-200)	8 x 200		
401115 (VPN 8-280)	8 x 280		
401116 (VPN 8-360)	8 x 360		
401117 (VPN 8-450)	8 x 450		
401118 (VPN 8-540)	8 x 540		
401119 (VPN 8-710)	8 x 710		
401121 (VPN 9-780)	9 x 780		
401122 (VPN 13-500)	13 x 500		
401123 (VPN 13-730)	13 x 730		
401125 (VPN 13-1000)	13 x 1000		

Ord. No. (Type)	Dimension (mm)	Colour	Pkg. (pcs.)
401200 (VPB 2-100)	2 x 100	black	100
401201 (VPB 2-135)	2 x 135		
401202 (VPB 2-160)	2 x 160		
401203 (VPB 2-200)	2 x 200		
401204 (VPB 4-140)	4 x 140		
401205 (VPB 4-200)	4 x 200		
401206 (VPB 4-280)	4 x 280		
401207 (VPB 4-360)	4 x 360		
401208 (VPB 5-200)	5 x 200		
401209 (VPB 5-250)	5 x 250		
401210 (VPB 5-280)	5 x 280		
401211 (VPB 5-360)	5 x 360		
401212 (VPB 5-380)	5 x 380		
401213 (VPB 5-430)	5 x 430		
401214 (VPB 8-200)	8 x 200		
401215 (VPB 8-280)	8 x 280		
401216 (VPB 8-360)	8 x 360		
401217 (VPB 8-450)	8 x 450		
401218 (VPB 8-540)	8 x 540		
401219 (VPB 8-710)	8 x 710		
401221 (VPB 9-780)	9 x 780		
401222 (VPB 13-500)	13 x 500		
401223 (VPB 13-730)	13 x 730		
401225 (VPB 13-1000)	13 x 1000		



Self-adhesive cable tie base

- For cable ties fastening.

Material: ABS
 Flammability classification: UL94 class HB
 Operating temperature: -10 °C to +60 °C

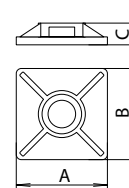
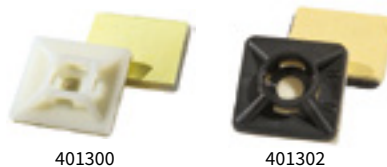

Ord. No. (Type)	Dimension A x B (mm)	Height C (mm)	Colour	Pkg. (pcs.)
401300 (USN 19-19)	19 x 19	5,0	natural	100
401301 (USN 29-29)	29 x 29			
401302 (USB 19-19)	19 x 19	6,5	black	100
401303 (USB 29-29)	29 x 29			

Cable tie dowel base

- For cable ties fastening.

Material: PA 6.6
 Operating temperature: -10 °C to +65 °C



401310

Ord. No. (Type)	Width (mm)	Dĺžka (mm)	Max. width cable (mm)	Colour	Pkg. (pcs.)
401310 (UZB 9-43)	9,7	43,5	9	black	100





CONTENTS

Terminal components	160
Cable lugs - tubular	164
Cable lugs, crimping pliers, cable connectors	165
Cable lugs - crimping	166
Bolt-on cable lugs, cupal washers, terminal pins	167
Insulated cable connectors, flat female, male	168
Insulated flat male, female and fork terminals	169
Insulated cable lugs and cable sleeves	170
Insulated cable sleeves and pin terminals	171
Multipole flat male and female terminals and insulator	172
Bolt-on flat male and double male terminals	173
Multipole flat male and female terminals, multipole palstic sockets and plugs	174
Multipole plastic sockets and plugs combined	175



A long term development of this assortment in SEZ DK a.s. guarantees compliance with all the relevant technical standards. Our terminal components are manufactured from high quality brass and copper raw materials and are specially surface treated to provide the lowest transient resistance and maximum protection against corrosion, long-lasting and reliable operation.

We offer following production groups within our portfolio of terminal components for crimping and connecting of copper wires and cables::

- Crimping cable lugs and tubular lugs
- Bolt-on cable lugs, cupal (Cu-Al) washers, insulated pin terminals
- Insulated cable connectors, flat female, male and fork terminals
- Flat female and male terminals (fastons) without insulation
- Bolt-on flat male and double male terminals
- Multipole flat male and female terminals, multipole sockets and plugs

AREA OF APPLICATION:

- Instruments / Controls
- Lighting
- Power supplies
- Distribution assemblies and switchgears
- Distribution
- Lifting equipments
- Electric motors
- Machinery and equipment

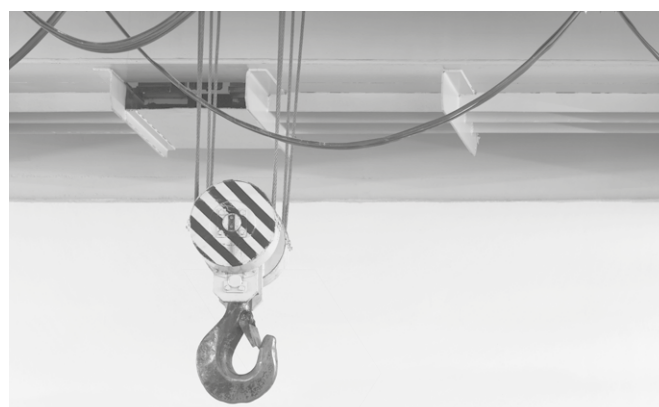
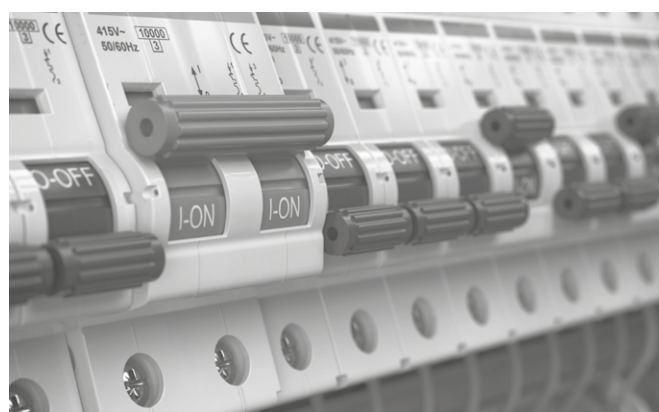

Crimping cable lugs – tubular

- Application: for flexible Cu conductors.
- They are manufactured from galvanically tinned electrolytically clean copper plate. They are provided with a closed circular profile conductor bed designed to be pressed and permanently attached to both rigid and flexible copper conductors.



500000

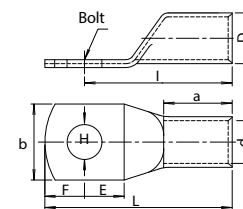

Complies with standards: EN IEC 61238-1-1, 61238-1-3
Material: Copper
Surface treatment: Tinning

Ord. No. (Type)	Cross section (mm ²)	Bolt	Pkg. (pcs.)	Dimensions (mm)									
				H	D	d	E	F	a	b	l	L	
500000 (K1,5/4)	1,5	M4	100	4,4	3,3	1,8	5,0	4,5	6,5	6,5	13,5	18,0	
500001 (K1,5/5)		M5		5,5			5,5	5,0		7,5	14,0	19,0	
500002 (K1,5/6)		M6		6,5			6,0	5,5		9,0	14,5	20,0	
500004 (K2,5/4)	2,5	M4	100	4,4	4,1	2,4	5,5	4,5	6,5	7,5	14,5	19,0	
500005 (K2,5/5)		M5		5,5			6,0	5,0		8,5	15,0	20,0	
500006 (K2,5/6)		M6		6,5			6,5	5,5		9,5	15,5	21,0	
500007 (K2,5/8)		M8		8,5			7,5	6,5		12,0	17,5	24,0	
500008 (K4/4)	4	M4	100	4,4	5,3	3,0	6,0	5,5	8,5	8,0	18,5	24,0	
500009 (K4/5)		M5		5,5			6,5	6,0		9,0	19,0	25,0	
500010 (K4/6)		M6		6,5			7,5	7,0		11,0	20,0	27,0	
500011 (K4/8)		M8		8,5			8,5	8,0		14,0	21,0	29,0	
500012 (K6/5)	6	M5	100	5,5	6,5	3,5	6,5	6,0	10,0	10,5	21,5	27,5	
500013 (K6/6)		M6		6,5			7,0	6,5		11,5	22,0	28,5	
500014 (K6/8)		M8		8,5			8,0	7,5		15,5	23,0	30,5	
500015 (K6/10)		M10		10,5			10,0	9,0		17,0	25,5	34,5	
500016 (K10/5)	10	M5	100	5,5	7,0	4,5	7,0	6,0	10,0	12,0	22,0	28,0	
500017 (K10/6)		M6		6,5			7,5	6,5		12,0	22,5	29,0	
500018 (K10/8)		M8		8,5			8,5	7,5		14,5	23,5	31,0	
500019 (K10/10)		M10		10,5			10,5	9,0		17,0	25,5	34,5	
500020 (K16/5)	16	M5	100	5,5	8,5	5,5	7,0	6,0	13,0	12,0	27,0	33,0	
500021 (K16/6)		M6		6,5			7,5	6,5		12,0	27,5	34,0	
500022 (K16/8)		M8		8,5			9,0	8,0		14,0	29,0	37,0	
500023 (K16/10)		M10		10,5			11,0	10,0		17,0	31,0	41,0	
500024 (K16/12)		M12		13,0			13,0	12,0		20,0	33,0	45,0	
500025 (K25/6)	25	M6	100	6,4	10,0	7,0	7,5	6,5	14,0	14,0	28,5	35,0	
500026 (K25/8)		M8		8,3			9,0	8,0		16,0	30,0	38,0	
500027 (K25/10)		M10		10,3			11,0	10,0		17,5	32,0	42,0	
500028 (K25/12)		M12		13,0			13,0	12,0		20,0	34,0	46,0	
500029 (K35/6)	35	M6	100	6,5	12,0	8,5	9,0	8,5	16,0	18,0	33,0	41,5	
500030 (K35/8)		M8		8,5			10,0	9,0		18,0	34,0	43,0	
500031 (K35/10)		M10		10,5			11,0	10,0		18,0	35,0	45,0	
500032 (K35/12)		M12		13,0			13,0	12,0		22,0	37,0	49,0	
500033 (K50/6)	50	M6	100	6,5	14,0	10,0	9,0	8,0	17,0	20,0	37,0	45,0	
500034 (K50/8)		M8		8,5			10,0	9,0		20,0	38,0	47,0	
500035 (K50/10)		M10		10,5			12,0	10,0		21,0	40,0	50,0	
500036 (K50/12)		M12		13,0			14,0	11,0		23,0	45,0	56,0	
500037 (K50/16)		M16		17,0			16,0	14,0		26,0	47,0	61,0	
500038 (K70/6)	70	M6	50	6,5	16,5	12,0	10,0	9,0	20,0	23,0	41,0	50,0	
500039 (K70/8)		M8		8,5			11,0	10,0		23,0	42,0	52,0	
500040 (K70/10)		M10		10,5			12,0	11,0		23,0	43,0	54,0	
500041 (K70/12)		M12		13,0			14,0	12,0		23,0	45,0	57,0	
500042 (K70/16)		M16		17,0			17,0	14,0		29,0	47,0	61,0	
500043 (K95/8)	95	M8	50	8,5	18,0	13,5	11,0	10,0	23,0	26,0	49,0	59,0	
500044 (K95/10)		M10		10,5			12,0	11,0		26,0	50,0	61,0	
500045 (K95/12)		M12		13,0			14,0	12,0		26,0	52,0	64,0	
500046 (K95/16)		M16		17,0			17,0	14,0		31,0	55,0	69,0	
500048 (K120/8)	120	M8	50	8,5	19,5	15,0	12,0	11,0	26,0	28,0	55,0	66,0	
500049 (K120/10)		M10		10,5			13,0	12,0		28,0	56,0	68,0	
500050 (K120/12)		M12		13,0			15,0	13,0		28,0	58,0	71,0	
500051 (K120/16)		M16		17,0			17,0	15,0		29,0	60,0	75,0	

Crimping cable lugs – tubular

(continuing)

Ord. No. (Type)	Cross section (mm ²)	Bolt	Pkg. (pcs.)	Dimensions (mm)								
				H	D	d	E	F	a	b	l	L
500052 (K150/8)	150	M8	50	8,5	21,0	16,5	12,0	11,0	28,0	31,0	58,0	69,0
500053 (K150/10)		M10		10,5			13,0	12,0			59,0	71,0
500054 (K150/12)		M12		13,0			15,0	13,0			61,0	74,0
500055 (K150/16)		M16		17,0			17,0	15,0			63,0	78,0
500056 (K185/10)		M10		10,5			24,0	19,0			14,0	14,0
500057 (K185/12)	M12	13,0	16,0	15,0	67,0	82,0						
500058 (K185/16)	M16	17,0	18,0	16,0	69,0	85,0						
500059 (K185/20)	M20	21,0	20,0	17,0	71,0	88,0						
500060 (K240/10)	M10	10,5	26	21,0	15,0	15,0			35,0	38,0	73,0	88,0
500061 (K240/12)	M12	13,0			17,0	16,0	75,0	91,0				
500062 (K240/14)	M14	15,0			18,0	17,0	76,0	93,0				
500063 (K240/16)	M16	17,0			20,0	18,0	78,0	96,0				
500064 (K240/20)	M20	21,0			22,0	20,0	80,0	100,0				
500066 (K300/12)	300	M12	25	30,0	24,0	21,0	18,0	47,0	46,0	94,0	112,0	
500067 (K300/16)		M16				21,0	18,0			94,0	112,0	
500068 (K400/12)	400	M12	25	34	27,5	21,0	18,0	51,0	48,0	98,0	116,0	
500069 (K400/16)		M16				21,0	18,0			98,0	116,0	
500070 (K400/20)		M20				21,0	18,0			98,0	116,0	

Crimping pliers

- Crimping pliers 500080 with rotating jaws for Cu lightened-lugs 6 - 50 mm².
- Crimping pliers 500081 with rotating jaws for Cu lightened-lugs 10 - 150 mm².



500080



500081

Ord. No. (Type)	Cross section (mm ²)	Length (mm)	Weight (kg)	Pkg. (pcs.)
500080 (LK 6/50)	6 - 50	390	1,7	1
500081 (LK 10/150)	10 - 150	620	4,2	1

Cable connectors

- Application: for flexible Cu conductors

Material: Copper
Surface treatment: Tinning



500090

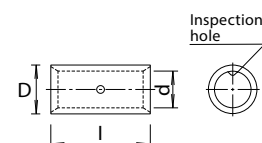

Obj. č.	Cross section (mm ²)	Pkg. (pcs.)	Dimensions (mm)		
			D	d	l
500090 (LKS-1,5)	1,5	100	3,3	1,8	25
500091 (LKS-2,5)	2,5		4,2	2,3	25
500092 (LKS-4)	4		5,0	3,0	25
500093 (LKS-6)	6		6,5	3,5	25
500094 (LKS-10)	10		7,0	4,5	30
500095 (LKS-16)	16	100	8,5	5,5	35
500096 (LKS-25)	25		10,0	7,0	40
500097 (LKS-35)	35		12,0	8,5	45
500098 (LKS-50)	50		14,0	10,0	50
500099 (LKS-70)	70		16,5	12,0	55
500100 (LKS-95)	95	50	18,0	13,5	60
500101 (LKS-120)	120		19,5	15,0	65
500102 (LKS-150)	150		21,0	16,5	70
500103 (LKS-185)	185		24,0	19,0	80
500104 (LKS-240)	240		26,0	21,0	90
500105 (LKS-300)	300	25	30,0	24,0	100
500106 (LKS-400)	400		34,0	27,5	110

Crimping cable lugs

- Application: for flexible Cu conductors.

Complies with standards: EN IEC 61238-1-1, 61238-1-3,
DIN 46234
Material: Copper
Surface treatment: Tinning



500650

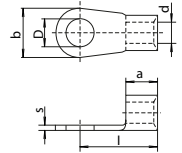

Ord. No. (Type)	Cross section (mm ²)	Bolt	Pkg. (pcs.)	Dimensions (mm)					
				d	D	b	a	l	s
500650 (7610-01/03/100)	0,5 - 1,5	M3	100	1,6	3,2	6	5	11	0,8
500651 (7610-01/3,5/100)		M3,5							
500652 (7610-01/04/100)		M4							
500653 (7610-01/05/100)		M5							
500654 (7610-03/03/100)	1,5 - 2,5	M3	100	2,3	3,2	6	5	11	0,8
500655 (7610-03/3,5/100)		M3,5							
500656 (7610-03/04/100)		M4							
500657 (7610-03/05/100)		M5							
500658 (7610-03/06/100)		M6							
500659 (7610-03/08/100)		M8							
500660 (7610-05/04/100)	4 - 6	M4	100	3,6	4,3	8	6	14	1
500661 (7610-05/05/100)		M5							
500662 (7610-05/06/100)		M6							
500663 (7610-05/08/100)		M8							
500664 (7610-05/10/100)	10	M10	100	4,5	10,5	18	8	21	1,1
500665 (7610-06/05/100)		M5							
500666 (7610-06/06/100)		M6							
500667 (7610-06/08/100)		M8							
500668 (7610-06/10/100)		M10							
500669 (7610-06/12/100)	16	M12	100	5,8	13,0	22	10	23	1,2
500700 (7610-07/06/100)		M6							
500701 (7610-07/08/100)		M8							
500702 (7610-07/10/100)		M10							
500703 (7610-07/12/100)	25	M12	50	7,5	10,5	18	11	26	1,5
500704 (7610-08/08/50)		M8							
500705 (7610-08/10/50)		M10							
500706 (7610-08/12/50)	35	M12	25	9,0	13,0	22	12	31	1,6
500707 (7610-09/08/25)		M8							
500708 (7610-09/10/25)		M10							
500709 (7610-09/12/25)	50	M12	25	11,0	10,5	18	16	34	1,8
500710 (7610-10/10/25)		M10							
500711 (7610-10/12/25)		M12							
500712 (7610-11/10/10)	70	M10	10	13,0	10,5	22	18	38	2,0
500713 (7610-11/12/10)		M12							
500714 (7610-12/10/10)	95	M10	10	15,0	13,0	24	20	42	2,5
500715 (7610-12/12/10)		M12							
500716 (7610-12/16/10)		M16							
500717 (7610-13/12/10)	120	M12	10	16,5	13,0	24	22	44	3,0
500718 (7610-13/16/10)		M16							
500719 (7610-14/12/5)	150	M12	5	19,0	13,0	30	24	50	3,2
500720 (7610-14/16/5)		M16							

TERMINAL COMPONENTS

Bolt-on cable lugs, CupAl washers, terminal pins

CONNECTING ENERGY



Bolt-on cable lugs

- Application: for rigid and flexible Cu conductors.
- Types 500120 to 500122 contain 2-screws, the other 4-screws.

Complies with standards: STN 37 1347, STN 37 1340,
EN IEC 61238-1-1, 61238-1-3
Material: Copper, steel
Surface treatment: Tinning



500120 - 500122



500123 - 500127

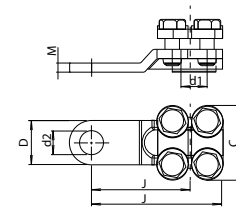

Ord. No. (Type)	Current (A)	Cross section (mm ²)	Bolt	Pkg. (pcs.)	Dimensions (mm)					
					J	C	d1	d2	D	M
500120 (7580-07)	117	16	M6	25	25	20,5	5,3	6,4	11	2,5
500121 (7580-08)	155	25	M8	20	30	25,0	6,8	8,4	15	3,0
500122 (7580-09)	192	35	M8	20	35	27,0	8,3	8,4	15	3,0
500123 (7585-10)	240	50	M10	10	45	28,0	9,4	10,5	19	3,5
500124 (7585-11)	300	70	M10	10	50	30,0	11,3	10,5	21	4,0
500125 (7585-12)	365	95	M12	5	57	32,0	13,4	13,0	24	5,0
500126 (7585-13)	425	120	M12	5	60	40,0	14,8	13,0	24	5,0
500127 (7585-14)	480	150	M16	5	65	42,0	16,3	17,0	30	5,0

CupAl washers

- Serves as intermediary segment in the connection of terminal components (Cu+Al) made from different materials.

Material: Copper, aluminium



500141

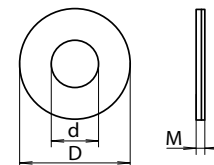
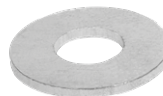

Ord. No. (Type)	Outer diameter D (mm)	Internal diameter d (mm)	Thickness M (mm)	Pkg. (pcs.)
500141 (7373-03/100)	10,5	4,0	1	100
500142 (7373-05/100)	12,5	5,0	1	100
500143 (7373-07/100)	14,0	6,0	1	100
500144 (7373-08/100)	16,0	7,5	1	100
500145 (7373-09/100)	17,0	8,0	2	100
500146 (7373-12/50)	23,0	11,0	2	50
500147 (7373-14/25)	28,0	13,0	2	25
500148 (7373-16/25)	35,0	17,0	2	25
500149 (7373-18/25)	47,0	23,0	2	25

Terminal pins

- Application: for flexible Cu conductors.

Complies with standards: DIN 46230
Material: Copper
Surface treatment: Tinning



500802

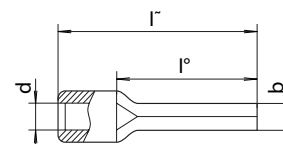

Ord. No. (Type)	Cross section (mm ²)	Pkg. (pcs.)	Dimensions (mm)			
			d	b	l1	l2
500800 (7400-01/100)	0,5 - 1,5	100	1,6	1,9	12,0	17,0
500801 (7400-03/100)	1,5 - 2,5		2,3	1,9	12,0	17,0
500802 (7400-05/100)	4 - 6	100	3,6	2,7	14,0	20,0
500803 (7400-06/100)	10		4,8	4,3	14,5	23,5
500804 (7400-07/100)	16	100	5,9	5,5	18,0	28,0

Cable connectors insulated

- Application: for flexible Cu conductors.

Complies with standards: EN IEC 61238-1-1
Material: Copper
Surface treatment: Tinning
PVC insul. temp. stability: -10 °C to +75 °C

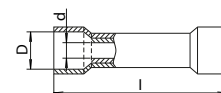
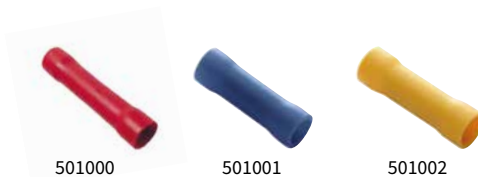

Ord. No. (Type)	Insulation colour	Cross section (mm ²)	Pkg. (pcs.)	Dimensions (mm)		
				D	d	l
501000 (LKS-1,5 IZR)	red	0,5 - 1,5	100	4,1	1,7	26
501001 (LKS-2,5 IZB)	blue	1,5 - 2,5		4,5	2,3	26
501002 (LKS-6 IZG)	yellow	4 - 6		6,5	3,6	26

Flat female terminals insulated

- Application: for flexible Cu conductors.
- Flat female terminals are designed with an extra metal ring under the insulation (double crimp).
- Terminal components specially finished surface for the lowest transient resistances and the maximum protection against corrosion.

Complies with standards: EN IEC 61238-1-1 DIN 46245
Material: Copper
Surface treatment: Tinning
PVC insul. temp. stability: -10 °C to +75 °C

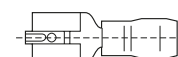
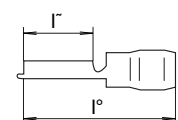

Ord. No. (Type)	Insulation colour	Cross section (mm ²)	Nominal size (mm)	Pkg. (pcs.)	Dimensions (mm)	
					l1	l2
501010 (7305-12FR)	red	0,5 - 1,5	2,8 x 0,5	100	19,8	8,0
501011 (7308-12FR)			2,8 x 0,8		19,8	8,0
501012 (7405-12FR)			4,8 x 0,5		19,8	6,0
501013 (7408-12FR)			4,8 x 0,8		19,0	6,0
501014 (7608-12FR)			6,3 x 0,8		22,4	6,0
501015 (7305-13FB)	blue	1,5 - 2,5	2,8 x 0,5	100	18,3	6,4
501016 (7308-13FB)			2,8 x 0,8		18,3	6,4
501017 (7405-13FB)			4,8 x 0,5		19,5	6,4
501018 (7408-13FB)			4,8 x 0,8		19,5	6,4
501019 (7608-13FB)			6,3 x 0,8		22,8	7,5
501020 (7608-15FG)	yellow	4 - 6	6,3 x 0,8	100	25,2	7,9
501021 (7912-15FG)			9,5 x 1,2		29,0	12,0

Flat female terminals fully insulated

- Application: for flexible Cu conductors.
- Flat female terminals are designed with an extra metal ring under the insulation (double crimp).
- Terminal components specially finished surface for the lowest transient resistances and the maximum protection against corrosion.

Complies with standards: EN IEC 61238-1-1
Material: Copper
Surface treatment: Tinning
PVC insul. temp. stability: -10 °C to +75 °C

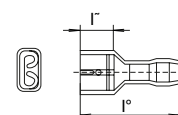
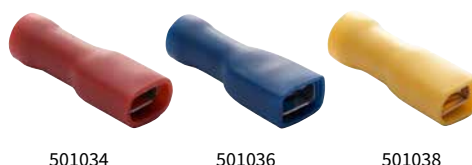

Ord. No. (Type)	Insulation colour	Cross section (mm ²)	Nominal size (mm)	Pkg. (pcs.)	Dimensions (mm)	
					l1	l2
501030 (7305P-12FR)	red	0,5 - 1,5	2,8 x 0,5	100	20,0	8,0
501031 (7308P-12FR)			2,8 x 0,8		20,0	8,0
501032 (7405P-12FR)			4,8 x 0,5		20,2	8,0
501033 (7408P-12FR)			4,8 x 0,8		20,2	8,0
501034 (7608P-12FR)			6,3 x 0,8		22,7	9,0
501035 (7405P-13FB)	blue	1,5 - 2,5	4,8 x 0,5	100	20,5	7,5
501036 (7408P-13FB)			4,8 x 0,8		20,5	7,5
501037 (7608P-13FB)			6,3 x 0,8		22,8	9,2
501038 (7608P-15FG)	yellow	4 - 6	6,3 x 0,8	100	25,6	8,5

Flat male terminals insulated

- Application: for flexible Cu conductors.
- Flat male terminals are designed with an extra metal ring under the insulation (double crimp).
- Terminal components specially finished surface for the lowest transient resistances and the maximum protection against corrosion.

Complies with standards: EN IEC 61238-1-1 DIN 46245
Material: Copper
Surface treatment: Tinning
PVC insul. temp. stability: -10 °C to +75 °C



501054

501057

501058

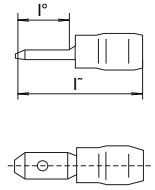

Ord. No. (Type)	Insulation colour	Cross section (mm ²)	Nominal size (mm)	Pkg. (pcs.)	Dimensions (mm)	
					l1	l2
501050 (7305-12MR)	red	0,5 - 1,5	2,8 x 0,5	100	17,5	7,5
501051 (7308-12MR)			2,8 x 0,8		17,5	7,5
501052 (7405-12MR)			4,8 x 0,5		18,5	7,5
501053 (7408-12MR)			4,8 x 0,8		19,0	8,0
501054 (7608-12MR)			6,3 x 0,8		21,5	8,5
501055 (7405-13MB)	blue	1,5 - 2,5	4,8 x 0,5	100	19,0	6,5
501056 (7408-13MB)			4,8 x 0,8		19,0	6,5
501057 (7608-13MB)			6,3 x 0,8		21,8	8,5
501058 (7608-15MG)	yellow	4 - 6	6,3 x 0,8	100	25,2	8,5

Flat female/male terminals insulated

- Application: for flexible Cu conductors.
- Flat female terminals are designed with an extra metal ring under the insulation (double crimp).
- Terminal components specially finished surface for the lowest transient resistances and the maximum protection against corrosion.

Complies with standards: EN IEC 61238-1-1
Material: Copper
Surface treatment: Tinning
PVC insul. temp. stability: -10 °C to +75 °C



501070

501071

501072

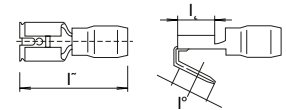

Ord. No. (Type)	Insulation colour	Cross section (mm ²)	Nominal size (mm)	Pkg. (pcs.)	Dimensions (mm)		
					l1	l2	l3
501070 (7608-12FMR)	red	0,5 - 1,5	6,3 x 0,8	100	22,2	7,5	8,0
501071 (7608-13FMB)	blue	1,5 - 2,5			22,6		
501072 (7608-15FMG)	yellow	4 - 6			27,0		

Insulated fork terminals

- Application: for flexible Cu conductors.

Complies with standards: EN IEC 61238-1-1 DIN 46237
Material: Copper
Surface treatment: Tinning
PVC insul. temp. stability: -10 °C to +75 °C



501085

501093

501100

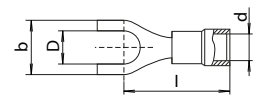

Ord. No. (Type)	Insulation colour	Cross section (mm ²)	Bolt	Pkg. (pcs.)	Dimensions (mm)			
					d	D	b	l
501080 (7612-12/U 3FR)	red	0,5 - 1,5	M3	100	4,1	3,2	5,0	15,5
501081 (7612-12/U 3,5FR)			M3,5			3,7	5,8	16,5
501082 (7612-12/U 4FR)			M4			4,3	6,4	17,5
501083 (7612-12/U 5FR)			M5			5,3	8,0	17,5
501084 (7612-12/U 6FR)			M6			6,4	9,4	18,5
501085 (7612-12/U 8FR)			M8			8,4	12,0	20,0
501086 (7612-12/U 10FR)			M10			10,5	17,5	22,5
501088 (7612-13/U 3FB)	blue	1,5 - 2,5	M3	100	4,5	3,2	5,0	15,5
501089 (7612-13/U 3,5FB)			M3,5			3,7	5,8	16,5
501090 (7612-13/U 4FB)			M4			4,3	6,4	17,5
501091 (7612-13/U 5FB)			M5			5,3	8,5	20,0
501092 (7612-13/U 6FB)			M6			6,4	9,5	18,0
501093 (7612-13/U 8FB)			M8			8,4	12,0	20,0
501096 (7612-15/U 3,5FG)	yellow	4 - 6	M3,5	100	6,5	3,7	7,2	22,5
501097 (7612-15/U 4FG)			M4			4,3	8,5	22,0
501098 (7612-15/U 5FG)			M5			5,3	9,5	22,0
501099 (7612-15/U 6FG)			M6			6,5	9,5	25,0
501100 (7612-15/U 8FG)			M8			8,4	13,5	26,0

Insulated cable lugs

- Application: for flexible Cu conductors.

Complies with standards: EN IEC 61238-1-1 DIN 46237
Material: Copper
Surface treatment: Tinning
PVC insul. temp. stability: -10 °C to +75 °C

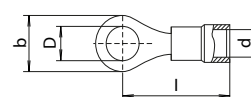

Ord. No. (Type)	Insulation colour	Cross section (mm ²)	Bolt	Pkg. (pcs.)	Dimensions (mm)							
					d	D	b	l				
501111 (7610-12/M 3FR)	red	0,5 - 1,5	M3	100	4,1	3,2	5,6	14,5				
501112 (7610-12/M 3,5FR)			M3,5			3,7	6,6	14,5				
501113 (7610-12/M 4FR)			M4			4,3	6,6	16,5				
501114 (7610-12/M 5FR)			M5			5,3	8,0	18,0				
501115 (7610-12/M 6FR)			M6			6,4	11,6	18,0				
501116 (7610-12/M 8FR)			M8			8,4	11,6	22,0				
501117 (7610-12/M 10FR)			M10			10,5	13,6	24,0				
501118 (7610-12/M 12FR)			M12			13,0	19,2	25,5				
501120 (7610-13/M 3FB)			blue			1,5 - 2,5	M3	100	4,5	3,2	6,4	17,0
501121 (7610-13/M 3,5FB)							M3,5			3,7	6,4	17,0
501122 (7610-13/M 4FB)	M4	4,3		8,5	16,5							
501123 (7610-13/M 5FB)	M5	5,3		8,5	20,0							
501124 (7610-13/M 6FB)	M6	6,4		12,0	18,5							
501125 (7610-13/M 8FB)	M8	8,4		12,0	23,0							
501126 (7610-13/M 10FB)	M10	10,5		13,6	25,5							
501127 (7610-13/M 12FB)	M12	13,0		19,2	24,0							
501128 (7610-15/M 3FG)	yellow	4 - 6	M3	100	6,5	3,2	7,2	22,0				
501129 (7610-15/M 3,5FG)			M3,5			3,7	8,0	22,0				
501130 (7610-15/M 4FG)			M4			4,3	9,5	22,0				
501131 (7610-15/M 5FG)			M5			5,3	9,5	22,0				
501132 (7610-15/M 6FG)			M6			6,4	12,0	25,0				
501133 (7610-15/M 8FG)			M8			8,4	15,0	26,0				
501134 (7610-15/M 10FG)			M10			10,5	15,0	27,0				
501135 (7610-15/M 12FG)			M12			13,0	19,2	27,0				

Insulated cable sleeves

- Application: for flexible Cu conductors.

Complies with standards: EN IEC 61238-1-1, DIN 46228
Material: Copper
Surface treatment: Tinning
PVC or PP insul. temp. stability: -20 °C to +105 °C

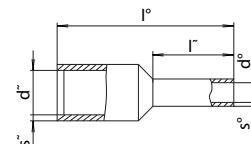

Ord. No. (Type)	Insulation colour	Cross section (mm ²)	Pkg. (pcs.)	Dimensions (mm)					
				l1	l2	d1	d2	s1	s2
501150 (DI 0,14/6)	grey	0,14	100	10,4	6	0,7	1,6	0,12	0,20
501151 (DI 0,25/6)	light blue	0,25	100	10,5	6	0,75	2,0	0,25	0,25
501152 (DI 0,25/8)				12,5	8	0,75			
501153 (DI 0,34/6)	turquoise	0,34	100	10,5	6	0,75	2,0	0,25	0,25
501154 (DI 0,34/8)				12,5	8	0,75			
501155 (DI 0,5/6)	orange	0,5	100	12	6	1,0	2,6	0,15	0,25
501156 (DI 0,5/8)				14	8	1,0			
501157 (DI 0,5/10)				16	10	1,0			
501158 (DI 0,75/6)				12	6	1,2			
501159 (DI 0,75/8)	white	0,75	100	14	8	1,2	2,8	0,15	0,25
501160 (DI 0,75/10)				16	10	1,2			
501161 (DI 0,75/12)				18	12	1,2			
501162 (DI 1/6)	yellow	1	100	12	6	1,4	3,0	0,15	0,25
501163 (DI 1/8)				14	8	1,4			
501164 (DI 1/10)				16	10	1,4			
501165 (DI 1/12)				18	12	1,4			
501166 (DI 1,5/8)	red	1,5	100	14	8	1,7	3,5	0,15	0,25
501167 (DI 1,5/10)				16	10	1,7			
501168 (DI 1,5/12)				18	12	1,7			
501169 (DI 1,5/18)				24	18	1,7			
501170 (DI 2,5/8)	blue	2,5	100	14	8	2,2	4,2	0,15	0,25
501171 (DI 2,5/12)				18	12	2,2			
501172 (DI 2,5/18)				24	18	2,2			
501173 (DI 4/10)	grey	4	100	17	17	10,0	4,8	0,2	0,3
501174 (DI 4/12)				20	20	12,0			
501175 (DI 4/18)				26	26	18,0			

Insulated cable sleeves

(continuing)

Ord. No. (Type)	Insulation colour	Cross section (mm ²)	Pkg. (pcs.)	Dimensions (mm)					
				l1	l2	d1	d2	s1	s2
501176 (DI 6/12)	black	6	100	20	20	12,0	6,3	0,2	0,3
501177 (DI 6/18)				26	26	18,0			
501178 (DI 10/12)				22	22	12,0			
501179 (DI 10/18)	ivory	10	100	28	28	18,0	7,6	0,2	0,4
501180 (DI 16/12)				24	24	12,0			
501181 (DI 16/18)				28	28	18,0			
501182 (DI 25/16)	green	16	100	29	29	16,0	11,2	0,2	0,4
501183 (DI 25/22)				36	36	22,0			
501184 (DI 35/16)				30	30	16,0			
501185 (DI 35/25)	beige	35	100	39	39	25,0	12,7	0,2	0,4
501186 (DI 50/20)				36	36	20,0			
501187 (DI 50/25)				40	40	25,0			
501188 (DI 70/20)	yellow	70	100	37	37	20,0	16,0	0,40	0,60
501189 (DI 95/25)				44	44	25,0			
501190 (DI 120/27)				48	48	27,0			
501191 (DI 150/32)	blue	120	100	58	58	32,0	23,0	0,50	1,00
	yellow	150	100						

Insulated twin cable sleeves

• Application: for flexible Cu conductors.

Complies with standards: EN IEC 61238-1-1, DIN 46228
Material: Copper
Surface treatment: Tinning
PVC or PP insul. temp. stability: -20 °C to +105 °C

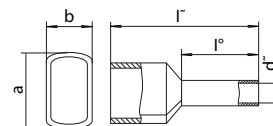

Ord. No. (Type)	Insulation colour	Cross section (mm ²)	Pkg. (pcs.)	Dimensions (mm)				
				l1	l2	d1	a	b
501210 (DID 0,5/8)	orange	2 x 0,5	100	15	8	1,5	4,5	2,3
501211 (DID 0,5/10)				17	10			
501212 (DID 0,75/8)				15	8			
501213 (DID 0,75/10)	white	2 x 0,75	100	15	10	1,8	5,1	2,6
501214 (DID 1/8)				15	8			
501215 (DID 1/10)				17	10			
501216 (DID 1,5/8)	yellow	2 x 1,0	100	16	8	2,05	5,1	3,0
501217 (DID 1,5/12)				20	12			
501218 (DID 2,5/10)				18,5	10			
501219 (DID 2,5/13)	red	2 x 1,5	100	21,5	13	2,9	7,5	4,0
501220 (DID 4/12)				23	12			
501221 (DID 4/18)				29	18			
501222 (DID 6/14)	blue	2 x 2,5	100	25	14	4,6	9,6	5,8
501223 (DID 6/18)				29	18			
501224 (DID 10/14)				26	14			
501225 (DID 16/16)	grey	2 x 4	100	31	16	8,5	16,6	8,8
	black	2 x 6	100					
	ivory	2 x 10	100					
	green	2 x 16	50					

Insulated pin terminals

• Application: for flexible Cu conductors.

Complies with standards: EN IEC 61238-1-1, DIN 46231
Material: Copper
Surface treatment: Tinning
PVC insul. temp. stability: -10 °C to +75 °C

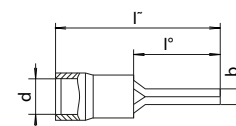

Ord. No. (Type)	Insulation colour	Cross section (mm ²)	Pkg. (pcs.)	Dimensions (mm)			
				d	b	l1	l2
501240 (7400-P8 FR)	red	0,5 - 1,5	100	3,9	1,7	8	17,8
501241 (7400-P10 FR)					1,8	10	19,8
501242 (7400-P12 FR)					1,8	12	22
501243 (7400-P8 FB)	blue	1,5 - 2,5	100	4,9	1,7	8	17,8
501244 (7400-P10 FB)					1,8	10	19,8
501245 (7400-P12 FB)					1,8	12	21,8
501248 (7400-P14 FG)	yellow	4 - 6	100	6,7	2,2	14	28,6

Flat female terminals

- Terminal components specially finished surface for the lowest transient resistances and the maximum protection against corrosion.
- The recommended length of the bared end of the conductor is 6 mm for the conductors of 0,5 ÷ 2,5 mm² cross sections and 7 mm for larger cross sections.

Complies with standards: STN EN 61210, DIN 46247
Protection: IP20 with slide insulators
Material: Brass
Ambient temperature: +85 °C



500162



500163

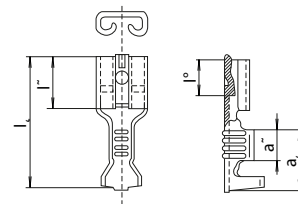

Ord. No. (Type)	Surface treatment	Current (A)	Cross section (mm ²)	Nominal size (mm)	Pkg. (pcs.)	Dimensions (mm)				
						l1	l2	l3	a1	a2
500162 (7100-01/100)	Passivation	4 - 7,5	0,5 - 1	2,8 x 0,5	100	14,5	6,2	3,3	5,5	2,5
500163 (7100-11/100)	Tinny									
500164 (7101-01/100)	Passivation	4 - 7,5	0,5 - 1	4,8 x 0,8	100	15,6	6,4	3,8	6,0	3,4
500165 (7101-11/100)	Tinny									
500168 (7102-01/100)	Passivation	4 - 7,5	0,5 - 1	6,3 x 0,8	100	19,2	7,6	4,0	8,5	4,5
500169 (7102-11/100)	Tinny									
500170 (7102-03/100)	Passivation	12 - 15	1,5 - 2,5	6,3 x 0,8	100	19,2	7,6	4,0	8,5	4,5
500171 (7102-13/100)	Tinny									
500172 (7102-05/100)	Passivation	18 - 20	4 - 6	6,3 x 0,8	100	19,2	7,6	4,0	8,5	4,5
500173 (7102-15/100)	Tinny									

ACCESSORIES

For female	Front slide terminal insulator	Ord. No. (Type)
500168 (7102-01/100)		500300 (7912-20)
500169 (7102-11/100)		
500170 (7102-03/100)		
500171 (7102-13/100)		

Single-wire slide over insulator

- Slide-over insulators are slid from the front after the flat female terminal is crimped on the conductor.
- Ord. No. 500300 – white colour/ ord. No. 500301 – grey colour.

Material: Termoplast
Ambient temperature: -25 °C to +85 °C



500300

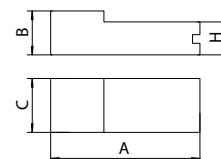

Ord. No. (Type)	Flat female	Surface treatment of female	Cross section (mm ²)	Pkg. (pcs.)	Dimensions (mm)			
					A	B	C	H
500300 (7912-20)	500168 (7102-01)	Passivation	0,5 - 1	100	25,5	6,2	9,2	4,8
	500169 (7102 -11)	Tinny						
	500170 (7102-03)	Passivation	1,5 - 2,5					
	500171 (7102 -13)	Tinny						

Flat male terminals

- Terminal components specially finished surface for the lowest transient resistances and the maximum protection against corrosion.
- The recommended length of the bared end of the conductor is 6 mm for the conductors of 1,5 ÷ 2,5 mm².

Complies with standards: STN EN 61210, DIN 46248
Protection: IP20 with slide insulators
Material: Brass
Ambient temperature: +85 °C



500190



500191

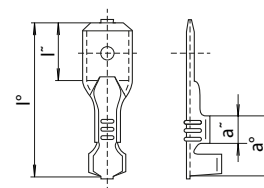

Ord. No. (Type)	Surface treatment	Current (A)	Cross section (mm ²)	Nominal size (mm)	Pkg. (pcs.)	Dimensions (mm)			
						l1	l2	a1	a2
500190 (7212-03/100)	Passivation	12 - 15	1,5 - 2,5	6,3 x 0,8	100	20	7,9	8,5	4,6
500191 (7212-13/100)	Tinny								

Flat female/male terminal

- The recommended length of the bared end of the conductor is 6 mm for the conductors of 1,5 ÷ 2,5 mm²
- Terminal components specially finished surface for the lowest transient resistances and the maximum protection against corrosion.

Complies with standards: STN EN 61210, DIN 46346
Protection: IP20 with slide insulators
Material: Brass
Surface treatment: Passivation
Ambient temperature: +85 °C



500200

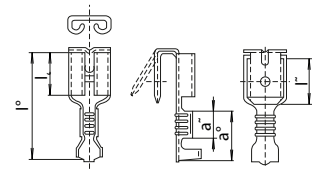

Ord. No. (Type)	Current (A)	Cross section (mm ²)	Nominal size (mm)	Pkg. (pcs.)	Dimensions (mm)				
					I1	I2	I3	a1	a2
500200 (7132-03/100)	10	1,5 – 2,5	6,3 x 0,8	100	19,2	8	7,6	8,5	4,5

Flat male terminals (panel male faston)

- Terminal components with specially finished surface for the lowest transient resistance and the maximum protection against corrosion.

Complies with standards: STN EN 61210
Material: Brass
Surface treatment: Passivation
Ambient temperature: +85 °C



500226

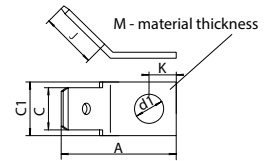

Ord. No. (Type)	Design	Number of poles	Current (A)	Nominal size (mm)	Pkg. (pcs.)	Dimensions (mm)						
						A	C1	C	J	K	d1	M
500224 (7202-00/4/100)	angled	1	20	6,3 x 0,8	100	16,0	8	6,3	8,0	4,0	M4	0,8
500226 (7202-00/5/100)						18,0	10			5,0	M5	

Flat double male terminals (panel male double faston)

- Terminal components specially finished surface for the lowest transient resistances and the maximum protection against corrosion.

Complies with standards: STN EN 61210
Material: Brass
Surface treatment: Passivation
Ambient temperature: +85 °C



500240

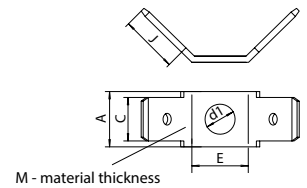

Ord. No. (Type)	Design	Number of poles	Current (A)	Nominal size (mm)	Pkg. (pcs.)	Dimensions (mm)					
						A	C	E	d1	J	M
500240 (7242-00/5/1)	angled	1	25	6,3 x 0,8	100	8,0	6,3	10	M5	8	0,8

TERMINAL COMPONENTS

Multipole flat male and female terminals, multipole plastic sockets and plugs

CONNECTING ENERGY



Female terminals

- Through a special protruded cleat which locks with insulating bodies they create one unit-Multipole insulated plug or socket.
- Terminal components specially finished surface for the lowest transient resistances and the maximum protection against corrosion.
- The recommended length of the bared end of the conductor is 6 mm for the conductors of 0,5 ÷ 2,5 mm².



500260



500261

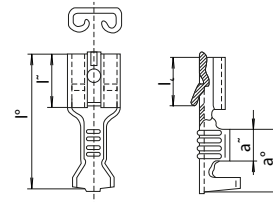

Complies with standards:	STN EN 61210, DIN 46340
Protection:	IP20 with slide insulators
Material:	Brass
Ambient temperature:	+85 °C

Ord. No. (Type)	Surface treatment	Current (A)	Cross section (mm ²)	Nominal size (mm)	Pkg. (pcs.)	Dimensions (mm)				
						l1	l2	l3	a1	a2
500260 (7122-01/100)	Passivation	4 - 7,5	0,5 - 1	6,3 x 0,8	100	19	7,4	7	8,5	4,5
500261 (7122-11/100)	Tinning									
500262 (7122-03/100)	Passivation	12 - 15	1,5 - 2,5							
500263 (7122-13/100)	Tinning									

Male terminals

- Through a special protruded cleat which locks with insulating bodies they create one unit-Multipole insulated plug or socket.
- Terminal components specially finished surface for the lowest transient resistances and the maximum protection against corrosion.
- The recommended length of the bared end of the conductor is 6 mm for the conductors of 0,5 ÷ 2,5 mm².



500280



500281

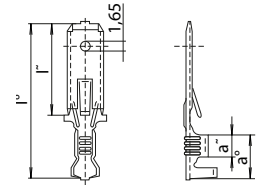

Complies with standards:	STN EN 61210, DIN 46343
Material:	Brass
Ambient temperature:	+85 °C

Ord. No. (Type)	Surface treatment	Current (A)	Cross section (mm ²)	Nominal size (mm)	Pkg. (pcs.)	Dimensions (mm)			
						l1	l2	a1	a2
500280 (7232-01/100)	Passivation	4 - 7,5	0,5 - 1	6,3 x 0,8	100	28	16	8,2	4
500281 (7232-11/100)	Tinning								
500282 (7232-03/100)	Passivation	12 - 15	1,5 - 2,5						
500283 (7232-13/100)	Tinning								

Multipole plastic sockets secured

- The design of both sockets and plugs prevents them from twisting and wrong insertion of socket into plug.
- The terminals are inserted into the insulation bodies after they have been pressed on the conductor.



500441

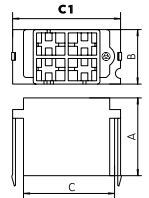

Material:	Thermoplast
Ambient temperature:	-25 °C to +85 °C

Ord. No. (Type)	Number of poles	Nominal size (mm)	Pkg. (pcs.)	Dimensions (mm)			
				A	B	C	C1
500440 (7942-10)	4	6,3 x 0,8	100	25,0	17,0	23,4	34,7
500441 (7962-10)	6			24,5	16,3	28,6	38,0
500442 (7982-10)	8					37,8	47,3

Multipole plastic plugs secured

- The design of both sockets and plugs prevents them from twisting and wrong insertion of socket into plug.
- The terminals are inserted into the insulation bodies after they have been pressed on the conductor.



500461

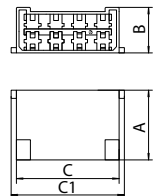

Material:	Thermoplast
Ambient temperature:	-25 °C to +85 °C

Ord. No. (Type)	Number of poles	Nominal size (mm)	Pkg. (pcs.)	Dimensions (mm)			
				A	B	C	C1
500460 (7042-10)	4	6,3 x 0,8	100	32,5	17,2	27,5	37,2
500461 (7062-10)	6				18,0	31,4	40,5
500462 (7082-10)	8					40,6	49,8

Plastic sockets combined

- The design of both sockets and plugs prevents them from twisting and wrong insertion of socket into plug.
- The terminals are inserted into the insulation bodies after they have been pressed on the conductor.



500480

Material: Thermoplast
Ambient temperature: -25 °C to +85 °C

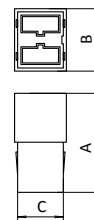

Ord. No. (Type)	Number of poles	Nominal size (mm)	Pkg. (pcs.)	Dimensions (mm)		
				A	B	C
500480 (7922-00)	2	6,3 x 0,8	100	22,9	15	12,2

Plastic plugs combined

- The design of both sockets and plugs prevents them from twisting and wrong insertion of socket into plug.
- The terminals are inserted into the insulation bodies after they have been pressed on the conductor.



500500

Material: Thermoplast
Ambient temperature: -25 °C to +85 °C

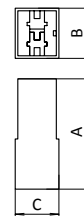

Ord. No. (Type)	Number of poles	Nominal size (mm)	Pkg. (pcs.)	Dimensions (mm)		
				A	B	C
500500 (7022-00)	2	6,3 x 0,8	100	32	15,5	13,5

Register

Ord. No.	page	100610 (IVGN 12531)	18	101171 (ISGN 6341)	22	101634 (IZG 1653)	26
100000 (IVN 1631)	14	100611 (IVGN 12541)	18	101172 (ISGN 6351)	22	101635 (IZG 3233)	26
100001 (IVN 1641)	14	100612 (IVGN 12551)	18	101173 (ISGN 6332)	22	101636 (IZG 3243)	26
100002 (IVN 1651)	14	100613 (IVGN 12532)	18	101177 (ISG 6343)	22	101637 (IZG 3253)	26
100003 (IVN 3231)	14	100617 (IVGN 12543)	18	101178 (ISGN 6353)	22	101638 (IZG 1635)	26
100004 (IVN 3241)	14	100618 (IVGN 12553)	18	101180 (ISG 6345)	22	101639 (IZG 1645)	26
100005 (IVN 3251)	14	100620 (IVGN 12545)	18	101250 (ISGN 12531)	24	101640 (IZG 1655)	26
100006 (IVN 1632)	14	100621 (IVGN 12555)	18	101251 (ISGN 12541)	24	101641 (IZG 3235)	26
100007 (IVN 1642)	14	100696 (PVG 16)	18	101252 (ISGN 12551)	24	101642 (IZG 3245)	26
100008 (IVN 1652)	14	100697 (PSG 16)	18	101253 (ISGN 12531-p)	24	101643 (IZG 3255)	26
100009 (IVN 3232)	14	100698 (PSG 16/S)	18	101254 (ISGN 12541-p)	24	101710 (IZG 1631 L)	28
100010 (IVN 3242)	14	100730 (ISN 1631)	20	101255 (ISGN 12551-p)	24	101713 (IZG 3231 L)	28
100011 (IVN 3252)	14	100731 (ISN 1641)	20	101259 (ISGN 12532)	24	101716 (IZG 1632 L)	28
100013 (IVN 1643)	14	100732 (ISN 1651)	20	101262 (ISGN 12532-p)	24	101717 (IZG 1642 L)	28
100018 (IVN 1635)	14	100733 (ISN 3231)	20	101269 (ISGN 12543)	24	101719 (IZG 3232 L)	28
100014 (IVN 1653)	14	100734 (ISN 3241)	20	101270 (ISGN 12553)	24	101720 (IZG 3242 L)	28
100016 (IVN 3243)	14	100735 (ISN 3251)	20	101272 (ISGN 12543-p)	24	101723 (IZG 1643 L)	28
100017 (IVN 3253)	14	100736 (ISN 1632)	20	101273 (ISGN 12553-p)	24	101724 (IZG 1653 L)	28
100019 (IVN 1645)	14	100737 (ISN 1642)	20	101278 (ISGN 12545)	24	101726 (IZG 3243 L)	28
100020 (IVN 1655)	14	100738 (ISN 1652)	20	101279 (ISGN 12555)	24	101727 (IZG 3253 L)	28
100021 (IVN 3235)	14	100739 (ISN 3232)	20	101281 (ISGN 12545-p)	24	101800 (IZGB 1631)	28
100022 (IVN 3245)	14	100740 (ISN 3242)	20	101282 (ISGN 12555-p)	24	101801 (IZGB 1641)	28
100023 (IVN 3255)	14	100741 (ISN 3252)	20	101350 (IZN 1631)	24	101802 (IZGB 1651)	28
100090 (IVB 1631)	14	100743 (ISN 1643)	20	101351 (IZN 1641)	24	101803 (IZGB 3231)	28
100091 (IVB 1641)	14	100744 (ISN 1653)	20	101352 (IZN 1651)	24	101804 (IZGB 3241)	28
100092 (IVB 1651)	14	100746 (ISN 3243)	20	101353 (IZN 3231)	24	101805 (IZGB 3251)	28
100093 (IVB 3231)	14	100747 (ISN 3253)	20	101354 (IZN 3241)	24	101806 (IZGB 1632)	28
100094 (IVB 3241)	14	100748 (ISN 1635)	20	101355 (IZN 3251)	24	101807 (IZGB 1642)	28
100095 (IVB 3251)	14	100749 (ISN 1645)	20	101356 (IZN 1632)	24	101808 (IZGB 1652)	28
100096 (IVB 1632)	14	100750 (ISN 1655)	20	101357 (IZN 1642)	24	101809 (IZGB 3232)	28
100097 (IVB 1642)	14	100751 (ISN 3235)	20	101358 (IZN 1652)	24	101810 (IZGB 3242)	28
100098 (IVB 1652)	14	100752 (ISN 3245)	20	101359 (IZN 3232)	24	101811 (IZGB 3252)	28
100099 (IVB 3232)	14	100753 (ISN 3255)	20	101360 (IZN 3242)	24	101813 (IZGB 1643)	28
100100 (IVB 3242)	14	100823 (ISN 6332)	20	101361 (IZN 3252)	24	101814 (IZGB 1653)	28
100101 (IVB 3252)	14	100827 (IS 6343)	20	101362 (IZN 1633)	24	101816 (IZGB 3243)	28
100103 (IVB 1643)	14	100828 (ISN 6353)	20	101363 (IZN 1643)	24	101817 (IZGB 3253)	28
100104 (IVB 1653)	14	100830 (IS 6345)	20	101364 (IZN 1653)	24	101897 (IZG 6343)	28
100106 (IVB 3243)	14	100900 (ISB 1631)	20	101365 (IZN 3233)	24	101898 (IZGN 6353)	28
100107 (IVB 3253)	14	100901 (ISB 1641)	20	101366 (IZN 3243)	24	101900 (IZG 6345)	28
100193 (IVNO 1643)	14	100902 (ISB 1651)	20	101367 (IZN 3253)	24	101970 (IZGN 6331 L)	30
100194 (IVNO 1653)	14	100903 (ISB 3231)	20	101368 (IZN 1635)	24	101971 (IZGN 6341)	30
100196 (IVNO 3243)	14	100904 (ISB 3241)	20	101369 (IZN 1645)	24	101972 (IZGN 6351 L)	30
100197 (IVNO 3253)	14	100905 (ISB 3251)	20	101370 (IZN 1655)	24	101973 (IZGN 6332 L)	30
100273 (IVN 6332)	16	100906 (ISB 1632)	20	101371 (IZN 3235)	24	101977 (IZGN 6343 L)	30
100277 (IV 6343)	16	100907 (ISB 1642)	20	101372 (IZN 3245)	24	101978 (IZGN 6353 L)	30
100278 (IVN 6353)	16	100908 (ISB 1652)	20	101373 (IZN 3255)	24	102050 (IZGN 12531)	30
100280 (IV 6345)	16	100909 (ISB 3232)	20	101440 (IZN 1631 L)	24	102051 (IZGN 12541)	30
100350 (IVG 1631)	16	100910 (ISB 3242)	20	101443 (IZN 3231 L)	24	102052 (IZGN 12551)	30
100351 (IVG 1641)	16	100911 (ISB 3252)	20	101446 (IZN 1632 L)	24	102053 (IZGN 12531-p)	30
100352 (IVG 1651)	16	100913 (ISB 1643)	20	101447 (IZN 1642 L)	24	102054 (IZGN 12541-p)	30
100353 (IVG 3231)	16	100914 (ISB 1653)	20	101448 (IZN 1652 L)	24	102055 (IZGN 12551-p)	30
100354 (IVG 3241)	16	100916 (ISB 3243)	20	101449 (IZN 3232 L)	24	102059 (IZGN 12532)	30
100355 (IVG 3251)	16	100917 (ISB 3253)	20	101450 (IZN 3242 L)	24	102062 (IZGN 12532-p)	30
100356 (IVG 1632)	16	100990 (ISG 1631)	22	101451 (IZN 3252 L)	24	102069 (IZGN 12543)	30
100357 (IVG 1642)	16	100991 (ISG 1641)	22	101453 (IZN 1643 L)	24	102070 (IZGN 12553)	30
100359 (IVG 3232)	16	100992 (ISG 1651)	22	101454 (IZN 1653 L)	24	102072 (IZGN 12543-p)	30
100360 (IVG 3242)	16	100993 (ISG 3231)	22	101456 (IZN 3243 L)	24	102073 (IZGN 12553-p)	30
100363 (IVG 1643)	16	100994 (ISG 3241)	22	101457 (IZN 3253 L)	24	102078 (IZGN 12545)	30
100364 (IVG 1653)	16	100995 (ISG 3251)	22	101473 (IZN 6332)	26	102079 (IZGN 12555)	30
100366 (IVG 3243)	16	100996 (ISG 1632)	22	101477 (IZ 6343)	26	102081 (IZGN 12545-p)	30
100367 (IVG 3253)	16	100997 (ISG 1642)	22	101478 (IZN 6353)	26	102082 (IZGN 12555-p)	30
100368 (IVG 1635)	16	100999 (ISG 3232)	22	101480 (IZ 6345)	26	102150 (IZV 1632)	30
100369 (IVG 1645)	16	101000 (ISG 3242)	22	101530 (IZB 1631)	26	102153 (IZV 3232)	30
100370 (IVG 1655)	16	101003 (ISG 1643)	22	101531 (IZB 1641)	26	102157 (IZV 1643)	30
100371 (IVG 3235)	16	101004 (ISG 1653)	22	101532 (IZB 1651)	26	102158 (IZV 1653)	30
100372 (IVG 3245)	16	101006 (ISG 3243)	22	101533 (IZB 3231)	26	102160 (IZV 3243)	30
100373 (IVG 3255)	16	101007 (ISG 3253)	22	101534 (IZB 3241)	26	102161 (IZV 3253)	30
100450 (IVGB 1631)	16	101008 (ISG 1635)	22	101535 (IZB 3251)	26	102200 (IZVZ-S 1632)	32
100451 (IVGB 1641)	16	101009 (ISG 1645)	22	101536 (IZB 1632)	26	102203 (IZVZ-S 3232)	32
100452 (IVGB 1651)	16	101010 (ISG 1655)	22	101537 (IZB 1642)	26	102207 (IZVZ-S 1643)	32
100453 (IVGB 3231)	16	101011 (ISG 3235)	22	101538 (IZB 1652)	26	102208 (IZVZ-S 1653)	32
100454 (IVGB 3241)	16	101012 (ISG 3245)	22	101539 (IZB 3232)	26	102210 (IZVZ-S 3243)	32
100455 (IVGB 3251)	16	101013 (ISG 3255)	22	101540 (IZB 3242)	26	102211 (IZVZ-S 3253)	32
100456 (IVGB 1632)	16	101080 (ISGB 1631)	22	101541 (IZB 3252)	26	102257 (IZV 16)	32
100457 (IVGB 1642)	16	101081 (ISGB 1641)	22	101543 (IZB 1643)	26	102258 (IZV 16S)	32
100458 (IVGB 1652)	16	101082 (ISGB 1651)	22	101544 (IZB 1653)	26	102262 (IZV 3232)	32
100459 (IVGB 3232)	16	101083 (ISGB 3231)	22	101546 (IZB 3243)	26	102267 (IZV 1643)	32
100460 (IVGB 3242)	16	101084 (ISGB 3241)	22	101547 (IZB 3253)	26	102268 (IZV 1653)	32
100461 (IVGB 3252)	16	101085 (ISGB 3251)	22	101620 (IZG 1631)	26	102270 (IZV 3243)	32
100463 (IVGB 1643)	16	101086 (ISGB 1632)	22	101621 (IZG 1641)	26	102271 (IZV 3253)	32
100464 (IVGB 1653)	16	101087 (ISGB 1642)	22	101622 (IZG 1651)	26	102347 (IZVN 16)	32
100466 (IVGB 3243)	16	101088 (ISGB 1652)	22	101623 (IZG 3231)	26	102348 (IZVN 16S)	32
100467 (IVGB 3253)	16	101089 (ISGB 3232)	22	101624 (IZG 3241)	26	102352 (IZVN 3232)	32
100530 (IVGN 6331)	18	101090 (ISGB 3242)	22	101625 (IZG 3251)	26	102357 (IZVN 1643)	32
100531 (IVGN 6341)	18	101091 (ISGB 3252)	22	101626 (IZG 1632)	26	102358 (IZVN 1653)	32
100532 (IVGN 6351)	18	101093 (ISGB 1643)	22	101627 (IZG 1642)	26	102360 (IZVN 3243)	32
100533 (IVGN 6332)	18	101094 (ISGB 1653)	22	101629 (IZG 3232)	26	102361 (IZVN 3253)	32
100537 (IVG 6343)	18	101096 (ISGB 3243)	22	101630 (IZG 3242)	26	102430 (IPN 1631)	34
100538 (IVGN 6353)	18	101097 (ISGB 3253)	22	101632 (IZG 1633)	26	102431 (IPN 1641)	34
100540 (IVG 6345)	18	101170 (ISGN 6331)	22	101633 (IZG 1643)	26	102432 (IPN 1651)	34

102433 (IPN 3231)	34	103135 (IEB 3251)	40	103790 (VZG 16)	44	104541 (IRRGN 12541)	52
102434 (IPN 3241)	34	103136 (IEB 1632)	40	103791 (VZG 16C)	44	104542 (IRRGN 12551)	52
102435 (IPN 3251)	34	103137 (IEB 1642)	40	103792 (VZG 16S)	44	104543 (IRRGN 12532)	52
102436 (IPN 1632)	34	103138 (IEB 1652)	40	103830 (VZ 48)	46	104547 (IRRGN 12543)	52
102439 (IPN 3232)	34	103139 (IEB 3232)	40	103846 (IR 1632)	46	104548 (IRRGN 12553)	52
102443 (IPN 1643)	34	103140 (IEB 3242)	40	103849 (IR 3232)	46	104550 (IRRGN 12545)	52
102444 (IPN 1653)	34	103141 (IEB 3252)	40	103853 (IR 1643)	46	104551 (IRRGN 12555)	52
102446 (IPN 3243)	34	103143 (IEB 1643)	40	103854 (IR 1653)	46	104634 (A 1653/43)	52
102447 (IPN 3253)	34	103144 (IEB 1653)	40	103856 (IR 3243)	46	104637 (A 3253/43)	52
102448 (IPN 1635)	34	103146 (IEB 3243)	40	103857 (IR 3253)	46	104693 (A 16-32/4)	54
102449 (IPN 1645)	34	103147 (IEB 3253)	40	103936 (IRG 1632)	46	104694 (A 16-32/5)	54
102450 (IPN 1655)	34	103220 (IEG 1631)	40	103939 (IRG 3232)	46	104753 (RA 1643)	54
102451 (IPN 3235)	34	103221 (IEG 1641)	40	103943 (IRG 1643)	46	104754 (RA 1653)	54
102452 (IPN 3245)	34	103222 (IEG 1651)	40	103944 (IRG 1653)	46	104756 (RA 3243)	54
102453 (IPN 3255)	34	103223 (IEG 3231)	40	103946 (IRG 3243)	46	104757 (RA 3253)	54
102520 (IPB 1631)	34	103224 (IEG 3241)	40	103947 (IRG 3253)	46	104812 (A16-32/5-0)	54
102522 (IPB 1651)	34	103225 (IEG 3251)	40	104020 (IRGN 6331)	48	104814 (A1653/43-0)	54
102524 (IPB 3241)	34	103226 (IEG 1632)	40	104021 (IRGN 6341)	48	104817 (A3253/43-0)	54
102526 (IPB 1632)	34	103227 (IEG 1642)	40	104022 (IRGN 6351)	48	104866 (SA-1)	56
102525 (IPB 3251)	34	103229 (IEG 3232)	40	104023 (IRGN 6332)	48	104867 (SA-1S)	56
102528 (IPB 1652)	34	103230 (IEG 3242)	40	104024 (IRGN 6342)	48	104934 (SA-2)	56
102530 (IPB 3242)	34	103233 (IEG 1643)	40	104025 (IRGN 6352)	48	104935 (SA-2S)	56
102531 (IPB 3252)	34	103234 (IEG 1653)	40	104027 (IRGN 6343)	48	104986 (SA-3)	56
102534 (IPB 1653)	34	103236 (IEG 3243)	40	104028 (IRGN 6353)	48	104989 (SA-4)	56
102537 (IPB 3253)	34	103237 (IEG 3253)	40	104029 (IRGN 6335)	48	105040 (BZS 1631)	58
102624 (IPNO 1653)	34	103238 (IEG 1635)	40	104030 (IRGN 6345)	48	105041 (BZS 1641)	58
102627 (IPNO 3253)	34	103239 (IEG 1645)	40	104031 (IRGN 6355)	48	105042 (BZS 1651)	58
102700 (IPG 1631)	36	103240 (IEG 1655)	40	104070 (IRRN 1631)	48	105043 (BZS 3231)	58
102701 (IPG 1641)	36	103241 (IEG 3235)	40	104071 (IRRN 1641)	48	105044 (BZS 3241)	58
102702 (IPG 1651)	36	103242 (IEG 3245)	40	104072 (IRRN 1651)	48	105045 (BZS 3251)	58
102703 (IPG 3231)	36	103243 (IEG 3255)	40	104073 (IRRN 3231)	48	105046 (BZS 1632)	58
102704 (IPG 3241)	36	103310 (IEGB 1631)	40	104074 (IRRN 3241)	48	105047 (BZS 1642)	58
102705 (IPG 3251)	36	103311 (IEGB 1641)	40	104075 (IRRN 3251)	48	105048 (BZS 1652)	58
102706 (IPG 1632)	36	103312 (IEGB 1651)	40	104076 (IRRN 1632)	48	105049 (BZS 3232)	58
102709 (IPG 3232)	36	103313 (IEGB 3231)	40	104079 (IRRN 3232)	48	105050 (BZS 3242)	58
102713 (IPG 1643)	36	103314 (IEGB 3241)	40	104083 (IRRN 1643)	48	105051 (BZS 3252)	58
102714 (IPG 1653)	36	103315 (IEGB 3251)	40	104084 (IRRN 1653)	48	105053 (BZS 1643)	58
102716 (IPG 3243)	36	103316 (IEGB 1632)	40	104086 (IRRN 3243)	48	105054 (BZS 1653)	58
102717 (IPG 3253)	36	103317 (IEGB 1642)	40	104087 (IRRN 3253)	48	105056 (BZS 3243)	58
102718 (IPG 1635)	36	103318 (IEGB 1652)	40	104088 (IRRN 1635)	48	105057 (BZS 3253)	58
102719 (IPG 1645)	36	103319 (IEGB 3232)	40	104089 (IRRN 1645)	48	105130 (BZG 1631)	58
102720 (IPG 1655)	36	103320 (IEGB 3242)	40	104090 (IRRN 1655)	48	105131 (BZG 1641)	58
102721 (IPG 3235)	36	103321 (IEGB 3252)	40	104091 (IRRN 3235)	48	105132 (BZG 1651)	58
102722 (IPG 3245)	36	103323 (IEGB 1643)	40	104092 (IRRN 3245)	48	105133 (BZG 3231)	58
102723 (IPG 3255)	36	103324 (IEGB 1653)	40	104093 (IRRN 3255)	48	105134 (BZG 3241)	58
102797 (IPG 6343)	36	103326 (IEGB 3243)	40	104160 (IRRB 1631)	48	105135 (BZG 3251)	58
102798 (IPGN 6353)	36	103327 (IEGB 3253)	40	104162 (IRRB 1651)	48	105136 (BZG 1632)	58
102800 (IPG 6345)	36	103400 (IEGN 6331)	42	104164 (IRRB 3241)	48	105137 (BZG 1642)	58
102820 (IPGN 6331)	36	103401 (IEGN 6341)	42	104165 (IRRB 3251)	48	105139 (BZG 3232)	58
102821 (IPGN 6341)	36	103402 (IEGN 6351)	42	104166 (IRRB 1632)	48	105140 (BZG 3242)	58
102822 (IPGN 6351)	36	103403 (IEGN 6332)	42	104168 (IRRB 1652)	48	105143 (BZG 1643)	58
102823 (IPGN 6332)	36	103407 (IEGN 6343)	42	104170 (IRRB 3242)	48	105144 (BZG 1653)	58
102870 (IPGN 12531)	38	103408 (IEGN 6353)	42	104171 (IRRB 3252)	48	105146 (BZG 3243)	58
102871 (IPGN 12541)	38	103410 (IEGN 6345)	42	104174 (IRRB 1653)	48	105147 (BZG 3253)	58
102872 (IPGN 12551)	38	103480 (IEGN 12531)	42	104177 (IRRB 3253)	48	105220 (BZS 1631v)	58
102873 (IPGN 12532)	38	103481 (IEGN 12541)	42	104264 (IRRNO 1653)	50	105221 (BZS 1641v)	58
102877 (IPGN 12543)	38	103482 (IEGN 12551)	42	104266 (IRRNO 3243)	50	105222 (BZS 1651v)	58
102878 (IPGN 12553)	38	103483 (IEGN 12531-p)	42	104267 (IRRNO 3253)	50	105223 (BZS 3231v)	58
102880 (IPGN 12545)	38	103484 (IEGN 12541-p)	42	104310 (IRRGN 1631)	50	105224 (BZS 3241v)	58
102881 (IPGN 12555)	38	103485 (IEGN 12551-p)	42	104311 (IRRGN 1641)	50	105225 (BZS 3251v)	58
102950 (IEN 1631)	38	103489 (IEGN 12532)	42	104312 (IRRGN 1651)	50	105226 (BZS 1632v)	58
102951 (IEN 1641)	38	103492 (IEGN 12532-p)	42	104313 (IRRGN 3231)	50	105227 (BZS 1642v)	58
102952 (IEN 1651)	38	103499 (IEGN 12543)	42	104314 (IRRGN 3241)	50	105228 (BZS 1652v)	58
102953 (IEN 3231)	38	103500 (IEGN 12553)	42	104315 (IRRGN 3251)	50	105229 (BZS 3232v)	58
102954 (IEN 3241)	38	103502 (IEGN 12543-p)	42	104324 (IRRG 1653)	50	105230 (BZS 3242v)	58
102955 (IEN 3251)	38	103503 (IEGN 12553-p)	42	104327 (IRRG 3253)	50	105231 (BZS 3252v)	58
102956 (IE 1632)	38	103508 (IEGN 12545)	42	104328 (IRRGN 1635)	50	105233 (BZS 1643v)	58
102957 (IEN 1642)	38	103509 (IEGN 12555)	42	104329 (IRRGN 1645)	50	105234 (BZS 1653v)	58
102958 (IEN 1652)	38	103511 (IEGN 12545-p)	42	104330 (IRRGN 1655)	50	105236 (BZS 3243v)	58
102959 (IE 3232)	38	103512 (IEGN 12555-p)	42	104331 (IRRGN 3235)	50	105237 (BZS 3253v)	58
102960 (IEN 3242)	38	103570 (IERN 1631)	42	104332 (IRRGN 3245)	50	105238 (BZS 1635v)	58
102961 (IEN 3252)	38	103573 (IERN 3231)	42	104333 (IRRGN 3255)	50	105239 (BZS 1645v)	58
102963 (IEN 1643)	38	103576 (IERN 1632)	42	104400 (IRRGB 1631)	50	105240 (BZS 1655v)	58
102964 (IEN 1653)	38	103579 (IERN 3232)	42	104402 (IRRGB 1651)	50	105241 (BZS 3235v)	58
102966 (IEN 3243)	38	103583 (IERN 1643)	42	104404 (IRRGB 3241)	50	105242 (BZS 3245v)	58
102967 (IEN 3253)	38	103584 (IERN 1653)	42	104405 (IRRGB 3251)	50	105243 (BZS 3255v)	58
102968 (IEN 1635)	38	103586 (IERN 3243)	42	104406 (IRRGB 1632)	50	105310 (BZG 1631v)	60
102969 (IEN 1645)	38	103587 (IERN 3253)	42	104408 (IRRGB 1652)	50	105311 (BZG 1641v)	60
102970 (IEN 1655)	38	103674 (IERB 1653)	44	104410 (IRRGB 3242)	50	105312 (BZG 1651v)	60
102971 (IEN 3235)	38	103676 (IERB 3253)	44	104411 (IRRGB 3252)	50	105313 (BZG 3231v)	60
102972 (IEN 3245)	38	103750 (VZ 16)	44	104414 (IRRGB 1653)	50	105314 (BZG 3241v)	60
102973 (IEN 3255)	38	103751 (VZ 16S)	44	104416 (IRRGB 3243)	50	105315 (BZG 3251v)	60
103043 (IEN 6332)	38	103752 (VZ 16/Black)	44	104417 (IRRGB 3253)	50	105316 (BZG 1632v)	60
103047 (IEN 6343)	38	103753 (VZ 16S/Black)	44	104490 (IRRGN 6331)	52	105317 (BZG 1642v)	60
103048 (IEN 6353)	38	103754 (VZ 16DK)	44	104491 (IRRGN 6341)	52	105318 (BZG 1652v)	60
103130 (IEB 1631)	40	103755 (VZ 16IT)	44	104492 (IRRGN 6351)	52	105319 (BZG 3232v)	60
103131 (IEB 1641)	40	103756 (VZ 16 GB)	44	104493 (IRRGN 6332)	52	105320 (BZG 3242v)	60
103132 (IEB 1651)	40	103757 (VZ 16T13)	44	104497 (IRRGN 6343)	52	105321 (BZG 3252v)	60
103133 (IEB 3231)	40	103758 (VZ 16T23)	44	104498 (IRRGN 6353)	52	105323 (BZG 1643v)	60
103134 (IEB 3241)	40	103759 (VZ 16T25)	44	104540 (IRRGN 12531)	52	105324 (BZG 1653v)	60

105326 (BZG 3243v)	60	200083 (ROS 1603/S)	75	200314 (ROSP 1632 D)	82	200864 (ROS 4/V-52)	89
105327 (BZG 3253v)	60	200084 (ROS 1605)	75	200315 (ROSP 1632 D/S)	82	200865 (ROS 4/V-52/S)	89
105328 (BZG 1635v)	60	200085 (ROS 1605/S)	75	200316 (ROSP 3232 D)	82	200866 (ROS 4/V-50)	89
105329 (BZG 1645v)	60	200086 (ROS 1607)	75	200317 (ROSP 3232 D/S)	82	200867 (ROS 4/V-50/S)	89
105330 (BZG 1655v)	60	200087 (ROS 1607/S)	75	200318 (ROSP 1631 D)	82	201000 (ROS 5-6/FI-01)	90
105331 (BZG 3235v)	60	200088 (ROS 3201)	75	200319 (ROSP 1631 D/S)	82	201001 (ROS 5-6/FI-01/S)	90
105332 (BZG 3245v)	60	200090 (ROS 1600)	75	200320 (ROSP 3231 D)	82	201002 (ROS 5-6/I-10)	90
105333 (BZG 3255v)	60	200092 (ROS 1602)	75	200321 (ROSP 3231 D/S)	82	201003 (ROS 5-6/I-10/S)	90
105400 (BZG 6331v)	60	200093 (ROS 1602/S)	75	200322 (ROSP 1630 D)	82	201004 (ROS 5-6/I-11)	90
105401 (BZG 6341v)	60	200094 (ROS 1604)	75	200323 (ROSP 1630 D/S)	82	201005 (ROS 5-6/I-11/S)	90
105402 (BZG 6351v)	60	200095 (ROS 1604/S)	75	200324 (ROSP 3230 D)	82	201006 (ROS 5-6/I-12)	90
105403 (BZG 6332v)	60	200096 (ROS 3200)	75	200325 (ROSP 3230 D/S)	82	201007 (ROS 5-6/I-12/S)	90
105404 (BZG 6342v)	60	200120 (ROS-FI 1600 D/C)	76	200340 (ROSPG 1631 D)	83	201008 (ROS 5-6/I-13)	90
105405 (BZG 6352v)	60	200121 (ROS-FI 1600 D/C/S)	76	200341 (ROSPG 1631 D/S)	83	201009 (ROS 5-6/I-13/S)	90
105406 (BZG 6333v)	60	200122 (ROS-FI 1603 D)	76	200342 (ROSPG 3231 D)	83	201010 (ROS 5-6/I-14)	90
105407 (BZG 6343v)	60	200123 (ROS-FI 1603 D/S)	76	200343 (ROSPG 3231 D/S)	83	201011 (ROS 5-6/I-14/S)	90
105408 (BZG 6353v)	60	200124 (ROS-FI 3203 D)	76	200344 (ROSPG 1630 D)	83	201012 (ROS 5-6/I-15)	90
105409 (BZG 6335v)	60	200125 (ROS-FI 3203 D/S)	76	200345 (ROSPG 1630 D/S)	83	201013 (ROS 5-6/I-15/S)	90
105410 (BZG 6345v)	60	200126 (ROS-FI 1602 D/C)	76	200346 (ROSPG 3230 D)	83	201014 (ROS 5-6/I-16)	90
105411 (BZG 6355v)	60	200127 (ROS-FI 1602 D/C/S)	76	200347 (ROSPG 3230 D/S)	83	201015 (ROS 5-6/I-16/S)	90
105450 (BZG 12531v)	60	200128 (ROS-FI 3202 D/C)	76	200360 (VZS 165)	84	201016 (ROS 5-6/I-50)	91
105451 (BZG 12541v)	60	200129 (ROS-FI 3202 D/C/S)	76	200361 (VZS 165/S)	84	201017 (ROS 5-6/I-50/S)	91
105452 (BZG 12551v)	60	200140 (ROS-FI 1600 D/A)	76	200362 (VZS 325)	84	201018 (ROS 5-6/I-51)	91
105453 (BZG 12532v)	60	200141 (ROS-FI 1600 D/A/S)	76	200363 (VZS 325/S)	84	201019 (ROS 5-6/I-51/S)	91
105454 (BZG 12542v)	60	200160 (ROS-I 1601 D)	77	200364 (VZS 164)	84	201020 (ROS 5-6/I-52)	91
105455 (BZG 12552v)	60	200161 (ROS-I 1601 D/S)	77	200365 (VZS 164/S)	84	201021 (ROS 5-6/I-52/S)	91
105457 (BZG 12543v)	60	200162 (ROS-I 1603 D)	77	200366 (VZS 324)	84	201022 (ROS 5-6/I-53)	91
105458 (BZG 12553v)	60	200163 (ROS-I 1603 D/S)	77	200367 (VZS 324/S)	84	201023 (ROS 5-6/I-53/S)	91
105459 (BZG 12535v)	60	200164 (ROS-I 3201 D)	77	200380 (VPS 1653)	84	201024 (ROS 5-6/I-54)	91
105460 (BZG 12545v)	60	200165 (ROS-I 3201 D/S)	77	200382 (VPS 3253)	84	201025 (ROS 5-6/I-54/S)	91
105461 (BZG 12555v)	60	200166 (ROS-I 1600 D)	77	200400 (ROP 1653-VZ)	85	201026 (ROS 5-6/I-55)	91
105700 (ND 105-0757)	62	200167 (ROS-I 1600 D/S)	77	200401 (ROP 1653-VZ/S)	85	201027 (ROS 5-6/I-55/S)	91
105701 (ND 16CPG1)	62	200168 (ROS-I 1602 D)	77	200402 (ROP 1653-2xVZ)	85	201028 (ROS 5-6/I-56)	91
105702 (ND 16CPG2)	62	200169 (ROS-I 1602 D/S)	77	200403 (ROP 1653-2xVZ/S)	85	201029 (ROS 5-6/I-56/S)	91
105703 (ND 32CPG1)	62	200170 (ROS-I 3200 D)	77	200404 (ROP 1653-3xVZ)	85	201040 (ROS 5-6/x-01)	92
105704 (ND 32CPG2)	62	200171 (ROS-I 3200 D/S)	77	200405 (ROP 1653-3xVZ/S)	85	201042 (ROS 5-6/x-10)	92
105705 (ND 63CPG1)	62	200190 (ROS-I 1601 D/A)	78	200406 (ROP 1653)	85	201043 (ROS 5-6/x-10/S)	92
105706 (ND 125CPG1)	62	200191 (ROS-I 1601 D/A/S)	78	200408 (ROP 3253)	85	201044 (ROS 5-6/x-12)	92
105720 (KV 1632)	62	200192 (ROS-I 1603 D/A)	78	200410 (ROP 1643)	85	201045 (ROS 5-6/x-12/S)	92
105721 (KV 1643)	62	200193 (ROS-I 1603 D/A/S)	78	200412 (ROP 3243)	85	201046 (ROS 5-6/x-14)	92
105722 (KV 1653)	62	200194 (ROS-I 3201 D/A)	78	200416 (ROP 1653-VZ/IVN)	86	201047 (ROS 5-6/x-14/S)	92
105723 (KV 3243)	62	200195 (ROS-I 3201 D/A/S)	78	200417 (ROP 1653-VZ/S/IVN)	86	201048 (ROS 5-6/x-15)	92
105724 (KV 3253)	62	200196 (ROS-I 1600 D/A)	78	200418 (ROP 1653-2xVZ/IVN)	86	201049 (ROS 5-6/x-15/S)	92
105730 (ND 16CZG1)	62	200197 (ROS-I 1600 D/A/S)	78	200419 (ROP 1653-2xVZ/S/IVN)	86	201050 (ROS 5-6/x-16)	92
105731 (ND 32CZG1)	62	200198 (ROS-I 1602 D/A)	78	200420 (ROP 1653-3xVZ/IVN)	86	201051 (ROS 5-6/x-16/S)	92
105732 (ND 63CZG1)	62	200199 (ROS-I 1602 D/A/S)	78	200421 (ROP 1653-3xVZ/S/IVN)	86	201052 (ROS 5-6/x-17)	92
105760 (ND 105-2177)	62	200200 (ROS-I 3200 D/A)	78	200422 (ROP 1653/IVN)	86	201053 (ROS 5-6/x-17/S)	92
105761 (ND 105-2677)	63	200201 (ROS-I 3200 D/A/S)	78	200424 (ROP 3253/IVN)	86	201054 (ROS 5-6/x-18)	92
105761 (ND 105-2677)	118	200220 (ROS 1601 D)	79	200426 (ROP 1643/IVN)	86	201055 (ROS 5-6/x-18/S)	92
105770 (ND 143-0245)	63	200222 (ROS 1603 D)	79	200428 (ROP 3243/IVN)	86	201056 (ROS 5-6/x-41)	93
105780 (SPg 16)	63	200223 (ROS 1603 D/S)	79	200430 (ROK/FI-51)	87	201058 (ROS 5-6/x-50)	93
105790 (PR 10)	63	200224 (ROS 1605 D)	79	200431 (ROK/FI-51/S)	87	201059 (ROS 5-6/x-50/S)	93
200000 (ROS-FI 1600/C)	72	200225 (ROS 1605 D/S)	79	200432 (ROK/FI-55)	87	201060 (ROS 5-6/x-52)	93
200001 (ROS-FI 1600/C/S)	72	200226 (ROS 1607 D)	79	200433 (ROK/FI-55/S)	87	201061 (ROS 5-6/x-52/S)	93
200002 (ROS-FI 1603)	72	200227 (ROS 1607 D/S)	79	200434 (ROK/I-38)	87	201062 (ROS 5-6/x-54)	93
200003 (ROS-FI 1603/S)	72	200228 (ROS 3201 D)	79	200435 (ROK/I-38/S)	87	201063 (ROS 5-6/x-54/S)	93
200004 (ROS-FI 3203)	72	200230 (ROS 1600 D)	79	200436 (ROK/x-05)	87	201064 (ROS 5-6/x-55)	93
200005 (ROS-FI 3203/S)	72	200232 (ROS 1602 D)	79	200437 (ROK/x-05/S)	87	201065 (ROS 5-6/x-55/S)	93
200006 (ROS-FI 1602/C)	72	200233 (ROS 1602 D/S)	79	200438 (ROK/x-70)	87	201080 (ROS M6/I-02)	94
200007 (ROS-FI 1602/C/S)	72	200234 (ROS 1604 D)	79	200439 (ROK/x-70/S)	87	201081 (ROS M6/I-02/S)	94
200008 (ROS-FI 3202/C)	72	200235 (ROS 1604 D/S)	79	200440 (ROK/x-55 V)	87	201082 (ROS M6/I-03)	94
200009 (ROS-FI 3202/C/S)	72	200236 (ROS 3200 D)	79	200441 (ROK/x-55 V/S)	87	201083 (ROS M6/I-03/S)	94
200020 (ROS-FI 1600 A)	72	200260 (ROSP 4VZ)	80	200800 (ROS 4/I-12)	88	201090 (ROS M6/I-01)	94
200021 (ROS-FI 1600 A/S)	72	200261 (ROSP 4VZ/S)	80	200801 (ROS 4/I-12/S)	88	201100 (ROS M6/x-02)	95
200030 (ROS-I 1601)	73	200262 (ROSP 6VZ)	80	200802 (ROS 4/I-10)	88	201101 (ROS M6/x-02/S)	95
200031 (ROS-I 1601/S)	73	200263 (ROSP 6VZ/S)	80	200803 (ROS 4/I-10/S)	88	201102 (ROS M6/x-03)	95
200032 (ROS-I 1603)	73	200264 (ROSP 1632)	80	200804 (ROS 4/I-52)	88	201103 (ROS M6/x-03/S)	95
200033 (ROS-I 1603/S)	73	200265 (ROSP 1632/S)	80	200805 (ROS 4/I-52/S)	88	201110 (ROS M6/x-01)	95
200034 (ROS-I 3201)	73	200266 (ROSP 3232)	80	200806 (ROS 4/I-50)	88	201500 (ROS 7/I-02)	96
200035 (ROS-I 3201/S)	73	200267 (ROSP 3232/S)	80	200807 (ROS 4/I-50/S)	88	201501 (ROS 7/I-02/S)	96
200036 (ROS-I 1600)	73	200268 (ROSP 1631)	80	200820 (ROS 4/x-12)	88	201502 (ROS 7/I-04)	96
200037 (ROS-I 1600/S)	73	200269 (ROSP 1631/S)	80	200821 (ROS 4/x-12/S)	88	201503 (ROS 7/I-04/S)	96
200038 (ROS-I 1602)	73	200270 (ROSP 3231)	80	200822 (ROS 4/x-10)	88	201504 (ROS 7/I-42)	96
200039 (ROS-I 1602/S)	73	200271 (ROSP 3231/S)	80	200823 (ROS 4/x-10/S)	88	201505 (ROS 7/I-42/S)	96
200040 (ROS-I 3200)	73	200272 (ROSP 1630)	80	200824 (ROS 4/x-52)	88	201506 (ROS 7/I-44)	96
200041 (ROS-I 3200/S)	73	200273 (ROSP 1630/S)	80	200825 (ROS 4/x-52/S)	88	201507 (ROS 7/I-44/S)	96
200060 (ROS-I 1601 A)	74	200274 (ROSP 3230)	80	200826 (ROS 4/x-50)	88	201520 (ROS 7/x-02)	96
200061 (ROS-I 1601 A/S)	74	200275 (ROSP 3230/S)	80	200827 (ROS 4/x-50/S)	88	201521 (ROS 7/x-02/S)	96
200062 (ROS-I 1603 A)	74	200290 (ROSPG 1631)	81	200840 (ROS 4/V-12 LP)	89	201522 (ROS 7/x-42)	96
200063 (ROS-I 1603 A/S)	74	200291 (ROSPG 1631/S)	81	200841 (ROS 4/V-12 LP/S)	89	201533 (ROS 7/x-42/S)	96
200064 (ROS-I 3201 A)	74	200292 (ROSPG 3231)	81	200842 (ROS 4/V-10 LP)	89	201540 (ROS 7/I-01)	97
200065 (ROS-I 3201 A/S)	74	200293 (ROSPG 3231/S)	81	200843 (ROS 4/V-10 LP/S)	89	201541 (ROS 7/I-01/S)	97
200066 (ROS-I 1600 A)	74	200294 (ROSPG 1630)	81	200844 (ROS 4/V-52 LP)	89	201542 (ROS 7/I-03)	97
200067 (ROS-I 1600 A/S)	74	200295 (ROSPG 1630/S)	81	200845 (ROS 4/V-52 LP/S)	89	201543 (ROS 7/I-03/S)	97
200068 (ROS-I 1602 A)	74	200296 (ROSPG 3230)	81	200846 (ROS 4/V-50 LP)	89	201544 (ROS 7/I-11)	97
200069 (ROS-I 1602 A/S)	74	200297 (ROSPG 3230/S)	81	200847 (ROS 4/V-50 LP/S)	89	201545 (ROS 7/I-11/S)	97
200070 (ROS-I 3200 A)	74	200310 (ROSP 4VZ D)	82	200860 (ROS 4/V-12)	89	201546 (ROS 7/I-41)	97
200071 (ROS-I 3200 A/S)	74	200311 (ROSP 4VZ D/S)	82	200861 (ROS 4/V-12/S)	89	201547 (ROS 7/I-41/S)	97
200080 (ROS 1601)	75	200312 (ROSP 6VZ D)	82	200862 (ROS 4/V-10)	89	201548 (ROS 7/I-43)	97
200082 (ROS 1603)	75	200313 (ROSP 6VZ D/S)	82	200863 (ROS 4/V-10/S)	89	201549 (ROS 7/I-43/S)	97

201550 (ROS 7/I-51)	97	202105 (ROS 11/I-57/S)	103	203027 (ROS 16/I-112/S)	107	203189 (ROSG 16/I-506/S)	109
201551 (ROS 7/I-51/S)	97	202106 (ROS 11/I-65)	103	203028 (ROS 16/x-112)	107	203190 (ROSG 16/x-506)	109
201570 (ROS 7/x-01)	98	202107 (ROS 11/I-65/S)	103	203029 (ROS 16/x-112/S)	107	203191 (ROSG 16/x-506/S)	109
201571 (ROS 7/x-01/S)	98	202108 (ROS 11/I-66)	103	203030 (ROS 16/FI-117)	107	203200 (ROS 16/FI-603)	109
201572 (ROS 7/x-41)	98	202109 (ROS 11/I-66/S)	103	203031 (ROS 16/FI-117/S)	107	203201 (ROS 16/FI-603/S)	109
201573 (ROS 7/x-41/S)	98	202110 (ROS 11/I-64)	103	203032 (ROS 16/I-117)	107	203202 (ROS 16/I-603)	109
202000 (ROS 11/FI-01)	99	202111 (ROS 11/I-64/S)	103	203033 (ROS 16/I-117/S)	107	203203 (ROS 16/I-603/S)	109
202002 (ROS 11/FI-03)	99	202112 (ROS 11/I-67)	103	203034 (ROS 16/x-117)	107	203204 (ROS 16/x-603)	109
202004 (ROS 11/FI-05)	99	202113 (ROS 11/I-67/S)	103	203035 (ROS 16/x-117/S)	107	203205 (ROS 16/x-603/S)	109
202006 (ROS 11/FI-11)	99	202114 (ROS 11/I-69)	103	203036 (ROS 16/FI-123)	107	204000 (ROS 11S/FI-12)	110
202007 (ROS 11/FI-11/S)	99	202115 (ROS 11/I-69/S)	103	203037 (ROS 16/FI-123/S)	107	204001 (ROS 11S/FI-12/S)	110
202008 (ROS 11/FI-12)	99	202116 (ROS 11/I-68)	103	203038 (ROS 16/I-123)	107	204002 (ROS 11S/FI-14)	110
202009 (ROS 11/FI-12/S)	99	202117 (ROS 11/I-68/S)	103	203039 (ROS 16/I-123/S)	107	204003 (ROS 11S/FI-14/S)	110
202010 (ROS 11/FI-14)	99	202118 (ROS 11/I-61)	103	203040 (ROS 16/x-123)	107	204004 (ROS 11S/FI-21)	110
202011 (ROS 11/FI-14/S)	99	202119 (ROS 11/I-61/S)	103	203041 (ROS 16/x-123/S)	107	204005 (ROS 11S/FI-21/S)	110
202012 (ROS 11/FI-15)	99	202120 (ROS 11/I-62)	103	203042 (ROS 16/FI-128)	108	204020 (ROS 11S/FI-12/P)	111
202013 (ROS 11/FI-15/S)	99	202121 (ROS 11/I-62/S)	103	203043 (ROS 16/FI-128/S)	108	204021 (ROS 11S/FI-12/P/S)	111
202014 (ROS 11/FI-65)	99	202122 (ROS 11/I-63)	103	203044 (ROS 16/I-128)	108	204022 (ROS 11S/FI-14/P)	111
202015 (ROS 11/FI-65/S)	99	202123 (ROS 11/I-63/S)	103	203045 (ROS 16/I-128/S)	108	204023 (ROS 11S/FI-14/P/S)	111
202016 (ROS 11/FI-632)	99	202150 (ROS 11/x-01)	104	203046 (ROS 16/x-128)	108	204024 (ROS 11S/FI-21/P)	111
202017 (ROS 11/FI-632/S)	99	202152 (ROS 11/x-03)	104	203047 (ROS 16/x-128/S)	108	204025 (ROS 11S/FI-21/P/S)	111
202018 (ROS 11/FI-66)	99	202154 (ROS 11/x-05)	104	203048 (ROS 16/FI-134)	108	204040 (ROS 12SD/FI-21/P)	112
202019 (ROS 11/FI-66/S)	99	202156 (ROS 11/x-11)	104	203049 (ROS 16/FI-134/S)	108	204041 (ROS 12SD/FI-21/P/S)	112
202020 (ROS 11/FI-64)	100	202157 (ROS 11/x-11/S)	104	203050 (ROS 16/I-134)	108	204042 (ROS 12SD/FI-27/P)	112
202021 (ROS 11/FI-64/S)	100	202158 (ROS 11/x-14)	104	203051 (ROS 16/I-134/S)	108	204043 (ROS 12SD/FI-27/P/S)	112
202022 (ROS 11/FI-26)	100	202159 (ROS 11/x-14/S)	104	203052 (ROS 16/x-134)	108	204044 (ROS 12SD/23/P)	112
202023 (ROS 11/FI-26/S)	100	202160 (ROS 11/x-65)	104	203053 (ROS 16/x-134/S)	108	204045 (ROS 12SD/23/P/S)	112
202024 (ROS 11/FI-31)	100	202161 (ROS 11/x-65/S)	104	203070 (ROS 16/FI-203)	108	204046 (ROS 12SD/24/PR)	112
202025 (ROS 11/FI-31/S)	100	202162 (ROS 11/x-632)	104	203071 (ROS 16/FI-203/S)	108	204047 (ROS 12SD/24/PR/S)	112
202026 (ROS 11/FI-67)	100	202163 (ROS 11/x-632/S)	104	203072 (ROS 16/I-203)	108	204060 (ROS 16S/FI-425)	113
202027 (ROS 11/FI-67/S)	100	202164 (ROS 11/x-66)	104	203073 (ROS 16/I-203/S)	108	204061 (ROS 16S/FI-425/S)	113
202028 (ROS 11/FI-69)	100	202165 (ROS 11/x-66/S)	104	203074 (ROS 16/x-203)	108	204062 (ROSG 16S/FI-412)	113
202029 (ROS 11/FI-69/S)	100	202166 (ROS 11/x-64)	104	203075 (ROS 16/x-203/S)	108	204063 (ROSG 16S/FI-412/S)	113
202030 (ROS 11/FI-68)	100	202167 (ROS 11/x-64/S)	104	203076 (ROS 16/FI-206)	108	204070 (ROS 16S/FI-506)	113
202031 (ROS 11/FI-68/S)	100	202168 (ROS 11/x-32/24 V)	105	203077 (ROS 16/FI-206/S)	108	204071 (ROS 16S/FI-506/S)	113
202032 (ROS 11/FI-70)	100	202169 (ROS 11/x-32/24 V/S)	105	203078 (ROS 16/I-206)	108	204072 (ROSG 16S/FI-506)	113
202033 (ROS 11/FI-70/S)	100	202170 (ROS 11/x-67)	105	203079 (ROS 16/I-206/S)	108	204073 (ROSG 16S/FI-506/S)	113
202034 (ROS 11/FI-21)	100	202171 (ROS 11/x-67/S)	105	203080 (ROS 16/x-206)	108	204080 (ROS 16S/FI-601)	113
202035 (ROS 11/FI-21/S)	100	202172 (ROS 11/x-68)	105	203081 (ROS 16/x-206/S)	108	204081 (ROS 16S/FI-601/S)	113
202036 (ROS 11/FI-22)	100	202173 (ROS 11/x-68/S)	105	203082 (ROS 16/FI-209)	108	204082 (ROSG 16S/FI-601)	113
202037 (ROS 11/FI-22/S)	100	202174 (ROS 11/x-70)	105	203083 (ROS 16/FI-209/S)	108	204083 (ROSG 16S/FI-601/S)	113
202038 (ROS 11/FI-23)	100	202175 (ROS 11/x-70/S)	105	203084 (ROS 16/I-209)	108	204100 (ROS 12S/FI-01)	114
202039 (ROS 11/FI-23/S)	100	202176 (ROS 11/x-69)	105	203085 (ROS 16/I-209/S)	108	204101 (ROS 12S/FI-01/S)	114
202040 (ROS 11/FI-24)	100	202177 (ROS 11/x-69/S)	105	203086 (ROS 16/x-209)	108	204102 (ROS 12S/FI-02)	114
202041 (ROS 11/FI-24/S)	100	202178 (ROS 11/x-21)	105	203087 (ROS 16/x-209/S)	108	204103 (ROS 12S/FI-02/S)	114
202042 (ROS 11/FI-25)	100	202179 (ROS 11/x-21/S)	105	203088 (ROS 16/FI-215)	108	204104 (ROS 12S/FI-03)	114
202043 (ROS 11/FI-25/S)	100	202180 (ROS 11/x-22)	105	203089 (ROS 16/FI-215/S)	108	204105 (ROS 12S/FI-03/S)	114
202060 (ROS 11/I-01)	101	202181 (ROS 11/x-22/S)	105	203090 (ROS 16/I-215)	108	204120 (ROS 12SG/FI-04)	114
202062 (ROS 11/I-11)	101	202182 (ROS 11/x-23)	105	203091 (ROS 16/I-215/S)	108	204121 (ROS 12SG/FI-04/S)	114
202063 (ROS 11/I-11/S)	101	202183 (ROS 11/x-23/S)	105	203092 (ROS 16/x-215)	108	204140 (ROS 24S/FI-01)	115
202064 (ROS 11/I-12)	101	202184 (ROS 11/x-25)	105	203093 (ROS 16/x-215/S)	108	204141 (ROS 24S/FI-01/S)	115
202065 (ROS 11/I-12/S)	101	202185 (ROS 11/x-25/S)	105	203094 (ROS 16/FI-221)	108	204142 (ROS 24S/FI-02)	115
202066 (ROS 11/I-13)	101	202186 (ROS 11/x-41)	105	203095 (ROS 16/FI-221/S)	108	204143 (ROS 24S/FI-02/S)	115
202067 (ROS 11/I-13/S)	101	202188 (ROS 11/x-43)	105	203096 (ROS 16/I-221)	108	204160 (ROS 24SG/FI-03)	115
202068 (ROS 11/I-14)	101	202190 (ROS 11/x-45)	105	203097 (ROS 16/I-221/S)	108	204161 (ROS 24SG/FI-03/S)	115
202069 (ROS 11/I-14/S)	101	202192 (ROS 11/x-51)	106	203098 (ROS 16/x-221)	108	205000 (ROS 8/Z)	116
202070 (ROS 11/I-15)	101	202193 (ROS 11/x-51/S)	106	203099 (ROS 16/x-221/S)	108	205001 (ROS 4/Z)	116
202071 (ROS 11/I-15/S)	101	202194 (ROS 11/x-54)	106	203100 (ROS 16/FI-225)	108	205002 (ROS 8/Z)	116
202072 (ROS 11/I-16)	101	202195 (ROS 11/x-54/S)	106	203101 (ROS 16/FI-225/S)	108	205003 (ROS 8/Z) - držiak	116
202073 (ROS 11/I-16/S)	101	202196 (ROS 11/x-61)	106	203102 (ROS 16/I-225)	108	205004 (ROS 4/Z) - držiak	116
202074 (ROS 11/I-17)	101	202197 (ROS 11/x-61/S)	106	203103 (ROS 16/I-225/S)	108	205005 (ROS 8/Z) - držiak	116
202075 (ROS 11/I-17/S)	101	202198 (ROS 11/x-62)	106	203104 (ROS 16/x-225)	108	205006 (ROS 5-6/Z)	116
202076 (ROS 11/I-21)	101	202199 (ROS 11/x-62/S)	106	203105 (ROS 16/x-225/S)	108	205007 (ROS 7/Z)	116
202077 (ROS 11/I-21/S)	101	203000 (ROS 16/FI-103)	107	203130 (ROS 16/FI-304)	109	205008 (ROS 11/Z)	116
202078 (ROS 11/I-22)	101	203001 (ROS 16/FI-103/S)	107	203131 (ROS 16/FI-304/S)	109	205009 (ROS 16/Z)	117
202079 (ROS 11/I-22/S)	101	203002 (ROS 16/I-103)	107	203132 (ROS 16/I-304)	109	205010 (ROSG 16/Z)	117
202080 (ROS 11/I-23)	102	203003 (ROS 16/FI-103/S)	107	203133 (ROS 16/I-304/S)	109	205011 (ROS 16/ZB)	117
202081 (ROS 11/I-23/S)	102	203004 (ROS 16/x-103)	107	203134 (ROS 16/x-304)	109	205012 (ROSG 16/ZB)	117
202082 (ROS 11/I-25)	102	203005 (ROS 16/x-103/S)	107	203135 (ROS 16/x-304/S)	109	205013 (ROS 16/ZC)	117
202083 (ROS 11/I-25/S)	102	203006 (ROS 16/FI-104)	107	203150 (ROS 16/FI-412)	109	205014 (ROSG 16/ZC)	117
202084 (ROS 11/I-26)	102	203007 (ROS 16/FI-104/S)	107	203151 (ROS 16/FI-412/S)	109	205110 (ROS 11S)	118
202085 (ROS 11/I-26/S)	102	203008 (ROS 16/I-104)	107	203152 (ROS 16/I-412)	109	205111 (ROS 16S)	118
202086 (ROS 11/I-632)	102	203009 (ROS 16/I-104/S)	107	203153 (ROS 16/I-412/S)	109	205112 (ROS 12S)	118
202087 (ROS 11/I-632/S)	102	203010 (ROS 16/x-104)	107	203154 (ROS 16/x-412)	109	205113 (ROS 24S)	118
202088 (ROS 11/I-32/24 V)	102	203011 (ROS 16/x-104/S)	107	203155 (ROS 16/x-412/S)	109	300000 (RS 2,5/0)	126
202089 (ROS 11/I-32/24 V/S)	102	203012 (ROS 16/FI-108)	107	203156 (ROSG 16/FI-411)	109	300001 (RS 2,5/1)	126
202090 (ROS 11/I-41)	102	203013 (ROS 16/FI-108/S)	107	203157 (ROSG 16/FI-411/S)	109	300002 (RS 2,5/2)	126
202092 (ROS 11/I-51)	102	203014 (ROS 16/I-108)	107	203158 (ROSG 16/I-411)	109	300003 (RS 2,5/3)	126
202093 (ROS 11/I-51/S)	102	203015 (ROS 16/I-108/S)	107	203159 (ROSG 16/I-411/S)	109	300004 (RS 2,5/4)	126
202094 (ROS 11/I-52)	102	203016 (ROS 16/x-108)	107	203160 (ROSG 16/x-411)	109	300005 (RS 2,5/6)	126
202095 (ROS 11/I-52/S)	102	203017 (ROS 16/x-108/S)	107	203161 (ROSG 16/x-411/S)	109	300006 (RS 2,5/7)	126
202096 (ROS 11/I-53)	102	203018 (ROS 16/FI-111)	107	203180 (ROS 16/FI-516)	109	300007 (RS 6/0)	126
202097 (ROS 11/I-53/S)	102	203019 (ROS 16/FI-111/S)	107	203181 (ROS 16/FI-516/S)	109	300008 (RS 6/1)	126
202098 (ROS 11/I-54)	102	203020 (ROS 16/I-111)	107	203182 (ROS 16/I-516)	109	300009 (RS 6/2)	126
202099 (ROS 11/I-54/S)	102	203021 (ROS 16/I-111/S)	107	203183 (ROS 16/I-516/S)	109	300010 (RS 6/3)	126
202100 (ROS 11/I-55)	102	203022 (ROS 16/x-111)	107	203184 (ROS 16/x-516)	109	300011 (RS 6/4)	126
202101 (ROS 11/I-55/S)	102	203023 (ROS 16/x-111/S)	107	203185 (ROS 16/x-516/S)	109	300012 (RS 6/6)	126
202102 (ROS 11/I-56)	103	203024 (ROS 16/FI-112)	107	203186 (ROSG 16/FI-506)	109	300013 (RS 6/7)	126
202103 (ROS 11/I-56/S)	103	203025 (ROS 16/FI-112/S)	107	203187 (ROSG 16/FI-506/S)	109	300014 (RS 10/0)	126
202104 (ROS 11/I-57)	103	203026 (ROS 16/I-112)	107	203188 (ROSG 16/I-506)	109	300015 (RS 10/1)	126

300016 (RS 10/2)	126	300400 (6336-10)	130	400352 (S-Box 306)	146	400862 (UM 11/02)	152
300017 (RS 10/3)	126	300401 (6336-17)	130	400353 (S-Box 406)	146	400863 (UM 13/02)	152
300018 (RS 10/4)	126	300402 (6336-20)	130	400354 (S-Box 506)	146	400864 (UM 16/02), (UM 16-16/02)	152
300019 (RS 10/6)	126	300403 (6336-27)	130	400355 (S-Box 606)	146	400865 (UM 21/02), (UM 21-20/02)	152
300020 (RS 10/7)	126	300404 (6336-30)	130	400356 (S-Box 706)	146	400866 (UM 29/02)	152
300021 (RS 25/0)	126	300405 (6336-37)	130	400357 (S-Box 806)	146	400867 (UM 36/02)	152
300022 (RS 25/1)	126	300406 (6336-50)	130	400360 (S-Box 116)	146	400880 (TP 7)	152
300023 (RS 25/2)	126	300407 (6336-57)	130	400361 (S-Box 216)	146	400881 (TP 9)	152
300024 (RS 25/3)	126	300408 (6336-60)	130	400362 (S-Box 316)	146	400882 (TP 11)	152
300025 (RS 25/4)	126	300409 (6336-67)	130	400363 (S-Box 416)	146	400883 (TP 13)	152
300026 (RS 25/6)	126	300410 (6336-70)	130	400364 (S-Box 516)	146	400884 (TP 16), (TP16-16)	152
300027 (RS 25/7)	126	300411 (6336-77)	130	400365 (S-Box 616)	146	400885 (TP 21), (TP20-21)	152
300028 (RS 50/0)	126	300430 (6110-06)	130	400366 (S-Box 716)	146	400886 (TP 29)	152
300029 (RS 50/1)	126	300431 (6111-06)	130	400367 (S-Box 816)	146	400887 (TP 36)	152
300030 (RS 50/2)	126	300432 (6112-06)	130	400400 (PO 105 5P/4)	147	400900 (TV-M 12)	153
300031 (RS 50/3)	126	300440 (6311-06)	130	400401 (PO 105 5P/10)	147	400901 (TV-M 16)	153
300032 (RS 50/4)	126	300441 (6311-07)	130	400402 (PO 105 3P/4)	147	400902 (TV-M 20)	153
300033 (RS 50/6)	126	300442 (6311-04)	130	400403 (PO 105 4P/4)	147	400903 (TV-M 25)	153
300034 (RS 50/7)	126	300443 (6311-05)	130	400404 (PO 105 3P/4F)	147	400904 (TV-M 32)	153
300035 (RS 120/0)	126	300460 (6313-14 MP)	131	400405 (PO 105 3P/10F)	147	400905 (TV-M 40)	153
300036 (RS 120/1)	126	300461 (6314-14 MP)	131	400406 (PO 105 3P/10)	147	400906 (TV-M 50)	153
300037 (RS 120/2)	126	300470 (6353-30)	131	400410 (PO 125 6P/4)	147	400907 (TV-M 63)	153
300038 (RS 120/3)	126	300471 (6354-30)	131	400411 (PO 125 6P/10)	147	400920 (TVM-M 12)	153
300039 (RS 120/4)	126	300480 (SV 35)	131	400420 (PO 155 9P/4)	147	400921 (TVM-M 16)	153
300040 (RS 120/6)	126	300481 (SVK 35)	131	400421 (PO 155 9P/10)	147	400922 (TVM-M 20)	153
300041 (RS 120/7)	126	300490 (SV 95)	131	400422 (PO 155 3P/10)	147	400923 (TVM-M 25)	153
300080 (RSDPS-00/7)	128	300491 (SVK 95)	131	400423 (PO 155 6P/10)	147	400924 (TVM-M 32)	153
300081 (RSDPS-10/7)	128	300510 (HSV 35)	132	400500 (6480-10)	148	400925 (TVM-M 40)	153
300082 (RSDPS-20/7)	128	300511 (HSV 35 K)	132	400501 (6481-10)	148	400926 (TVM-M 50)	153
300083 (RSDPS-30/7)	128	300520 (HSV 95)	132	400502 (6481-14)	148	400927 (TVM-M 63)	153
300100 (PRS/2)	127	300521 (HSV 95 K)	132	400510 (6482-10)	148	400940 (UM-M 12/02)	153
300101 (PRS/25/2)	127	300530 (6323-95 P)	132	400511 (6482-11)	148	400941 (UM-M 16/02)	153
300102 (RSDPS-01)	128	300531 (6323-95 PK)	132	400512 (6482-14)	148	400942 (UM-M 20/02)	153
300103 (RSDPS-11)	128	300540 (ND SV 35)	132	400520 (6483-11)	148	400943 (UM-M 25/02)	153
300104 (RSDPS-21)	128	300541 (ND SV 95)	132	400600 (6457-10)	149	400944 (UM-M 32/02)	153
300105 (RSDPS-31)	128	300550 (ND HSV 35)	133	400601 (6457-11)	149	400945 (UM-M 40/02)	153
300110 (P 6/2)	127	300551 (ND HSV 95)	133	400602 (6457-13)	149	400946 (UM-M 50/02)	153
300111 (P 10/2)	127	300600 (EVP-S)	133	400603 (6457-15)	149	400947 (UM-M 63/02)	153
300112 (P 25/2)	127	300601 (EVP-SK s krytom)	133	400604 (6457-19)	149	400960 (TP-M 12)	154
300113 (P 50/2)	127	300610 (EVP2-S)	133	400605 (6457-19L)	149	400961 (TP-M 16)	154
300120 (P 6/3)	127	300611 (EVP2-SK s krytom)	133	400606 (6457-20)	149	400962 (TP-M 20)	154
300121 (P 10/3)	127	300620 (EVP-K)	133	400607 (6457-21)	149	400963 (TP-M 25)	154
300122 (P 25/3)	127	400010 (6455-11P/2)	140	400608 (6457-22)	149	400964 (TP-M 32)	154
300123 (P 50/3)	127	400011 (6455-11P/5)	140	400609 (6457-23)	149	400965 (TP-M 40)	154
300124 (P 120/3)	127	400012 (6455-11P/7)	140	400620 (6457-14)	149	400966 (TP-M 50)	154
300130 (P 6/5)	127	400013 (6455-11P/2/BM)	140	400621 (6457-14 S)	149	400967 (TP-M 63)	154
300131 (P 10/5)	127	400014 (6455-12P/2)	140	400622 (6457-24)	149	400980 (TZ-M 20)	154
300132 (P 25/5)	127	400015 (6455-12P/5)	140	400623 (6457-24 S)	149	400981 (TZ-M 25)	154
300140 (6035-03)	128	400016 (6455-12P/7)	140	400700 (Pp/t-1)	150	400982 (TZ-M 32)	154
300141 (6035-13)	128	400017 (6455-26P/2)	140	400701 (Pp/t-3)	150	400983 (TZ-M 40)	154
300142 (6035-23)	128	400018 (6455-26P/5)	140	400702 (Pp/t-2)	150	401000 (SP 2,5)	154
300143 (6035-33)	128	400019 (6455-26P/2E)	140	400703 (Pp/t-4)	150	401001 (SP 6)	154
300150 (6035-12)	128	400020 (6455-27P/2)	140	400704 (Pp/t-5)	150	401010 (SP 35)	154
300151 (6035-22)	128	400021 (6455-27P/5)	140	400705 (Pp/t-7)	150	401050 (6700-00/P)	155
300152 (6035-32)	128	400022 (6455-11 5.P/2 ACIDUR 3)	140	400706 (Pp/t-6)	150	401051 (6701-00/P)	155
300160 (Z5)	127	400023 (6455-11 5.P/5 ACIDUR 3)	140	400707 (Pp/t-8)	150	401060 (6100-04)	155
300170 (6035-01 K)	128	400024 (6455-11 5.P/7 ACIDUR 3)	140	400708 (Pp/t-9)	150	401061 (6100-15)	155
300190 (RSD 88)	128	400025 (6455-12 5.P/2 ACIDUR 3)	140	400720 (PZO)	150	401070 (6100-44)	155
300200 (TS 35/10/0)	129	400026 (6455-12 5.P/5 ACIDUR 3)	140	400800 (TV-Pg 7)	151	401080 (H 6)	156
300201 (TS 35/160/2)	129	400027 (6455-12 5.P/7 ACIDUR 3)	140	400801 (TV-Pg 9)	151	401081 (H 8)	156
300202 (TS 35/20/0)	129	400030 (6455-30)	140	400802 (TV-Pg 11)	151	401082 (H 10)	156
300203 (TS 35/210/2)	129	400031 (6455-31)	140	400803 (TV-Pg 13)	151	401083 (H 12)	156
300204 (TS 35/250/2)	129	400032 (6455-32)	140	400804 (TV-Pg 16)	151	401100 (VPN 2-100)	156
300205 (TS 35/30/0)	129	400040 (6456-13)	141	400805 (TV-Pg 16-16)	151	401101 (VPN 2-135)	156
300206 (TS 35/40/0)	129	400100 (6400-201/3)	141	400806 (TV-Pg 21)	151	401102 (VPN 2-160)	156
300207 (TS 35/50/0)	129	400101 (6400-211/3)	141	400807 (TV-Pg 21-20)	151	401103 (VPN 2-200)	156
300208 (TS 35/60/0)	129	400102 (6400-221/3)	141	400808 (TV-Pg 29)	151	401104 (VPN 4-140)	156
300209 (TS 35/70/0)	129	400110 (6400 H-201/3)	141	400809 (TV-Pg 36)	151	401105 (VPN 4-200)	156
300210 (TS 35/80/0)	129	400120 (6400-41)	141	400820 (TVM-Pg 7)	151	401106 (VPN 4-280)	156
300211 (TS 35/90/0)	129	400130 (6400-301)	142	400821 (TVM-Pg 9)	151	401107 (VPN 4-360)	156
300212 (TS 35/100/0)	129	400140 (6400-10)	142	400822 (TVM-Pg 11)	151	401108 (VPN 5-200)	156
300213 (TS 35/110/0)	129	400150 (V 081)	142	400823 (TVM-Pg 13)	151	401109 (VPN 5-250)	156
300214 (TS 35/120/0)	129	400151 (V 082)	142	400824 (TVM-Pg 16)	151	401110 (VPN 5-280)	156
300222 (TSP 35-SZP 35H7/1)	129	400152 (V 120)	142	400825 (TVM-Pg 16-16)	151	401111 (VPN 5-360)	156
300229 (TSP 35-SZP35H7/2)	129	400200 (KUP 68H-201/3 LP SK)	143	400826 (TVM-Pg 21)	151	401112 (VPN 5-380)	156
300232 (TSP 35-SZP35H15/1)	129	400201 (KUP 68H-221/3 LP SK)	143	400827 (TVM-Pg 21-20)	151	401113 (VPN 5-430)	156
300239 (TSP 35-SZP35H15/2)	129	400211 (KUP 68 LP/SK)	143	400828 (TVM-Pg 29)	151	401114 (VPN 8-200)	156
300250 (7/Z)	129	400212 (KUP 68 LP/2 SK)	143	400829 (TVM-Pg 36)	151	401115 (VPN 8-280)	156
300251 (7/N)	129	400213 (KUP 68 LP/3 SK)	143	400840 (Pg 7)	152	401116 (VPN 8-360)	156
300252 (7/C)	129	400214 (KUP 68 LP/4 SK)	144	400841 (Pg 9)	152	401117 (VPN 8-450)	156
300253 (7/Y)	129	400215 (KUP 68 LA/5)	144	400842 (Pg 11)	152	401118 (VPN 8-540)	156
300254 (12/Z)	129	400250 (6303-13 P1/S)	144	400843 (Pg 13)	152	401119 (VPN 8-710)	156
300255 (12/N)	129	400251 (6303-15 P/S)	144	400844 (Pg 16)	152	401121 (VPN 9-780)	156
300256 (12/C)	129	400253 (6304-15/S)	144	400845 (Pg 21)	152	401122 (VPN 13-500)	156
300257 (12/Y)	129	400300 (6410-10)	145	400846 (Pg 29)	152	401123 (VPN 13-730)	156
300258 (15/Z)	129	400301 (6410-20)	145	400847 (Pg 36)	152	401125 (VPN 13-1000)	156
300259 (15/N)	129	400302 (6410-30)	145	400848 (Pg 42)	152	401200 (VPB 2-100)	156
300260 (15/C)	129	400310 (S-Box 036)	146	400849 (Pg 48)	152	401201 (VPB 2-135)	156
300261 (15/Y)	129	400350 (S-Box 106)	146	400860 (UM 7/02)	152	401202 (VPB 2-160)	156
300300 (NS 154/100)	130	400351 (S-Box 206)	146	400861 (UM 9/02)	152	401203 (VPB 2-200)	156

401204 (VPB 4-140)	156	500067 (K300/16)	165	500666 (7610-06/06/100)	166	501116 (7610-12/M 8FR)	170
401205 (VPB 4-200)	156	500068 (K400/12)	165	500667 (7610-06/08/100)	166	501117 (7610-12/M 10FR)	170
401206 (VPB 4-280)	156	500069 (K400/16)	165	500668 (7610-06/10/100)	166	501118 (7610-12/M 12FR)	170
401207 (VPB 4-360)	156	500070 (K400/20)	165	500669 (7610-06/12/100)	166	501120 (7610-13/M 3FB)	170
401208 (VPB 5-200)	156	500080 (LK 6/50)	165	500700 (7610-07/06/100)	166	501121 (7610-13/M 3,5FB)	170
401209 (VPB 5-250)	156	500081 (LK 10/150)	165	500701 (7610-07/08/100)	166	501122 (7610-13/M 4FB)	170
401210 (VPB 5-280)	156	500090 (LKS-1,5)	165	500702 (7610-07/10/100)	166	501123 (7610-13/M 5FB)	170
401211 (VPB 5-360)	156	500091 (LKS-2,5)	165	500703 (7610-07/12/100)	166	501124 (7610-13/M 6FB)	170
401212 (VPB 5-380)	156	500092 (LKS-4)	165	500704 (7610-08/08/50)	166	501125 (7610-13/M 8FB)	170
401213 (VPB 5-430)	156	500093 (LKS-6)	165	500705 (7610-08/10/50)	166	501126 (7610-13/M 10FB)	170
401214 (VPB 8-200)	156	500094 (LKS-10)	165	500706 (7610-08/12/50)	166	501127 (7610-13/M 12FB)	170
401215 (VPB 8-280)	156	500095 (LKS-16)	165	500707 (7610-09/08/25)	166	501128 (7610-15/M 3FG)	170
401216 (VPB 8-360)	156	500096 (LKS-25)	165	500708 (7610-09/10/25)	166	501129 (7610-15/M 3,5FG)	170
401217 (VPB 8-450)	156	500097 (LKS-35)	165	500709 (7610-09/12/25)	166	501130 (7610-15/M 4FG)	170
401218 (VPB 8-540)	156	500098 (LKS-50)	165	500710 (7610-10/10/25)	166	501131 (7610-15/M 5FG)	170
401219 (VPB 8-710)	156	500099 (LKS-70)	165	500711 (7610-10/12/25)	166	501132 (7610-15/M 6FG)	170
401221 (VPB 9-780)	156	500100 (LKS-95)	165	500712 (7610-11/10/10)	166	501133 (7610-15/M 8FG)	170
401222 (VPB 13-500)	156	500101 (LKS-120)	165	500713 (7610-11/12/10)	166	501134 (7610-15/M 10FG)	170
401223 (VPB 13-730)	156	500102 (LKS-150)	165	500714 (7610-12/10/10)	166	501135 (7610-15/M 12FG)	170
401225 (VPB 13-1000)	156	500103 (LKS-185)	165	500715 (7610-12/12/10)	166	501150 (DI 0,14/6)	170
401300 (USN 19-19)	157	500104 (LKS-240)	165	500716 (7610-12/16/10)	166	501151 (DI 0,25/6)	170
401301 (USN 29-29)	157	500105 (LKS-300)	165	500717 (7610-13/12/10)	166	501152 (DI 0,25/8)	170
401302 (USB 19-19)	157	500106 (LKS-400)	165	500718 (7610-13/16/10)	166	501153 (DI 0,34/6)	170
401303 (USB 29-29)	157	500120 (7580-07)	167	500719 (7610-14/12/5)	166	501154 (DI 0,34/8)	170
401310 (UZB 9-43)	157	500121 (7580-08)	167	500720 (7610-14/16/5)	166	501155 (DI 0,5/6)	170
500000 (K1,5/4)	164	500122 (7580-09)	167	500800 (7400-01/100)	167	501156 (DI 0,5/8)	170
500001 (K1,5/5)	164	500123 (7585-10)	167	500801 (7400-03/100)	167	501157 (DI 0,5/10)	170
500002 (K1,5/6)	164	500124 (7585-11)	167	500802 (7400-05/100)	167	501158 (DI 0,75/6)	170
500004 (K2,5/4)	164	500125 (7585-12)	167	500803 (7400-06/100)	167	501159 (DI 0,75/8)	170
500005 (K2,5/5)	164	500126 (7585-13)	167	500804 (7400-07/100)	167	501160 (DI 0,75/10)	170
500006 (K2,5/6)	164	500127 (7585-14)	167	501000 (LKS-1,5 IZR)	168	501161 (DI 0,75/12)	170
500007 (K2,5/8)	164	500141 (7373-03/100)	167	501001 (LKS-2,5 IZB)	168	501162 (DI 1/6)	170
500008 (K4/4)	164	500142 (7373-05/100)	167	501002 (LKS-6 IZG)	168	501163 (DI 1/8)	170
500009 (K4/5)	164	500143 (7373-07/100)	167	501010 (7305-12FR)	168	501164 (DI 1/10)	170
500010 (K4/6)	164	500144 (7373-08/100)	167	501011 (7308-12FR)	168	501165 (DI 1/12)	170
500011 (K4/8)	164	500145 (7373-09/100)	167	501012 (7405-12FR)	168	501166 (DI 1,5/8)	170
500012 (K6/5)	164	500146 (7373-12/50)	167	501013 (7408-12FR)	168	501167 (DI 1,5/10)	170
500013 (K6/6)	164	500147 (7373-14/25)	167	501014 (7608-12FR)	168	501168 (DI 1,5/12)	170
500014 (K6/8)	164	500148 (7373-16/25)	167	501015 (7305-13FB)	168	501169 (DI 1,5/18)	170
500015 (K6/10)	164	500149 (7373-18/25)	167	501016 (7308-13FB)	168	501170 (DI 2,5/8)	170
500016 (K10/5)	164	500162 (7100-01/100)	172	501017 (7405-13FB)	168	501171 (DI 2,5/12)	170
500017 (K10/6)	164	500163 (7100-11/100)	172	501018 (7408-13FB)	168	501172 (DI 2,5/18)	170
500018 (K10/8)	164	500164 (7101-01/100)	172	501019 (7608-13FB)	168	501173 (DI 4/10)	170
500019 (K10/10)	164	500165 (7101-11/100)	172	501020 (7608-15FG)	168	501174 (DI 4/12)	170
500020 (K16/5)	164	500168 (7102-01/100)	172	501021 (7912-15FG)	168	501175 (DI 4/18)	170
500021 (K16/6)	164	500169 (7102-11/100)	172	501030 (7305P-12FR)	168	501176 (DI 6/12)	171
500022 (K16/8)	164	500170 (7102-03/100)	172	501031 (7308P-12FR)	168	501177 (DI 6/18)	171
500023 (K16/10)	164	500171 (7102-13/100)	172	501032 (7405P-12FR)	168	501178 (DI 10/12)	171
500024 (K16/12)	164	500172 (7102-05/100)	172	501033 (7408P-12FR)	168	501179 (DI 10/18)	171
500025 (K25/6)	164	500173 (7102-15/100)	172	501034 (7608P-12FR)	168	501180 (DI 16/12)	171
500026 (K25/8)	164	500190 (7212-03/100)	172	501035 (7405P-13FB)	168	501181 (DI 16/18)	171
500027 (K25/10)	164	500191 (7212-13/100)	172	501036 (7408P-13FB)	168	501182 (DI 25/16)	171
500028 (K25/12)	164	500200 (7132-03/100)	173	501037 (7608P-13FB)	168	501183 (DI 25/22)	171
500029 (K35/6)	164	500224 (7202-00/4/100)	173	501038 (7608P-15FG)	168	501184 (DI 35/16)	171
500030 (K35/8)	164	500226 (7202-00/5/100)	173	501050 (7305-12MR)	169	501185 (DI 35/25)	171
500031 (K35/10)	164	500240 (7242-00/5/1)	173	501051 (7308-12MR)	169	501186 (DI 50/20)	171
500032 (K35/12)	164	500260 (7122-01/100)	174	501052 (7405-12MR)	169	501187 (DI 50/25)	171
500033 (K50/6)	164	500261 (7122-11/100)	174	501053 (7408-12MR)	169	501188 (DI 70/20)	171
500034 (K50/8)	164	500262 (7122-03/100)	174	501054 (7608-12MR)	169	501189 (DI 95/25)	171
500035 (K50/10)	164	500263 (7122-13/100)	174	501055 (7405-13MB)	169	501190 (DI 120/27)	171
500036 (K50/12)	164	500280 (7232-01/100)	174	501056 (7408-13MB)	169	501191 (DI 150/32)	171
500037 (K50/16)	164	500281 (7232-11/100)	174	501057 (7608-13MB)	169	501210 (DID 0,5/8)	171
500038 (K70/6)	164	500282 (7232-03/100)	174	501058 (7608-15MG)	169	501211 (DID 0,5/10)	171
500039 (K70/8)	164	500283 (7232-13/100)	174	501070 (7608-12FMR)	169	501212 (DID 0,75/8)	171
500040 (K70/10)	164	500300 (7912-20)	172	501071 (7608-13FMB)	169	501213 (DID 0,75/10)	171
500041 (K70/12)	164	500440 (7942-10)	174	501072 (7608-15FMG)	169	501214 (DID 1/8)	171
500042 (K70/16)	164	500441 (7962-10)	174	501080 (7612-12/U 3FR)	169	501215 (DID 1/10)	171
500043 (K95/8)	164	500442 (7982-10)	174	501081 (7612-12/U 3,5FR)	169	501216 (DID 1,5/8)	171
500044 (K95/10)	164	500460 (7042-10)	174	501082 (7612-12/U 4FR)	169	501217 (DID 1,5/12)	171
500045 (K95/12)	164	500461 (7062-10)	174	501083 (7612-12/U 5FR)	169	501218 (DID 2,5/10)	171
500046 (K95/16)	164	500462 (7082-10)	174	501084 (7612-12/U 6FR)	169	501219 (DID 2,5/13)	171
500048 (K120/8)	164	500480 (7922-00)	175	501085 (7612-12/U 8FR)	169	501220 (DID 4/12)	171
500049 (K120/10)	164	500500 (7022-00)	175	501086 (7612-12/U 10FR)	169	501221 (DID 4/18)	171
500050 (K120/12)	164	500650 (7610-01/03/100)	166	501088 (7612-13/U 3FB)	169	501222 (DID 6/14)	171
500051 (K120/16)	164	500651 (7610-01/3,5/100)	166	501089 (7612-13/U 3,5FB)	169	501223 (DID 6/18)	171
500052 (K150/8)	165	500652 (7610-01/04/100)	166	501090 (7612-13/U 4FB)	169	501224 (DID 10/14)	171
500053 (K150/10)	165	500653 (7610-01/05/100)	166	501091 (7612-13/U 5FB)	169	501225 (DID 16/16)	171
500054 (K150/12)	165	500654 (7610-03/03/100)	166	501092 (7612-13/U 6FB)	169	501240 (7400-P8 FR)	171
500055 (K150/16)	165	500655 (7610-03/3,5/100)	166	501093 (7612-13/U 8FB)	169	501241 (7400-P10 FR)	171
500056 (K185/10)	165	500656 (7610-03/04/100)	166	501096 (7612-15/U 3,5FG)	169	501242 (7400-P12 FR)	171
500057 (K185/12)	165	500657 (7610-03/05/100)	166	501097 (7612-15/U 4FG)	169	501243 (7400-P8 FB)	171
500058 (K185/16)	165	500658 (7610-03/06/100)	166	501098 (7612-15/U 5FG)	169	501244 (7400-P10 FB)	171
500059 (K185/20)	165	500659 (7610-03/08/100)	166	501099 (7612-15/U 6FG)	169	501245 (7400-P12 FB)	171
500060 (K240/10)	165	500660 (7610-05/04/100)	166	501100 (7612-15/U 8FG)	169	501248 (7400-P14 FB)	171
500061 (K240/12)	165	500661 (7610-05/05/100)	166	501111 (7610-12/M 3FR)	170		
500062 (K240/14)	165	500662 (7610-05/06/100)	166	501112 (7610-12/M 3,5FR)	170		
500063 (K240/16)	165	500663 (7610-05/08/100)	166	501113 (7610-12/M 4FR)	170		
500064 (K240/20)	165	500664 (7610-05/10/100)	166	501114 (7610-12/M 5FR)	170		
500066 (K300/12)	165	500665 (7610-06/05/100)	166	501115 (7610-12/M 6FR)	170		



SEZ DK a. s., M. R. Stefanika 1831/46
026 19 Dolny Kubin, Slovakia
Tel.: +421 43 5809 226; +421 908 948 580
e-mail: sales@sez.sk

WWW.SEZ.SK

12/2023

CONNECTING
ENERGY

